





TABLE OF CONTENTS

SECTION I	INTRODUCTION		
	Contents	1-1	
	Checklists	1-2	
	Citizen's Band Transceiver	1-3	
	Hot Weather Operation	1-3	
	Cold Weather Operation	1-4	
	Campground Courtesies	1-4	
	Insurance	1-4	
	Safety Considerations	1-5	
	Vehicle Loading	1-6	
	Economical Driving	1-7	
	Engine Operating Hints	1-7	
	Lubrication and Maintenance	1-8	
	Traveling in Your Motorhome	1-8	
SECTION II	OPERATION		
	Introduction	2-1	
	Instrumentation Panels	2-3	
	Dashboard Instrumentation	2-3	
	Steering Column Controls	2-6	
	Overhead Instrumentation	2-7	
	CB Transceiver Unit	2-9	
	Radar Detector	2-13	
	The (Musical) Horn	2-14	
	Right-Hand Monitor Panel	2-15	
	Floor Controls	2-16	
	Diesel Engine Operation	2-16	
	Trailer Hitch Capacity	2-16	
	Transmission Start-Up		
	Inspection	2-17	
	Driving Tips	2-18	
	General Information —		
	Caterpillar Diesel Engines	2-18	
SECTION III	LIVING AREA FACILITIES		
	Introduction	3-1	
	Galley Facilities	3-2	
	Refrigerator	3-2	
	Gas Range and Oven	3-4	
	Galley Sink	3-5	
	Food Center	3-5	
	Bathroom	3-5	
	Roof Vents and Exhaust Fans	3-6	
	Heating Systems	3-6	
	Air Conditioning	3-8	
	Systems Monitoring and		
	Control Panels	3-9	
	The Clock and The Monitor	3-9	
	Switching and Monitor		
	Panel	3-10	
	Carbon Monoxide Detector	3-10	
	Power Line Monitors	3-10	
	Lifeguard One	3-10	
	Electronic Door Chime	3-11	
	Digital In/Out Thermometer	3-12	
	Fire Extinguisher	3-12	
	TV Antenna and Rotator	3-13	
SECTION IV	ELECTRICAL SYSTEMS		
	Introduction	4-1	
	12-Volt Dc Supply System	4-1	
	Motorhome 12-Volt Circuits	4-1	
	Battery Charger	4-2	
	DC Supply Monitors	4-3	
	AC Supply System	4-3	
	Power Line Monitors	4-4	
	Ac Circuit Breaker Panels	4-4	
	Generator Operation	4-4	
	Ac Shoreline Operation		
	(Commercial Power)	4-5	
	Safeline Alarm	4-6	
SECTION V	WATER DISTRIBUTION SYSTEM		
	Introduction	5-1	
	Potable Water Distribution		
	System	5-3	
	Hot Water Heater	5-4	
	Plumbing and Drainage System	5-4	
	Draining the Holding Tanks	5-4	
	Tank Level Detectors	5-5	
	Winterizing	5-5	
	Draining the Fresh Water		
	System	5-5	
	Preparing Drainage System		
	for Storage	5-5	
	Battery Storage in		
	Freezing Weather	5-6	
	General Storage Notes	5-6	
SECTION VI	LPG SYSTEM		
	Introduction	6-1	
	LPG Tank	6-1	
	Fuel Requirements	6-1	
	Lifeguard One	6-2	
	LPG Regulator	6-2	
SECTION VII	AIR BRAKE SYSTEMS		
	Introduction	7-1	



TABLE OF CONTENTS (continued)

SECTION VII AIR BRAKE SYSTEMS (cont.)	
Operation	7-1
SECTION VIII OWNER MAINTENANCE DATA	
Introduction	8-1
Specifications and Data	8-1
Changing Tires	8-2
Batteries	8-3
Fluid Level Checks	8-4
Water Pump Maintenance	8-5
Windshield Washers	8-9
Generator	8-9
Battery	8-9
Air Cleaner Maintenance	8-9
Crankcase Breather Cap.	8-10
Lubrication	8-10
Cooling System	8-11
Fuel and Carburetor	
	Adjustments 8-12
	Ignition System 8-13
	Belt Tension Adjustment 8-14
	Governor Adjustment 8-14
	Generator Troubleshooting 8-15
	Engine Troubleshooting 8-17
	Storage Procedures 8-17
	Suburban Dyna-Trail Furnace 8-18
	Air Conditioning System 8-21
	Dometic Refrigerator 8-21
	Aqua-Magic Toilet 8-23
	SECTION IX GENERAL INFORMATION
	SECTION X DIAGRAMS
	SECTION XI OPTIONAL EQUIPMENT

LIST OF ILLUSTRATIONS

Figure 1-1.	Identification Plate	1-6	Figure 3-10.	Hallway Lighted Vent/ Exhaust Fan	3-6
Figure 1-2.	Typical Identification Plate	1-7	Figure 3-11.	Exhaust Fan Control Panel	3-6
Figure 2-1.	Driver's Compartment Instrumentation Panels	2-1	Figure 3-12.	Heater Thermostat	3-6
Figure 2-2.	Dashboard Instrumentation	2-2	Figure 3-13.	Deleted	
Figure 2-3.	Digital Clock	2-5	Figure 3-14.	The Clock and The Monitor	3-9
Figure 2-4.	Steering Column Controls	2-6	Figure 3-15.	Switching and Monitor Panel	3-10
Figure 2-5.	Speed Control	2-6	Figure 3-16.	Carbon Monoxide Detector and Power Line Monitors	3-10
Figure 2-7.	FM/AM Stereo Tuner	2-7	Figure 3-17.	Lifeguard One	3-11
Figure 2-8.	8-Track Tape Player	2-8	Figure 3-18.	Electronic Door Chime Controls	3-11
Figure 2-9.	Cassette Tape Player	2-8	Figure 3-19.	Digital In/Out Thermometer	3-12
Figure 2-10.	Stereo Power Booster	2-9	Figure 3-20.	Antenna Rotator	3-13
Figure 2-11.	CB Transceiver Unit	2-9	Figure 4-1.	Circuit Breaker Panels (12V)	4-1
Figure 2-12.	Radar Detector	2-13	Figure 4-2.	Fuse Panel	4-2
Figure 2-13.	The Horn	2-14	Figure 4-3.	Location of Battery Chargers	4-3
Figure 2-14.	Right-Hand Monitor Panel	2-15	Figure 4-4.	Ac Power Selector Switch	4-4
Figure 2-15.	Transmission Shift Selector	2-17	Figure 4-5.	Load Center Circuit Breakers	4-4
Figure 3-1.	Vacuum Cleaner System	3-1	Figure 4-6.	Over-Current Circuit Breakers	4-4
Figure 3-2.	Dinette Area	3-1	Figure 4-7.	Generator Compartment Extended	4-5
Figure 3-3.	Galley Facilities	3-2	Figure 4-8.	Shoreline Hookups	4-6
Figure 3-4.	Refrigerator Operating Controls	3-2	Figure 5-1.	Location of Water Fill and Commercial Water Hookups	5-1
Figure 3-5.	Gas Range and Oven	3-4	Figure 5-2.	Under-Sink Plumbing	5-2
Figure 3-6.	Food Center	3-5			
Figure 3-7.	Stall Shower	3-5			
Figure 3-8.	Toilet	3-6			
Figure 3-9.	Bathroom Vent/Exhaust Fan	3-6			



LIST OF ILLUSTRATIONS (continued)

Figure 5-3.	Front Right Side Compartment 5-2	Figure 8-7A.	Air Cleaner 8-10
Figure 5-4.	Filter Cartridge 5-3	Figure 8-8.	Oil Dipstick 8-10
Figure 5-5.	Location of Holding Tanks Drain Valves 5-4	Figure 8-9.	Oil Pressure Adjustment 8-11
Figure 6-1.	Location of LPG Tank and Controls 6-1	Figure 8-10.	Generator Cooling System 8-11
Figure 8-1.	Generator Gas Tank Access Panel 8-2	Figure 8-11.	Idle Fuel Adjustments 8-12
Figure 8-2.	Locating Tire Jack 8-2	Figure 8-12.	Choke Adjustment 8-13
Figure 8-3.	Oil Dipstick Location, Engine Hood Removed 8-4	Figure 8-13.	Breaker Point Adjustment 8-13
Figure 8-4.	Power Steering Reservoir 8-5	Figure 8-14.	Belt Tension Adjustment 8-14
Figure 8-5.	Transmission Dipstick Location 8-5	Figure 8-15.	Governor Adjustment 8-14
Figure 8-6.	Exploded View of Pump 8-7	Figure 8-16.	Controller Fuse Location 8-16
Figure 8-7.	Generator Component Locations 8-8	Figure 10-1.	12V Dc Supply System, Overall Wiring Diagram 10-3
		Figure 10-2.	120/240V Ac Supply System, Overall Wiring Diagram 10-5
		Figure 10-3.	Potable Water System 10-7
		Figure 10-4.	Plumbing Drainage System 10-9
		Figure 10-5.	Heater Piping Diagram 10-11
		Figure 10-6.	LP Gas Piping Diagram 10-13

LIST OF TABLES

Table 4-1.	Circuit Breakers for Chassis Wiring (12V) 4-2	Table 8-4.	12-Volt Lighting and Equipment, Current Usage 8-1
Table 4-2.	Circuit Breakers for Body Wiring (12V) 4-2	Table 8-5.	Water Pump Troubleshooting Guide 8-6
Table 4-3.	Circuit Breakers (12V) 4-2	Table 8-6.	Water Pump Parts List 8-7
Table 4-4.	Battery Compartment Fuses (12V) 4-2	Table 8-7.	Generator Troubleshooting Guide 8-15
Table 4-5.	Electrical Ratings for Motorhome Appliances 4-6	Table 8-8.	Engine Troubleshooting 8-17
Table 8-1.	Engine Capacities and Specifications 8-1	Table 8-9.	Common Generator Parts 8-17
Table 8-2.	Generator Capacities and Specifications 8-1	Table 8-10.	Suburban Dyna-Trail Furnace Troubleshooting Guide 8-18
Table 8-3.	Motorhome Capacities and Specifications 8-1	Table 8-11.	Dometic Refrigerator Troubleshooting Guide 8-22
		Table 8-12.	Aqua-Magic Toilet Troubleshooting Guide 8-23



SECTION I

INTRODUCTION

CONTENTS

This section of your Owner's Manual contains general hints and recommendations for using your motorhome. Checklists and suggestions are offered which cover just about every phase of motorhome travel.

The remaining sections of this manual, Sections II through XI, describe in detail the operation and use of the individual items and systems which comprise your motorhome. The following paragraphs summarize the contents of these sections:

SECTION II OPERATION — Covers driver's instrumentation, operating controls, gauges and indicators. General data on operation of coach vehicular systems are also covered in this section.

SECTION III LIVING AREA FACILITIES — Covers operation of heating and air conditioning systems, use of accessories and appliances and related general coach facilities data.

SECTION IV ELECTRICAL SYSTEMS — This section describes operation of coach electrical systems, ac/dc operation and generator switching are also covered.

SECTION V WATER DISTRIBUTION SYSTEMS — Covers internal supply and distribution, plumbing, city water hookups, tank fill and sanitizing, holding tank dumping and operation of hot water supply system.

SECTION VI LPG SYSTEM — This section describes LPG internal supply and distribution, tank filling procedures, system component locations, and precautions to observe regarding LPG handling.

SECTION VII AIR BRAKE SYSTEMS — This section covers operation of the service brakes and spring brake systems, fail/safe features and general brakes system operation.

SECTION VIII OWNER MAINTENANCE

DATA — Includes information on maintenance procedures which may be within the scope of the owner. Coverage is provided for preventive maintenance schedules, specifications and system capacities, cold weather operation, storage and winterizing. Interior/exterior appearance care and emergency maintenance procedures are also described.

SECTION IX GENERAL INFORMATION — A list of major components, including model numbers, name and address of manufacturer.

SECTION X DIAGRAMS — Contains wiring, schematic, piping and general-purpose diagrams to assist in troubleshooting and understanding how these systems function.

SECTION XI OPTIONAL EQUIPMENT — This section provides you with information on optional equipment and features used in your motorhome.

We hope that this manual will answer any questions that may arise about the use, operation and maintenance of your motorhome. Any suggestions or recommendations that you might have for including or expanding on material of interest will be carefully considered for incorporation in periodic supplements. We are always interested in providing our coach owners with the most current and comprehensive information about our product.

Your satisfaction is our assurance that we are fulfilling our responsibilities to our owners.



CHECKLISTS

A little preliminary planning will go a long way to help make your trips successful and enjoyable. As an aid to planning your travels, review the following checklists. If there are any additional items that you should be reminded of, add them where you see fit. These lists are only recommendations based on the experience and suggestions of sources well-versed in motor-coach expertise. You will eventually find that a short "walk-around" the coach, outside and inside, will be adequate and comprehensive enough to ensure that you're ready for travel.

BEFORE YOU LEAVE:

- Store valuables and important papers in a safe place.
- Arrange care for your pets.
- Cover all food to keep out mice and insects.
- Store oil, gasoline, matches and other inflammables properly; get rid of newspapers, magazines and oily rags.
- Connect timers to several inside lamps and outside lights; keep some shades open for a lived-in look.
- Discontinue newspaper, milk and other deliveries; store trash cans and outside equipment.
- If weather permits, shut down hot water and heating systems; close main water supply.
- Ask the Post Office to hold your mail.
- Have your lawn, garden and house plants cared for.
- Arrange with the Telephone Company for discontinued or "Vacation Service".
- Lock all windows and doors securely.
- Leave your key with your neighbor; let him know your basic itinerary.
- Notify police.

CHECKOUT YOUR COACH -- OUTSIDE:

- Disconnect and stow:
 - a. Electrical hook-up cord.
 - b. Sewer hose hook-up (flush out).
 - c. Water hook-up hose.
- Check all exterior lights for damage.
- Check wheel lug nuts for tightness.
- Check tires for correct pressure.

- Check that all external compartments and filler openings are properly closed and/or locked.
- Check that items stored on exterior of coach are secured. (Be sure that these items present no clearance problems.)

NOTE

If the trip you are planning will take the coach well past suggested maintenance intervals listed in Section VIII, it may be advisable to perform these procedures before leaving. This may avoid unscheduled stops or interruptions during your trip.

- Check that there are no obstacles to avoid above or under the coach. Be sure that there is sufficient clearance front and rear.

CHECKOUT YOUR COACH -- INSIDE:

- Turn off water pump switches.
- Close windows and vents.
- Check that cabinet doors and drawers are closed.
- Check that refrigerator door is fastened.
- Check that no heavy items are stored in overhead cabinets.
- Store large items in base cabinets.
- Check that counter tops, range top, table tops and shelves are clear of unsecured items.
- Turn off interior lights; check that step is in closed position.
- Secure and lock the entrance door.
- Adjust exterior and interior mirrors.

CHECK YOUR AUTOMOTIVE SYSTEMS:

- Check that fluid levels are normal (oil, power steering, engine coolant, battery electrolyte, windshield washers, transmission, etc.).
- Check generator oil level, coolant level, battery condition.
- Check operation of turn signals, emergency flasher, stoplights and backup lights.
- Check that headlight high- and low-beams operate.
- Check horn operation.
- Check fuel gauge.



- Start engine and check gauges for signs of trouble.
- Check operation of foot brakes, emergency brake. (See that brake pressure builds up and steadies at about 90 to 105 psi.)
- Check tire pressure.

AND, BEFORE DRIVING AWAY:

- Check operation of appliances and special equipment.
- Check that fire extinguisher is fully charged.
- Check operation of interior and exterior lighting.
- Start generator and check 120v ac system and wall outlets.
- Adjust driver's seat so that all controls are within easy reach.
- Make sure that seat is locked in position. Do not adjust driver's seat swivel or fore-aft mechanism while vehicle is moving or seat could move unexpectedly, causing a loss of control.
- Check that front passenger's seat is locked in position.
- Fasten seat belts. Belts should be placed as low as possible around the hips. This places the load of the body on the strong hip bone structure instead of around the soft abdominal area and prevents sliding out in case of an accident.
- Check that warning lights are lit when the ignition key is turned to ON or START position.

SOME ITEMS YOU MIGHT WANT TO TAKE ALONG ON YOUR TRIP

NOTE

You may find that many items taken were not needed and that some items that were needed were overlooked during planning of your last trip. Make note of these items to prevent duplicating the same errors.

- Spare water filter element.
- Adequate supply of prescription medicines.
- Prescription sunglasses or reading glasses.
- Camera equipment and film supply.
- Heating pads, ice bags, etc.
- Stationery, envelopes, stamps.

- Telephone number list.
- Reading material.
- Special pet supplies.
- Extra toilet chemical and toilet articles.
- Spare belts for engine-operated equipment.
- Spare parts for generator: suggested spares include sparkplugs, oil filter, fuel pump, air filter, solenoid. Four quarts of approved generator oil.
- A professional-type double-action tire pressure gauge.
- Under the heading of "Emergency Equipment", it is advisable to consider outfitting your coach with these items:
 - a. First-aid kit
 - b. Emergency highway flares
 - c. Flashlight or lantern (with extra batteries)
 - d. Tool kit
 - e. Replacement lamp assortment
 - f. Replacement fuse assortment
 - g. A trouble light with a long cord

AND SOME OTHER THOUGHTS TO CONSIDER

- Automobile insurance to cover you and your family.
- Avoid cash. Use traveler's checks and credit cards wherever possible.
- Confirm reservations well in advance of arrival.
- Make a clothing check list for everyone.

CITIZEN'S BAND TRANSCEIVER

You might also bear in mind that your coach is equipped with a CB unit (Citizen's Band receiver-transmitter). In the event of an emergency situation which requires outside assistance, remember to call for help on Channel 9. This channel is restricted to emergency use only and it is monitored 24 hours per day! Be a "Good Buddy" — don't hesitate to use your CB if you see someone else in need of assistance. Remember that you will need a Canadian license to operate your CB radio during your travels in Canada.

HOT WEATHER OPERATION

Wherever possible, choose a shaded parking site so that the coach will be cooler during the hottest part of the day. The full-length side awning will



be especially useful in lowering inside temperature. Roof-mounted air conditioners are indispensable in hot climates. Keep in mind that their proper operation depends on adequate line voltage. Low voltage causes motors to run hotter and reduces compressor motor life. Supply voltage in some campgrounds may not be as high as necessary, especially when there are heavy loads on the lines from other air conditioners. Check the wall-mounted voltmeter when in doubt.

COLD WEATHER OPERATION

LPG appliances, furnace, and gas refrigerator are designed with sealed combustion areas. This is for your protection to prevent danger from carbon monoxide or depletion of oxygen. Your motorhome is equipped with Lifeguard One, a highly accurate and sensitive propane gas detector. Heed alarm indications!

If frost or condensation accumulate in closets or cabinets during long periods of cold weather operation, leave the doors to these areas slightly ajar to provide air circulation. Be sure that roof vents are open when using oven or burners.

CAMPGROUND COURTESY

Don't forget the "Golden Rule". Being considerate of your neighbors will help make friends. A few of the "Do's" and "Don'ts" are:

- Good housekeeping — put all litter in the proper receptacles and leave your site neat and clean.
- Don't allow your water or sewer hook-ups to leak.
- Respect your neighbor's desire to retire at an early hour. Avoid loud noises and bright lights after dark.
- Drive slowly through camp areas at any hour for the safety of pedestrians.

INSURANCE

As with your automobile, it is important that you have adequate protection with insurance coverages for personal liability, theft, collision, overturn, property damage, etc.

CANADIAN AND MEXICAN INSURANCE

Insurance for travel in Canada can usually be covered by your present U.S. policy for the recreational vehicle, often at no extra cost. Consult your individual insurance company for procedures and be sure of your coverage before entry.

For travel in Mexico (at the present time) there are no U.S. insurance companies that can provide recognized Mexican coverage, with the exception of that required for travel through a narrow strip of Mexican territory in and around ports of entry and the U.S./Mexican border.

Mexican insurance is controlled, and rates are set, by the Mexican government. There are several reliable companies handling Mexican insurance, with similar rates for the necessary coverages. The principal differences between them are the "fringe benefits", received in the form of informational travelogs and other helpful information, such as dining places considered acceptable for sanitary conditions, fuel stations, and so on.

Some insurance services include detailed route maps with "where to stay" recommendations and "things to see" mile-by-mile (or kilometer-by-kilometer post). While the rates set by Mexico may seem quite expensive at first glance, you usually end up not spending quite as much as expected because you can usually arrange to hold your state-side policy in abeyance during the same period you are in Mexico, thus not having to pay unnecessarily for double coverage. In addition, you may be able to obtain substantial refunds on the Mexican collision insurance after your return to the U.S. Be sure to obtain a certification from the park operator at each location in Mexico to certify the dates that your coach was parked there. If your coach is parked for most of the time, instead of constantly traveling, your refund may be a major portion of the original cost. This feature is referred to as the "in-storage" credit. (It is a good idea to always check with your insurance company before taking a trip to find out whether applicable insurance rules and regulations have changed. Keep up to date on your coverage.)

Carry insurance papers at all times!



SAFETY CONSIDERATIONS

USING LP GAS

Check for leaks at the connections on the LP gas system soon after purchase and initial filling of LP tank; continued periodic checks of the system are recommended. Even though the manufacturer and dealer have already made tests for leakage, this check is advisable because of the vibrations encountered during travel. The coach construction provides access to all gas line connections. Apply a soapy water solution to the outside of gas piping connections to find gas leakage (bubbles). Usually, tightening of connections will close leaks. (Be sure to first shut off the gas supply!) If not, ask your authorized dealer service to make the needed repairs.

Liquified Petroleum Gas (LPG) is heavier than air. Leaking gas tends to flow to low places, such as does water. It will sometimes pocket in a low area. LP gas can usually be detected by an identifiable odor characteristic to onions or garlic.

CAUTION

Never light a match or allow any open flame in the presence of leaking gas!

Be sure that the main LP gas supply valve is closed during refueling to prevent accidental ignition of gasoline fumes by appliance pilot lights.

Do not exceed the rated liquid capacity of the LPG tank. Overfilling may cause LPG to flow through the regulator causing it to freeze and create excessive gas line pressure. It is a good practice to watch while the tank is being filled to insure that this safety precaution will not be violated.

ELECTRICAL SYSTEMS

Your coach has been engineered and checked for your complete electrical system safety. Circuit breakers and fuses are installed to protect electrical circuits from overloading. Before making modifications or additions to the electrical system, consult your dealer for assistance in obtaining a safe and secure installation.

Do not "jump" circuit protectors!

BUILT-IN POWER CORD ADAPTER

Approved power supply cords are supplied with the coach for hookup to external power sources. One cord is intended for hookup to 110-volt ac 30 ampere power, and a 20-ampere adapter is also supplied with this cord. A second cord is supplied for hookup to 220 volts ac, single-phase, 50 ampere power. Note that each cord has a ground pin which provide proper electrical system grounding. The ground pin is your personal protection from electrical shock hazards. Do not use any adapter, cheater, or extension cord that will break the continuity of the grounding circuit. NEVER remove the grounding pin for convenience of being able to make a connection to a non-grounded receptacle!

NEVER operate your coach with a "hot skin"! If you can feel even a slight "tingling" shock from touching the coach body while standing outside on the ground, immediately disconnect the electrical hookup until the trouble is located. This fault is usually caused by a break in the grounding circuit, which should be continuous from the coach skin or frame to the distribution panel board to the third (ground) pin on the power supply cord, and from there to the park receptacle and earth ground. Your motorhome is equipped with dual polarity-protector alarm panels, located on the galley wall. These panels are for your protection in ensuring against improper grounding or reversed hookups, both of which will be indicated by an alarm condition. Heed alarm signals.

A power cord adapter is also supplied which will allow connection of two 30-ampere 120-volt lines (from separate external circuits) to the shore-line plug in the rear of your coach. This will allow use of all motorhome appliances without overload of the supply lines.

EMERGENCY STOPS

Always carry road flares and/or reflective triangular highway warning markers for emergency warning display. Pull off the roadway as far as possible when changing flats or for other emergency situations. Turn on your hazard warning flashers when parked alongside a roadway, even if only for a short while. Have your coach occupants leave the vehicle and stand clear of the area when parked on the edge of a highway.



When loading your motorhome, store heavy gear first, keeping it on or as close to the floor as possible. Heavy items should be stored centrally so as to distribute the weight more or less evenly between the front and the rear axles. Store only light objects on high shelves. Distribute weight to obtain even side-to-side balance of the loaded unit. Secure loose items to prevent weight shifts that could adversely affect the balance and roadability of the vehicle.

To find the actual weight, with the motorhome fully loaded, drive to a scale and read the weight on the front and on the rear wheels, separately, to determine axle loading. The load on each

axle should not exceed its GAWR. If weight ratings are exceeded, move or remove items to bring all weights below the ratings.

Additional data plates located underneath the hood table provide information useful for identifying your coach if you are planning on ordering parts. A typical identification plate, figure 1-2, provides the following information:

1. Body Serial Number
2. Chassis Serial Number
3. Model, Year
4. Model Number of Axle (if axle parts are to be ordered)

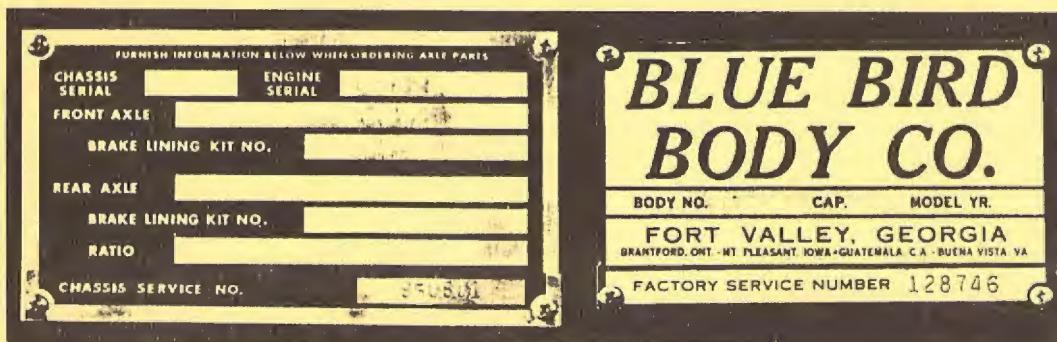

Figure 1-2. Typical Identification Plate

ECONOMICAL DRIVING

How you drive, where you drive and when you drive — these factors all have an effect on determining how many miles you can get from a gallon of fuel. The careful attention you give your vehicle, as far as maintenance and repairs are concerned, will also contribute to fuel economy.

ENGINE OPERATING HINTS

It is recommended that you use Number 2 diesel fuel for your diesel engine. In the event that emergency assistance is required, contact Caterpillar Tractor Company, Engine Division, Peoria, Illinois, via this emergency number:

(800) 447-4986

[In Illinois, call: (800) 322-2806.]

“JACKRABBIT” STARTS

Fuel can be conserved — and engine and tire life prolonged — by avoiding unnecessarily rapid acceleration away from lights and stop signs.

STOP-AND-START DRIVING

Frequent stops and starts during a trip diminish miles per gallon. Plan even short shopping trips to take advantage of through-streets to avoid the traffic lights. Pace your driving like the professional drivers to avoid unnecessary stops.

EXCESSIVE IDLING

An idling engine also consumes fuel. If you are faced with more than a few minutes wait, and you are not in traffic, it may be advisable to shut off the engine and re-start later on.



LUBRICATION AND MAINTENANCE

A properly lubricated vehicle means less friction between moving parts. Consult the maintenance schedules in Section VIII for proper lubricants, lubrication intervals and general coach maintenance scheduling.

AIR CLEANER

The mixture of fuel and air which powers the engine is taken into the system through the air cleaner. Replace the air cleaner at required intervals to maintain peak engine efficiency.

EXCESS WEIGHT

Fuel economy is also related directly to the amount of work accomplished by the engine. Heavier loads require more power. Keep excess weight to a minimum.

TIRE INFLATION

Under-inflation causes needless tire wear and promotes excess fuel consumption. Check tire pressures on a regular basis. (Michelin recommends that front tires be inflated to 105 pounds; rear tires should be inflated to 75 pounds.)

TRAVELING IN YOUR MOTORHOME

OVERNIGHT STOPS

There are many modern recreational vehicle parks with good facilities, including State, County and Federal Parks, where electrical, water and sewer connections are readily available. Directories are published which describe these parks in detail and list available services and hookups.

On overnight or short weekend trips, your motorhome has more than adequate holding tanks and water supply capacity in the event that campgrounds or parking sites are not equipped with these facilities.

On longer trips, where sewer connections and utility hookups are unavailable, it will be necessary to stop from time to time to dispose of holding tank wastes and replenish the water supply. Many gas stations (chain and individually-owned) have in-

stalled sanitary dumping stations for just this purpose.

When stopping for the night, park the coach in a location that is relatively level and where the ground is firm. This will ensure your comfort as well as the leveling of your refrigerator (for most efficient operation).

EXTENDED STAYS

Making a long trip is not very different from making a weekend excursion since everything you need is right at hand and you are home wherever you travel. When packing for an extended trip, try to avoid taking non-essential items.

When planning to stay in the same location for several days, weeks, or even months, be sure to maintain the motorhome level. To be sure of this, check the attitude (level) with a small bubble level set on the refrigerator freezer shelf, or on the work counter. If corrections are necessary, level the coach from side to side first. This can be done most easily by driving the coach up a small ramp consisting of 2" x 6" boards, about 4 feet long, tapered at both ends. Do not place tires in a hole to level the coach!

Hook up to the water supply by attaching the water hose to the commercial water supply inlet.

Plug the electrical cable into the shoreline receptacle. Be sure to observe all grounding and connection precautions!

Attach sewage and waste hookup into the disposal facility.

WINTER TRAVELING

Certain precautions should be taken when traveling in your motorhome during the cold winter months. Keep these suggestions in mind:

- Provide heat in the coach at all times.
- Have a plentiful supply of LPG.
- If your stay is longer than overnight, and you do not use the generator, try to have a shoreline hooked up to outside ac power.
- Minimize your use of electricity if 120v ac is unavailable.



- Leave cabinet doors and wardrobe doors slightly open at night to allow for proper air circulation.

Remember that low temperatures in combination with high winds will cause an equivalent chill temperature much below that indicated by

your thermometer. For instance, with an outside temperature of zero degrees, and a wind velocity of 10 miles per hour, the equivalent chill temperature would be -20 degrees F!

There is no substitute for common sense when traveling in cold weather.



SECTION II OPERATION

INTRODUCTION

This section provides information on the operation and function of the controls, indicators, and gauges used in connection with the coach automotive systems. Figure 2-1 illustrates the driver's compartment, highlighting the instrumentation and panels covered in succeeding paragraphs.

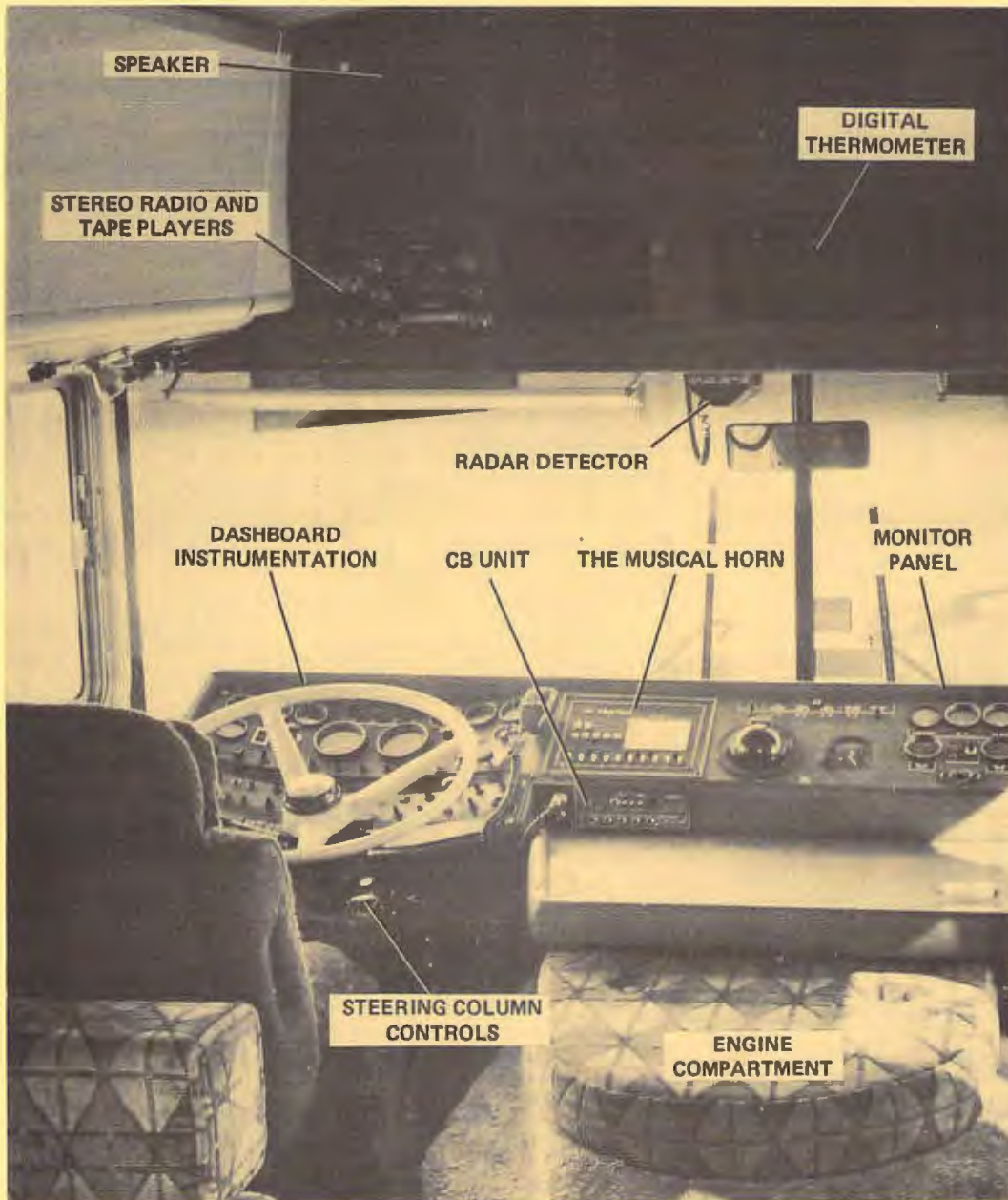
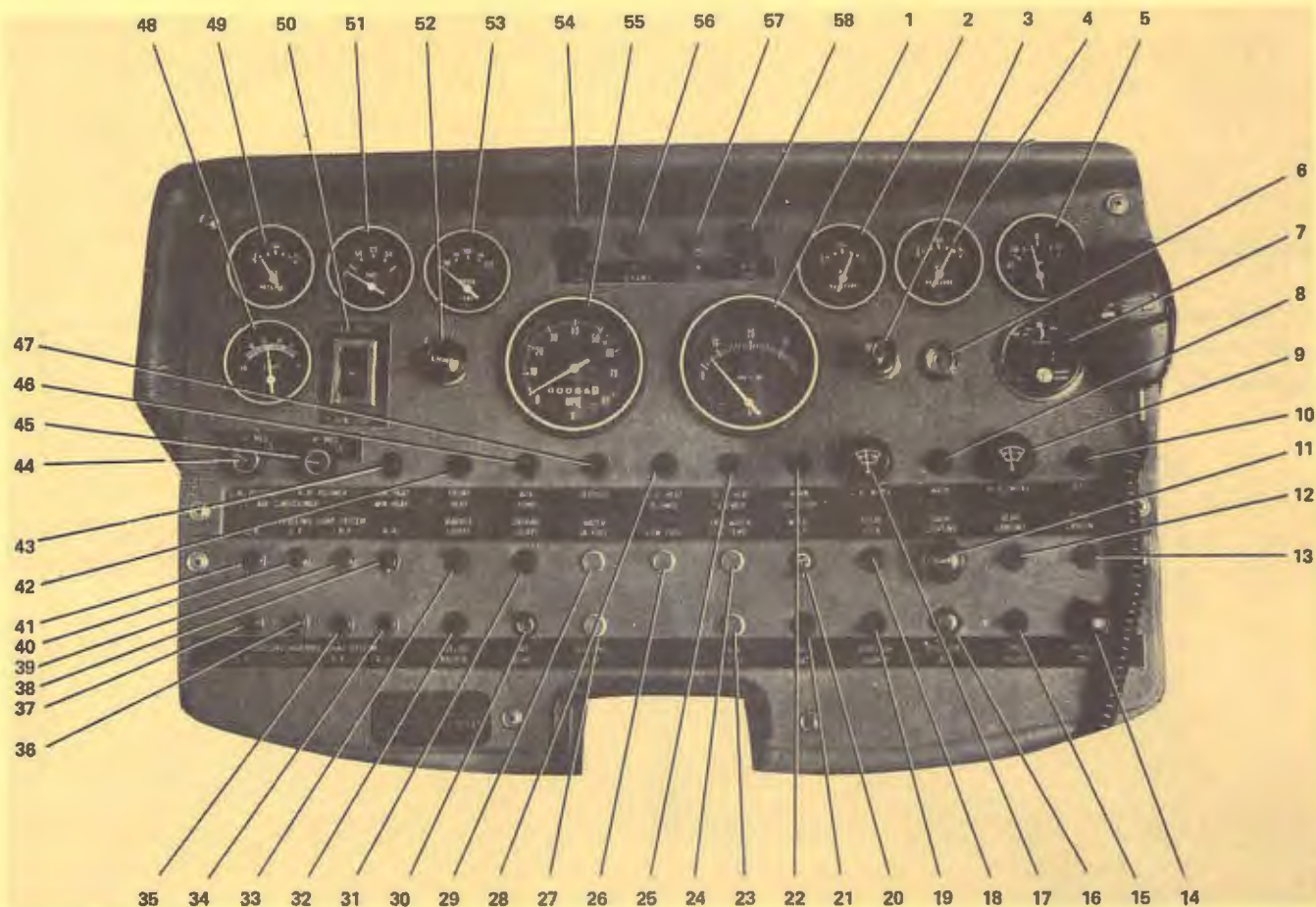

Figure 2-1. Driver's Compartment Instrumentation Panels



- | | |
|------------------------------------|--|
| 1. RPM Gauge | 30. DAY/NIGHT Switch |
| 2. AIR PRESSURE Gauge | 31. DRIVING LIGHTS Switch |
| 3. LIGHTER | 32. LEVELING MASTER Switch |
| 4. AIR PRESSURE Gauge | 33. MARKER LIGHTS Switch |
| 5. AMMETER | 34. R.R. LEVELING WARNING Indicator |
| 6. IGNITION | 35. R.F. LEVELING WARNING Indicator |
| 7. Digital Clock | 36. L.F. LEVELING WARNING Indicator |
| 8. WASH Switch | 37. L.R. LEVELING WARNING Indicator |
| 9. R.H. WIPER Control | 38. R.R. LEVELING LIGHT SYSTEM Indicator |
| 10. A/T Switch | 39. R.F. LEVELING LIGHT SYSTEM Indicator |
| 11. DASH LIGHTING Control | 40. L.F. LEVELING LIGHT SYSTEM Indicator |
| 12. REAR LANDING LIGHTS Switch | 41. L.R. LEVELING LIGHT SYSTEM Indicator |
| 13. FRONT LANDING LIGHTS Switch | 42. FRONT HEAT Switch |
| 14. SPOTLIGHT SPEED Control | 43. SUM. HEAT/WIN. HEAT Switch |
| 15. SPOT/FLOOD Switch | 44. A.C. L.H. BLOWER Control |
| 16. SPOTLIGHT AIM Control | 45. A.C. R.H. BLOWER Control |
| 17. L.H. WIPER Control | 46. AUX. PUMP Switch |
| 18. DOOR LOCK Switch | 47. DEFROST Switch |
| 19. BURGLAR ALARM Switch | 48. VOLTMETER |
| 20. WHEEL TILT Switch | 49. OIL PRESSURE Gauge |
| 21. AUX. BATT. Switch | 50. GEN. START/STOP Switch |
| 22. HORN SELECTOR Switch | 51. FUEL Gauge |
| 23. AUX. STEP. Indicator | 52. LIGHT Control |
| 24. ENG. WATER/OIL/TEMP. Indicator | 53. TEMPERATURE Gauge |
| 25. R.H. HEATER BLOWER Switch | 54. L.H. DIR. Indicator |
| 26. LOW FUEL Indicator | 55. SPEEDOMETER/ODOMETER |
| 27. LEVELING PILOT Indicator | 56. HI BEAM Indicator |
| 28. L.H. HEAT BLOWER Switch | 57. LOW AIR Indicator |
| 29. WATER IN FUEL Indicator | 58. R.H. DIR. Indicator |

Figure 2-2. Dashboard Instrumentation



INSTRUMENTATION PANELS

Within easy reach of the driver are located the dashboard instrumentation panels, for monitoring engine performance; upper left panel, which contains the AM/FM radio, stereo cassette and 8-track tape players, power amplifier and controls (and closed-circuit TV, if this option is included); the bulkhead panels, containing the stereo speakers; upper right panel, with digital thermometer; center monitor panel, containing The Horn, CB unit, compass, altimeter, switching and generator monitors.

DASHBOARD INSTRUMENTATION

The following controls and indicators are shown in figure 2-2.

OIL PRESSURE GAUGE — Indicates the pressure of the oil, not the amount of oil in the reservoir. This gauge will normally read on the high side during cruising speeds; and drop towards the low side when engine is idling.

CAUTION

No oil pressure, or low oil pressure readings when engine is operating are trouble indications. Check oil level. **DO NOT OPERATE THE ENGINE UNDER THESE CONDITIONS.**

FUEL GAUGE — Indicates amount of diesel fuel remaining in the fuel tank (maximum capacity is 150 gallons). This gauge reads only when the ignition switch is in ON or ACCESSORY position. The fuel gauge used on 31-foot and 33-foot units is a dual-purpose monitor: when the fuel tank selector switch is operated, it can also read the level of gas (30 gallons maximum) remaining in the generator fuel tank.

TEMPERATURE GAUGE — Registers the engine coolant temperature from 100 to 240 degrees.

NOTE

If temperature gauge consistently indicates high engine temperatures (100 degrees higher than outside temperature) the engine is overheating and should be stopped before damage occurs. Allow engine to cool before checking radiator and/or reservoir coolant level.

TURN SIGNALS — Located above the speedometer and tachometer, the left or right green turn signal lights blink in conjunction with the outside directional lights when the turn signal lever is set to the corresponding position. Both turn signals blink in unison when the emergency flasher switch on the steering column is pressed inward (ON).

HI-BEAM INDICATOR — Lights when headlights dimmer floor switch is pressed for high beam operation and headlights switch is ON.

LOW AIR WARNING LIGHT AND BUZZER — Warning indicator is lit whenever system air pressure is below 60 psi; a buzzer located behind the panel will also sound for low-pressure conditions.

CAUTION

IT IS NOT SAFE TO DRIVE THE UNIT IF LOW AIR PRESSURE WARNING LIGHT IS ON AND AIR PRESSURE GAUGES DO NOT INDICATE WITHIN SAFE LIMITS (100 psi to 120 psi).

AIR BRAKE PRESSURE GAUGES — The dual air service brakes pressure systems are engine-operated and supply independent brake system air pressure for front and rear service brake systems, parking brake and air-operated accessories. Under normal operation, each air pressure gauge reading will build up to approximately 100 to 120 psi shortly after the engine is turned on. The parking brake cannot be released until air pressure readings are at least 60 psi.

BATTERY AMPS METER — Center-reading ammeter graduated from -100 amperes to +100 amperes shows whether battery is charging or discharging, while engine is operating. Normally, the pointer reads center-scale, or slightly to the right (charge). This meter will indicate battery current drawn when the ignition is off. However, it will not indicate battery charging current supplied from the battery chargers when the engine is off and ac power is available. This charging current is indicated by the ammeter located behind the stepwell access panel.

Note that constant excessive charging or discharging can be an indication of a charging system problem. Check battery electrolyte level; check battery terminals and cables for looseness or corrosion.



BATTERY VOLTS METER — Expanded-scale voltmeter graduated from 10 to 16 volts shows condition of battery charge when ignition is ON. Normal battery voltage varies from about 12 to 13 volts; with engine running, and no battery loads, the battery charging voltage read on the meter is about 14.7 volts. Battery voltage readings of less than 10.5 or more than 15 are usually a symptom of a battery or electrical system failure.

GENERATOR ON-OFF SWITCH — Provides local control for generator operation. Press this center-off momentary switch ON and hold until generator starts, as indicated by the switch indicator illuminating. If generator does not start within 15 to 20 seconds, release switch, wait 30 seconds, then try again. To shut down the generator, press to OFF and hold until light extinguishes.

NOTE

When starting a diesel-type of generator during extreme cold weather, press the switch in to OFF position for about a minute. This activates the pre-heater in the fuel supply line to aid in easier starting.

HEADLIGHT SWITCH — Three-position control operates dash and exterior lights in much the same manner as a standard automotive lights control. Extend switch out to first detent position to turn on panel and parking lights; turn control clockwise to decrease panel lighting; turn counterclockwise to increase panel lighting; pull out to last detent position to turn on headlights. Press floor dimmer switch to select high- or low-beams.

SPEEDOMETER/ODOMETER — Indicates speed and accumulated mileage.

TACHOMETER — Indicates the true diesel engine RPM (revolutions per minute) X 100 on a 0 to 4,000 RPM scale. Use this gauge as an overall engine performance indicator.

NOTE

Diesel engines normally idle at about 500 to 700 RPM. During normal running, maintain 2,000 RPM for optimum performance. Normal diesel operating range is 2,000 to 2,800 RPM.

CIGARETTE LIGHTER — Depress to heat element, which pops out to normal position when hot.

IGNITION SWITCH — Standard automotive-type ignition switch, with four positions for accessory and ignition control. In OFF position (center) the ignition and accessory positions are disabled and the key can be inserted or removed. In ON position (right) the battery is connected to the ignition circuits and the key can be advanced to the START position to start the engine. When released from START, the key returns to ON position. ACCESSORY position allows operation of accessories as in ON position, without activating ignition circuits.

NOTE

The ignition switch will start the engine only when the transmission lever is in N (neutral) position.

AIR CONDITIONER L.H. AND R.H. BLOWER CONTROLS — Dual three-speed blower controls set the speed of the automotive air conditioner blowers for the front of the coach. The AIR CONDITIONER thermostat, located below the steering column, controls the temperature of the cooling air by cycling the air conditioner compressor.

SUM. HEAT/WIN. HEAT SWITCH — Operates solenoid valves in engine coolant line to divert coolant through water heater and chassis heaters when set to WIN. HEAT position. In SUM. HEAT position, coolant flow is through hot water supply heater coil.

FRONT HEAT SWITCH — Operates solenoid valves which provide heat to front heater cores.

AUXILIARY PUMP SWITCH — Controls an auxiliary water pump (under left rear corner of coach) that circulates water through the heat exchanger, hot water heater and under-seat heaters.

DEFROST SWITCH — Dual-speed switch controls operation of the dual blower motors which direct defroster air to the front windows. Note that the automotive air conditioner blowers may also be used for defrosting when thermostat is in OFF position.



HEAT BLOWER SWITCHES — L.H. and R.H. switches control the operation of heater blower motors at their respective locations. (Three heaters at the rear of the coach have individual controls.)

HORN SELECTOR SWITCH — Allows selection of air, electrical or musical horns, on coaches so equipped.

WIPER AND WASHER CONTROLS — Dual-speed independent wiper arm controls (L.H. WIPER and R.H. WIPER) are provided on the right side of the dash. The WASHER switch, located between these controls, operates a pump which directs a stream of water to each windshield surface.

A/T SWITCH — Activates anti-theft circuits.

MARKER LIGHTS SWITCH — Operate this control to turn on the clearance lamps located on the top, sides and ends of the coach.

WATER IN FUEL INDICATOR — Lights when excessive water condensate accumulates in diesel fuel filter/preheater (located in LPG compartment, figure 6-1).

LOW FUEL INDICATOR — Lights when diesel fuel tank supply is below 1/4 full.

ENGINE, WATER, OIL, TEMPERATURE INDICATORS — Lights and buzzer sounds when associated monitors detect an alarm condition in any of the engine operating characteristics.

WHEEL TILT SWITCH — Controls air-operated steering wheel tilt mechanism to allow positioning of steering wheel to one of three detent positions. Flip lever back to lock wheel into position.

CAUTION

Always make sure that lever is in the fully-locked position in whichever detent setting is used. Do not change tilt setting while unit is in motion.

DOOR LOCK SWITCH — Locks and unlocks coach entry door.

DASH LIGHTING CONTROL — Adjusts intensity of panel marking lighting from off to full brightness.

DAY/NIGHT SWITCH — Two-position switch allows half or full-brightness for coach interior lights.

AUXILIARY STEP INDICATOR — Lights when air-operated entry door step is extended.

AUX BATTERY SWITCH — Operating this momentary switch connects the generator battery in parallel with the automotive batteries to provide a greater current source for engine or generator hard-starting situations. Release the switch after the engine starts.

BURGLAR ALARM SWITCH — Activates coach burglar alarm system.

DIGITAL CLOCK — The digital clock is shown in figure 2-3. Set the clock timing and alarm functions as follows:



Figure 2-3. Digital Clock

Set Calendar — Turn rotary function switch to CAL/SET position. Move toggle switch to Hrs position to set months; or move to Min position to set days. After setting, return function switch to CLK/CAL position for proper time and date display.



NOTE

Set calendar before 11:59 AM for proper date-changing.

Set Time — For initial setting, cycle clock through 24 hours. Turn function switch to CLK/SET. Move toggle to Hrs position and hold until proper hour and time of day (AM or PM) is displayed. Move toggle to Min position to set minutes. After setting, turn function switch to either CLK/CAL position for proper time/date display; or to ALARM position for time-only display and alarm function.

Set Alarm — Turn function switch to ALM SET position. Move toggle to Hrs position and hold until desired hour AND time of day (AM or PM) is displayed for the alarm to operate. Move toggle to Min position to set minutes. After setting, to activate alarm, turn function switch to ALARM position.

Alarm Shutoff — Turn function switch from ALARM position to CLK/CAL position.

NOTE

The alarm can be set again for the same time, the following day, after one minute past the time that the alarm went off.

STEERING COLUMN CONTROLS

The steering column contains the horn button, turn signal lever/speed control, emergency flasher, throttle control, auto air conditioner temperature control and the parking brake.



Figure 2-4. Steering Column Controls

HORN — Operate the horn by pressing in on the center section of the wheel. Select air or electric horn with HORN SELECTOR switch on dash.

TURN SIGNAL LEVER — Move lever upward to signal a right turn; move downward to signal a left turn.

SPEED CONTROL — The speed control, figure 2-5, is installed as a part of the turn signal lever. Before operating the speed control to lock in the coach speed, the unit must be traveling at least 35 to 40 miles per hour. Slide the switch left to ON position and press in the button at the end of the lever to set in the speed to the automatic controls. The accelerator may be used to increase the speed while traveling, but the speed cannot be decreased unless the brake pedal is operated, or the speed control is set to OFF. In the event that you desire to resume the speed at which you were traveling before the brake was operated, slide the switch to the left to the momentary RESUME position and the vehicle will automatically resume the original speed. Be sure to set speed control to OFF when not in use.



Figure 2-5. Speed Control

EMERGENCY FLASHER SWITCH — The emergency flasher is located on the right side of the steering column. Pull the switch outward to turn on the flashing warning lights; push the switch inward to shut the flashers off. Note that the dashboard directional signals flash in unison.

THROTTLE CONTROL — Adjust engine idle speed by pulling this control outward (increase), or pushing inward (decrease).

A.C. TEMP CONTROL — Operates in conjunction with the AIR CONDITIONER L.H. and R.H. blower controls to set auto air cooling temperature.



PARKING BRAKE CONTROL — Push in to release parking brake; pull outward to apply brake.

NOTE

Do not push in this control if pressure gauge indicates less than 60 psi.

VOLT MASTER SWITCH — Setting switch to OFF position turns off all 12-volt supplies except for the digital clock supply.

FRESH AIR CONTROLS — Graduated control in front of co-pilot's seat controls flow of air on that side of coach. A push-pull control, located beneath dash, to right of steering column, controls flow of fresh air to driver's side.

OVERHEAD INSTRUMENTATION

The upper panel, figure 2-6, located directly above the driver, contains the FM/AM stereo tuner, 8-track tape player, cassette player, stereo power booster amplifier and speaker balance controls.



Figure 2-6. Upper Panel

FM/AM STEREO TUNER — The FM/AM stereo tuner controls, figure 2-7, operates as follows:

POWER SWITCH (1) — Set to ON to apply power to unit and light up dial plate. To switch unit off, set switch to OFF position.

NOTE

When the 8-track or cassette player is operated, this unit will not function even if the POWER switch is ON. This occurs because the tape player then has priority. (Also, the dial plate lights even if POWER switch is off, providing tape player is operating.)

DX/LOC SELECTOR (2) — For FM reception: set Distant/Local selector to DX (distant) position for best reception in fringe or normal FM signal areas; or set to local (LOC) for best reception in areas where there are strong interfering FM signals.

BAND SELECTOR (3) — Selects desired radio band, either AM, FM AUTO, or FM. Set to AM position for AM reception and note that AM band indicator lights. Set to FM AUTO to receive FM STEREO or FM MONO programs and note that FM band indicator lights. Also, FM ST indicators will light when the program is broadcast in stereo. Set to FM position only when listening to FM MONO programs.

TUNING CONTROL (4) — Tunes in the desired radio station on the selected radio band.

NOTE

Set volume, balance and tone through the component system tape player and/or booster amplifier.

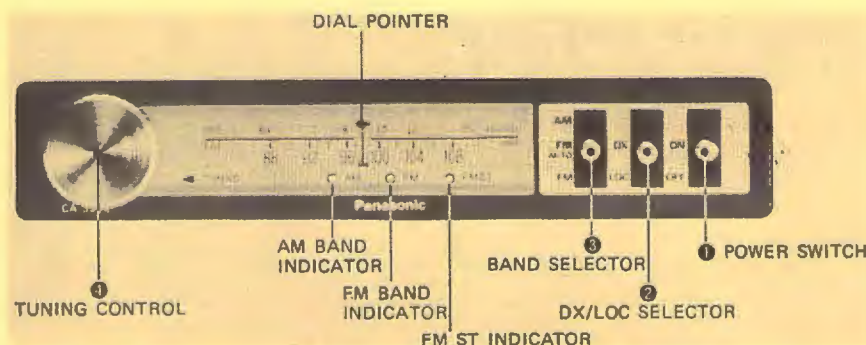

Figure 2-7. FM/AM Stereo Tuner



8-TRACK TAPE PLAYER — The 8-track tape player, figure 2-8, operates as follows:

TAPE SLOT (1) — To operate, insert tape cartridge into tape slot (label side up and open end first) until it clicks into position. The 8-track stereo tape will start to play each program in sequence automatically. The program indicators and the programs will automatically shift in the order 1-2-3-4-1, etc., until the tape player is turned off by removing the cartridge from the “locked” position. The tape cartridge should be removed from the slot when the player is not in use.

VOLUME CONTROL (2) — Clockwise rotation increases volume level.

BALANCE CONTROL (3) — Turn clockwise or counterclockwise for best stereo effect.

TONE CONTROLS (4) — Adjust LEFT and RIGHT tone controls for desired tonal quality.

PROGRAM SELECTOR (5) — Push in to advance each program manually, as desired; otherwise programs will change automatically. Each time this button is pressed, the next program will play. Do not push button in half-way or hold it down any longer than necessary to change the program.

PROGRAM INDICATOR (6) — Indicates which program is being played on the tape cartridge.

locked into position. Playback starts automatically when the cassette is in place. When the PROGRAM INDICATOR PRO-1 lights up, the top side of cassette is playing; when PRO-2 lights up, the bottom side is playing (reversed tape movement).

VOLUME CONTROL (2) — Clockwise rotation increases volume level.

BALANCE CONTROL (3) — Turn clockwise or counterclockwise for best stereo effect.

TONE CONTROLS (4) — Adjust LEFT and RIGHT tone controls for desired tonal quality.

PROGRAM SELECTOR (5) — Push to change the program manually, as desired. Otherwise, the program will change automatically. The PROGRAM INDICATOR indicates which program (side) is being played.

FF/REW/EJECT BUTTON (6) — To fast-forward the tape when PRO-1 is playing, push the ◀◀ button; to rewind, push the ▶▶ button. To fast-forward the tape when PRO-2 is playing, push the ▶▶ button; to rewind, push the ◀◀ button. To resume normal playback, simply release the button from the “locked-in” position. When the tape reaches the end during fast-forward or rewind operation, the tape will automatically reverse. The FF/REW button will return to its original position, playback will start on the other side, and the PROGRAM INDICATOR will change to show which program is being played. To eject the tape, push the middle part of this button fully in. The cassette then pops out for easy removal. Cassette tapes should be removed when player is not in use.



Figure 2-8. 8-Track Tape Player

CASSETTE TAPE PLAYER — The cassette tape player, figure 2-9, operates as follows:

CASSETTE SLOT (1) — Insert tape cassette firmly into tape slot (open end first) until it is

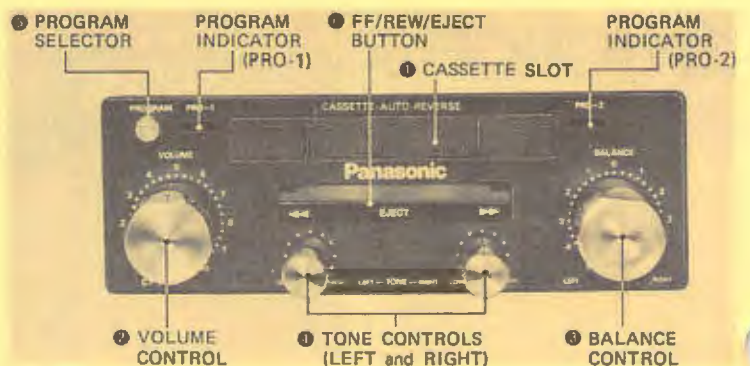

Figure 2-9. Cassette Tape Player



STEREO POWER BOOSTER — The stereo power booster, figure 2-10, is designed to operate in conjunction with the tuner or tape players. Operate this unit as follows:

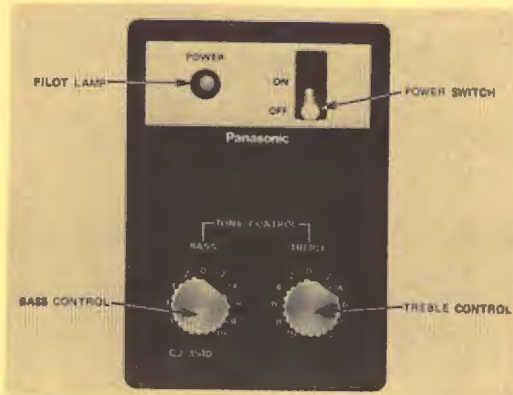

Figure 2-10. Stereo Power Booster

POWER SWITCH — Set to ON position to apply power to booster amplifier.

PILOT LAMP — Lights when POWER switch is ON.

BASS/TREBLE CONTROLS — Adjust for the desired tonal quality.

1. Set volume control of tape player to minimum position.
2. Set POWER switch ON, adjust tape player volume control to desired level.
3. Adjust bass and treble controls for desired tonal quality. (Set the bass and treble controls of tape player to NEUTRAL/center position.)
4. For best sound balance, adjust stereo balance controls.
5. After using, set POWER switch to OFF.

REMOTE SPEAKER CONTROLS — Adjust the volume of remote speakers.

CB TRANSCEIVER UNIT

Operation of the CB transceiver unit, figure 2-11, is regulated by the Federal Communications Commission (FCC). According to FCC rules, the transceiver is designed for licensed Class D operation on any of the 40 channels designated as

Citizen's Band frequencies and you are required to read and understand Part 95 of the FCC regulations prior to operating your unit. (A copy of this document is furnished with the CB.) Also, you **MUST** obtain a Class D station license before operating the CB. Transmitting without a license can result in penalties or fines. If you do not have a license, fill in the license application provided with the radio and mail it to the Federal Communications Commission. No oral or written examination is required.

CONTROLS AND INDICATORS — The functions of the controls and indicators shown in figure 2-11 are described in the following paragraphs:

PTT Switch (1) — The push-to-talk switch is used, when the CB is operating, to turn on the transmitter and allow microphone communication.

OFF/VOLUME Control (2) — In normal CB mode, turns transceiver on and controls speaker volume. In PA mode, controls volume level of received audio only. PA microphone audio is not affected by this control.

SQUELCH Control (3) — Allows operator to set receiver squelch so that only signals above that squelch level are heard. Weaker signals and background noise are eliminated.

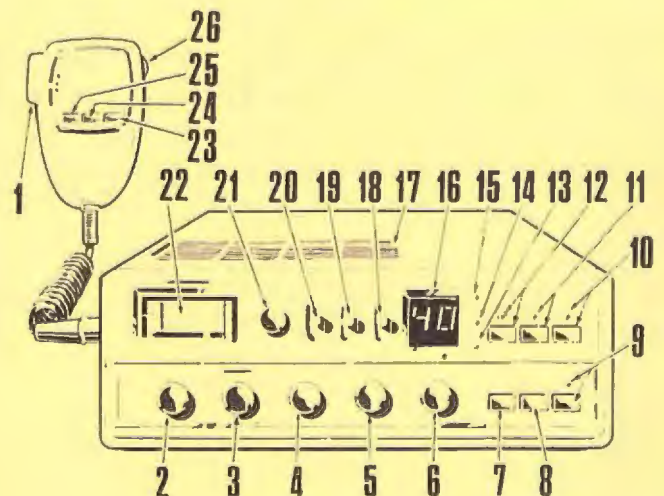

Figure 2-11. CB Transceiver Unit



RF GAIN Control (4) — Adjusts receiver sensitivity to cut down interference from weaker transmitters on a busy channel. When turned fully clockwise, the receiver is at maximum sensitivity. As the control is turned counterclockwise, the receiver becomes less sensitive to interference from weaker transmitters, resulting in clearer reception of the desired signal. The RF GAIN control is most effectively used in a crowded urban environment.

IF GAIN Control (5) — Adjusts radio noise without affecting receiver sensitivity. This control is especially useful while operating the unit in a rural area with an open squelch setting. Operated in the same manner as the RF GAIN control, the IF GAIN control trims away "radio hash" for quieter operation while maintaining the integrity of both receiver sensitivity and audio clarity. Generally, the volume must be turned up after activating this control. An increase in audio level will occur on close transmissions when this control is used.

ANL Control (6) — Reduces ignition noise and other man-made noise that may make the received signals unintelligible.

LOAD Button (7) — Places up to 10 channels in memory.

CLEAR Button (8) — Clears all channels previously loaded into memory.

MEMORY Button and Indicator (9) — Permits user to operate in the memory mode. If no channels are loaded into memory, channel 9 will be selected. If channels have been placed in memory, the unit will operate on only those channels and indicator light will be on.

BUSY Button and Indicator (10) — Allows the operator to search for a busy channel with automatic (SCAN) button. Indicator light will go on and remain on until OPEN button is pressed.

OPEN Button and Indicator (11) — Allows the operator to search for an open channel with the automatic (SCAN) button. Indicator light will go on and remain on until BUSY button is pressed.

SCAN Button and Indicator (12) — Activates circuit to automatically search the channels for either a busy or an open channel at a rate of 16 channels per second. Indicator light will be on while SCAN is in operation.

MOD (Modulation) Indicator (13) — Brightness indicates modulation strength.

RX (Receiver) Indicator (14) — Lights when receiver is on.

TX (Transmit) Indicator (15) — Lights when transmitter is on.

CHANNEL Indicator (16) — Displays channel selected.

INTERNAL SPEAKER (17) — In normal CB mode, reproduces received signals. (Internal speaker is bypassed if external speaker is used.) In PA mode, both the internal speaker and the speaker connected to the EXT SPKR jack are bypassed.

EXTD/OFF (Noise Blanker) Switch (18) — When in EXTD position, extends receiver range by reducing degrading effects of ignition noise and other electrical interference.

PA/CB (Public Address) Switch (19) — When in PA position, allows operator to use transceiver as a public address system through a roof-mounted speaker. With PTT switch depressed, microphone audio is routed to PA speaker. With PTT switch released, received audio is connected to the PA speaker and the loudness is controlled by the VOLUME control. Switch is kept in CB position for normal CB operation.

SWR-S/RF-CAL Switch (20) — In SWR position, the meter indicates SWR (Standing Wave Ratio). In S/RF position, the meter indicates the signal strength during reception and RF output level during transmission. CAL position is used to calibrate the meter for SWR measurements.

SWR/CAL Control (21) — Used to calibrate meter for SWR measurements.



S/RF/SWR Meter (22) — S/RF scale of meter indicates strength of received signals in “S” units. Relative RF output power of the transmitter is indicated by color: Red is normal output; Orange is low output. The SWR scale of the meter indicates the transmitting condition of the antenna system. The more efficient the antenna system is, the lower the reading will be. A reading of “1” is ideal.

DN Button (23) — Each time the DN button is pressed, the next lower channel (frequency) is locked in. (Ex: . . .3, 2, 1, 40, 39, 38, etc..)

REV Button (24) — Allows immediate return to original channel after finding an OPEN or BUSY channel with SCAN mode and takes radio out of scan memory.

UP Button (25) — Each time UP button is depressed, the next higher channel is selected and locked in. (Ex: . . .38, 39, 40, 1, 2, 3, etc..)

MIC GAIN Control (26) — Varies the modulation level for best possible transmission. In PA mode it allows user to vary PA microphone audio.

TURN-ON PROCEDURE

1. Turn OFF/VOLUME control (2) clockwise and observe that the following lights go on:
 - a. S/RF-SWR meter (22)
 - b. Channel indicator (16)
 - c. RX receive indicator (14)

Radio will not operate if microphone is not connected.

2. Adjust VOLUME control (2) for desired listening level. Be sure that PA/CB switch (19) is in CB position.

RECEIVE PROCEDURE

1. Select desired channel by pressing and releasing either UP button (25) or DN button (23) on the microphone until desired channel is locked in. (Note that it will be necessary to press the SCAN button if the SCAN indicator is on.) The S/RF meter (22) indicates the relative strength of the received signals.

2. Adjust RF gain, setting RF GAIN control (4), to a position that allows clear reception of the selected signals, while reducing unwanted

signals in strong signal areas.

3. Adjust IF gain, using the IF GAIN control (5), to provide a clear signal and reduce radio hash (noise).

4. Adjust ANL control (6) to reduce unwanted noise and maintain minimum audio distortion.

5. Set SQUELCH control (3) fully counter-clockwise, then advance control clockwise until background noise and undesired weak signals are eliminated.

EXTENDER FEATURE

1. Place EXTD switch (18) in EXTD position to reduce ignition noise from your own or adjacent vehicles or other types of electrical interference.
2. To turn extender circuit off, set switch OFF.

TRANSMITTING PROCEDURE

NOTE

Channel 9 has been designated by the FCC as an emergency channel. Use is primarily restricted to communication involving the immediate safety of life or protection of property; and, secondarily, to render assistance to a motorist. Many CB clubs, police, rescue units, hospitals and garages continuously monitor channel 9. Emergency calls made on any channel must be given priority!

Before transmitting, monitor the channels available to you to locate a clear channel.

1. Position microphone close to your mouth and at a slight angle.
2. Monitor the channel and, when clear, press and hold the PTT switch (1). The pointer on the S/RF meter (22) will deflect to the red area, indicating normal relative power output.
3. Contact the party you wish to speak with. Speak clearly and in a normal voice. To hear a reply, PTT switch (1) must be released.

INTERPRETING S/RF/SWR METER READINGS

— The transceiver is equipped with a multi-function meter. The S/RF scale of the meter indicates both relative transmitter output power and received signal strength. The SWR scale of the meter indicates antenna system condition.



(Since the SWR scale will be used only occasionally, leave SWR-S/RF-CAL switch in the S/RF position.)

The received signal strength scale is calibrated in S units on the left side of the scale, and in dB units above S9. The stronger the signal, the more that the meter deflects to the right. S1 is an extremely weak signal, S5 is an average signal, and S9 is an extremely strong signal. When using RF GAIN control (4), the previous readings apply when this control is fully clockwise. The meter will still give relative signal strength when RF GAIN is utilized and should be used while setting the RF GAIN control to the desired level. For example, you may be receiving the desired voice signals at an S9 level and, at the same time, receiving interfering signals at an S3 level. (Strength of the interfering weak signals can be read on the S scale during pauses in conversation.) To cut down the weak interfering signals, adjust receiver sensitivity with the RF GAIN control so that the strength of the voice signal drops from the S9 level to the S6 level. The voice signal should now read at an S6 level and the interfering weak S3 level signals will now be eliminated.

The transmitter relative power output scale is graduated by color, with red representing normal relative power output; and orange representing low relative power output.

For top performance and reliability, antenna SWR (Standing Wave Ratio) should be kept low. A low SWR assures that most of the RF output energy is radiated through the antenna, rather than being reflected back into the transmitter. A high SWR reduces communication range and, if transmitter operation is sustained, can shorten the equipment life.

To use the SWR scale, place SWR-S/RF-CAL switch (20) in CAL position. Press and hold PTT switch on microphone and turn SWR/CAL control (21) until meter pointer lines up with SWR calibration mark (arrow head) located at the upper right corner of the meter scale. Then place the SWR-S/RF-CAL switch in SWR position. Press and hold PTT switch and read SWR meter scale.

If the SWR reading is above "3", check antenna system, connectors and cable, for problems.

USING SQUELCH CONTROL — With the control fully open (counterclockwise), the receiver is so sensitive that even very weak signals from low power "Walkie-Talkies" and distant radio sets may be received. Many of these signals will be unintelligible due to the range and atmospheric conditions. As the SQUELCH control is advanced clockwise, stronger and stronger signals are required to "unsquelch" the receiver. In this way, the operator can establish the desired level that a signal must exceed before it is audible.

USING EXTENDER FEATURE — Reception in weak signal areas where interfering local noise is high can be improved by placing the EXTD switch (18) in EXTD position.

PUBLIC ADDRESS OPERATION — The PA feature also allows the operator to hear messages from outside the coach, as well as to make public address announcements over the PA speaker.

1. To hear received signals over the PA speaker instead of the internal speaker, place the PA/CB switch (19) in PA position. Adjust loudness with the VOLUME control (2).

2. To use the PA speaker for public address announcements, or as a one-way intercom, place PA/CB switch in PA position, press PTT switch (1) and speak into the microphone. Speaker loudness depends solely on voice level and microphone gain setting — the VOLUME control has no effect on the voice level. To silence received signals that may be heard when the PTT switch is released, turn the VOLUME control fully counterclockwise, but do not turn it off!

SCAN OPERATION — SCAN is used to automatically search channels, at a rate of 16 channels per second, to find either an OPEN (clear) channel or a BUSY channel.

1. Press either the OPEN (11) or the BUSY (10) button, then press the SCAN button. The associated indicator lights will go on.

2. Press either the DN button (23), to scan channels in descending order; or press the UP button (25) to scan channels in ascending order.

3. Use the SQUELCH control (3) to set desired level for channel selection. When a signal is above the set-squelch level, the channel will be seen as "busy" by the SCAN. When a signal is below the



set-squelch level, the channel will be seen as being "open" by the SCAN.

4. To change from SCAN, press SCAN button (12) or press REV button (24).

5. To scan only those channels that are in the MEMORY, first take unit out of SCAN (if in this mode previously). Press MEM button (9) and then press SCAN button (12). MEM and SCAN indicators will light.

6. To change from SCAN and MEM combination, press SCAN button, then press MEM button. (If only SCAN button is pressed, the UP or DN buttons will still lock in on the channels in MEM.) Pressing REV button changes SCAN operation.

TO LOAD MEMORY — Up to ten channels can be placed into memory. These channels can then be automatically sampled (SCAN) for BUSY or OPEN state; or manually sampled (UP or DN). Load the channels into SCAN/MEM as follows:

1. Change from SCAN and MEM if the respective indicators are lit.

2. Select desired channel with UP or DN button. When desired channel appears on channel indicator (16) press the LOAD button. This will place the desired channel into MEMOrY.

3. One channel, or any combination of channels, from two to nine, can be placed into memory. For example, channels 5, 6, 7 and 12 can be placed into memory eight times, and channel 12 one time. Channel 9 will automatically be included in the memory unless it is replaced by another channel after nine channels have been loaded.

4. To replace channel 9 with a tenth channel, load nine channels into memory. Press MEM button then go to channel 9 and press MEM button again. Select the channel to replace 9 then press the LOAD button.

5. If no channels are in memory, channel 9 will appear in channel indicator whenever MEM indicator is ON.

TO CLEAR MEMORY — Change from SCAN and press CLEAR button. This will clear all channels from MEMOrY except channel 9.

RADAR DETECTOR

A radar detector, figure 2-12, is included as a standard equipment item on your coach. This unit

is designed to activate when transmissions are received from radar-type speed detection equipment. Please remember: the purpose of the radar is to encourage caution — not speeding!

NOTE

Because some states have ruled radar detection equipment illegal, it is the responsibility of the driver or owner to obey the appropriate laws. (There are two thumbscrews that are provided which may be loosened for easy removal of the unit.)

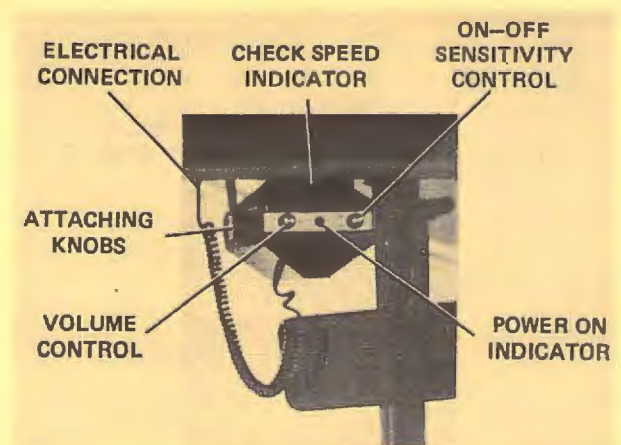

Figure 2-12. Radar Detector

CONTROLS AND INDICATORS — Operating controls and indicators are listed below:

CHECK SPEED Indicator — Provides flashing red warning light indicating radar detection.

ON-OFF Sensitivity Control — Applies power to unit and adjusts sensitivity threshold for maximum response.

VOLUME Control — Sets volume of audible warning signal.

POWER Indicator — Lights when power is on.

OPERATION — Although the detector is designed to prevent reception of false alarms, microwave telecommunications towers can sometimes cause a false alarm. The extreme sensitivity of the unit makes it most important for the driver to heed ALL warnings. Reflected radar scatter from a



moving radar, going in the same direction ahead of you, or behind you, can be detected by your unit. Remember, the unit can detect up to 10 times the effective distance of police radar!

Operate the radar detector as follows:

1. Turn on unit by rotating the ON/OFF sensitivity control clockwise past the "click". The green POWER indicator will light. The unit may beep a few times, then it will stop as it warms up.

2. After initial beeping has stopped, turn the sensitivity control clockwise again until a constant beeping is audible. Then back off the control in a counter-clockwise direction, slowly, until the beeping stops. The unit is now set at its highest sensitivity level.

3. Should the unit start beeping constantly at non-police radar signals (false alarms) turn sensitivity control counter-clockwise until the beeping stops. This de-sensitizing of the unit allows for its operation in heavily microwave-concentrated areas without excessive false alarms.

THE HORN (MUSICAL HORN)

The Horn, figure 2-13, is a sophisticated self-programmed electronic horn which can play a number of tunes available from an integral computer storage library.

The Horn incorporates the latest advancements in computer design and programming for the digital generation of music. All of the music, and programs to play the music, are stored in a "Read Only Memory" (ROM). The songs listed in the

window are those contained in the ROM, and may be played by selecting a combination of buttons 1 through 5. This memory will not be destroyed when power is disconnected from the unit, or if the switch is turned off. When a song is played of your own choosing, on the keyboard at the bottom of the panel, or a song played from the selected listing, the program is moved to a "Random Access Memory" (RAM) for execution. This memory is lost whenever power is removed. For this reason, the program is "down-loaded" from ROM to RAM. The heart of the computer, a micro-processor, then takes the program or instruction set and causes the music to be played.

OPERATING THE HORN — Operate the unit as follows:

1. Depress ON-OFF switch to apply power to the unit. Observe that indicator above the switch is lit.

2. Make your selection from the tunes available in the window and press the necessary combination of buttons 1 through 5 corresponding to the song. Release buttons which are not needed. Thirty-one selections are available.

3. Depress PLAY button to play tune.

4. To play your own selection, depress all five buttons, then depress PLAY. Now you can play the tune of your own choice on the keyboard at the bottom of the panel.

5. To turn the horn on without playing it automatically, use keyboard setting with all five buttons depressed. If any other combination of buttons are pressed, The Horn will play when the ON button is pushed.

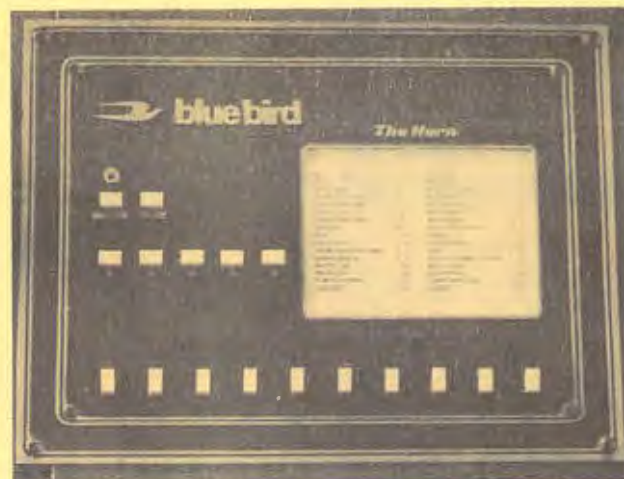

Figure 2-13. The Horn



RIGHT-HAND MONITOR PANEL

Located to the right of The Horn, as shown in figure 2-14, this panel contains the following condition status monitors and gauges:

DAY/NIGHT SWITCH — Adjusts back-lighting of panel markings from full to 1/2 intensity.

DOOR UNLOCKED INDICATOR — Lights when coach entry door is unlocked.

DRIVING LIGHTS INDICATOR — Lights when HEADLIGHTS switch is on and driving lights are functioning properly.

AUX. PUMP INDICATOR — Lights when power is being supplied to the auxiliary hot water circulating pump for the engine coolant line.

GEN. COMP. UNLOCKED INDICATOR — Lights when generator compartment tray is not in fully-closed position and locked.

COMP. LIGHT MASTER SWITCH — Operates lighting in all exterior compartments.

COMPASS UNIT — A high-precision marine-type compass, accurate to within 5 degrees, floated in a special fluid unaffected by temperature extremes.

ALTIMETER — Indicates coach height above sea level.

FILTER ELEMENT GAUGE — Indicates condition of filter in diesel fuel supply line. Water condensate level in filter is indicated when WATER IN FILTER switch is operated.

GEN. OIL GAUGE — Indicates oil pressure in the generator engine.

GEN. WATER GAUGE — Indicates temperature of generator engine coolant.

ENG. HR. METER — Indicates total hours of automotive engine operation.

GEN. HR. METER — Indicates total hours of generator engine operation.

WATER-IN-FILTER SWITCH — Operated to display amount of water condensate in diesel fuel filter; or pressed down for a self-test of the monitor circuit.

SAFELINE CONNECTION ALARM — Contains a buzzer ON-OFF switch and dual alarm indicators, one red, and one amber. This alarm device operates whenever the shoreline is connected to the coach and the 12-volt dc supply is also present, as a reminder to disconnect the shoreline before you drive away. The alarm is indicated by the buzzer sounding and the red indicator lamp lighting. The buzzer can be disabled in favor of the blinking amber indicator by setting the buzzer switch to the OFF position.

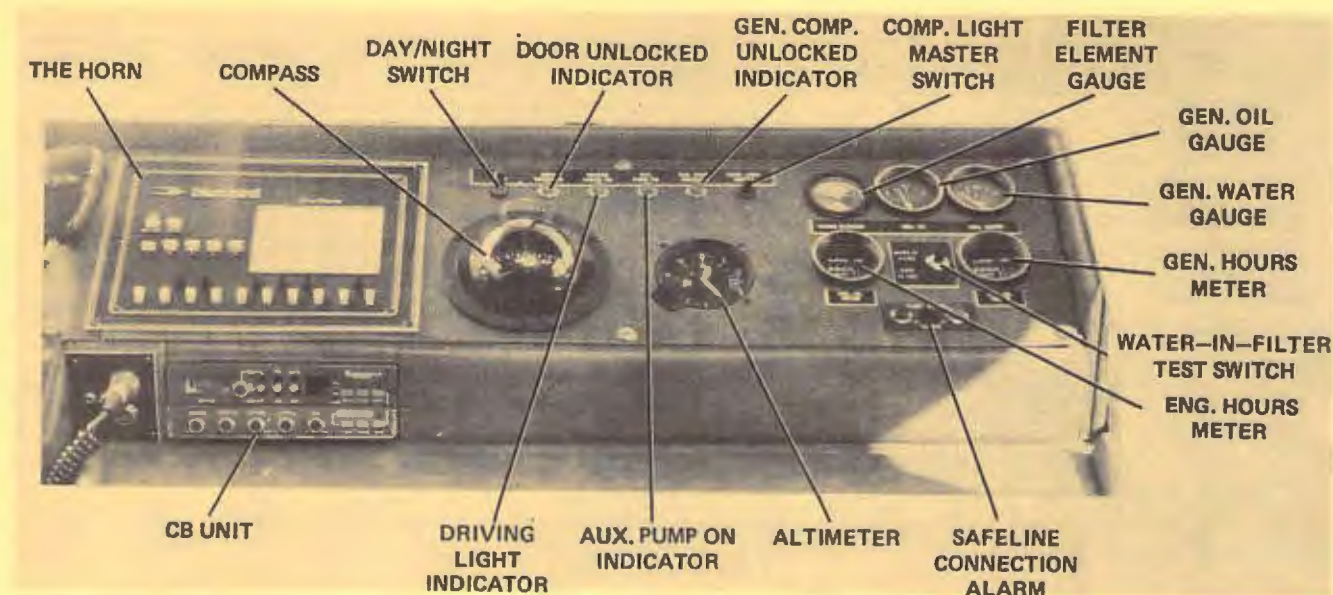

Figure 2-14. Right-Hand Monitor Panel



FLOOR CONTROLS

HIGH BEAM SWITCH — Press switch once to turn on high-beams (when normal headlights are on). Note that HI-BEAM light on dash is lit. Press the switch again to restore normal headlights.

AIR HORN FOOT SWITCH— Operates “highway” horns.

BRAKES — The coach is equipped with a dual air brake system which includes two independent systems for the front and rear service brakes. A separate reservoir and panel-mounted pressure gauge is provided for each service brake system.

ACCELERATOR — The accelerator pedal controls the speed of the coach by opening and closing the engine control fuel flow line. This pedal also controls the transmission low-gear kick-down mechanism to obtain rapid acceleration from slow speeds.

DIESEL ENGINE OPERATION

Proper operation and maintenance are key factors in determining the useful life and operation economy of a diesel engine. Follow the directions given here for trouble-free, economical engine operation.

TO START ENGINE — Caterpillar 3208 Diesel engines are designed to start at temperatures above 10 degrees F (–12 degrees C) without the use of a starting aid. If the temperature is below 10 degrees F a starting aid may be required and/or the crank-case oil may need to be heated with the engine block heater.

1. Place transmission in NEUTRAL.
2. Push accelerator pedal to half-speed.
3. Turn ignition switch to START. If engine fails to start within 30 seconds, release the starter switch and wait 60 seconds to allow the starter motor to cool before trying again.
4. As soon as the engine starts, reduce engine speed to low idle. Use throttle control on steering column as necessary to set idle speed.
5. Do not apply a load to the engine or increase engine speed until oil pressure gauge indicates

normal. Oil pressure should rise within 15 seconds after engine starts.

6. Operate the engine at low load until all systems reach operating temperatures. Check all gauges during warmup period.

AFTER ENGINE STARTS —

1. Reduce speed to low idle, with no load. When normal oil pressure is reached, run engine at low load for 5 minutes before applying full load. Rapid acceleration causes heavy exhaust smoke and high fuel consumption.

2. Accelerate to near-governed RPM. To avoid lugging, operate in a gear range low enough to permit the engine to accelerate under load.

3. Continue to accelerate until cruising speed is reached. Under load, maintain engine speed between 80% and 100% of rated RPM.

4. On upgrade, downshift if engine starts to labor. Downshift until a gear is reached in which the engine will pull without lugging.

5. **DO NOT LUG ENGINE.** Lugging results in excessive smoke and high fuel usage. A lug condition exists when an increase in engine speed cannot be achieved with an increase in accelerator pedal position; or when the engine speed decreases with the accelerator pedal floored. Do not lug engine below 2,000 RPM for more than several seconds.

6. On downgrades, do not coast or put transmission in NEUTRAL. Select the correct gear to keep the engine speed below high idle and retard the vehicle. A simple rule to follow is to select the same gear that would be used to go up the grade.

7. Before stopping the engine, operate at low idle for 30 seconds. This will allow hot areas in the engine to cool gradually, extending engine life.

DO NOT OPERATE THE ENGINE AT LOW IDLE FOR LONG PERIODS

TO STOP ENGINE — Turn ignition switch OFF.

TRAILER HITCH CAPACITY

Trailer hitch capacity is 5,000 pounds tow; 500 pounds tongue.



TOWING

CAUTION

Do not tow a vehicle equipped with Allison automatic transmission unless the rear drive shaft has been removed, or the rear wheels raised from the ground. Use caution when towing unit by front axle or cross-member. Damage to wiring and/or air lines can result because of proximity of these items to front cross-member.

TRANSMISSION START-UP INSPECTION

All Allison automatic transmissions delivered to an original retail purchaser of highway vehicles are eligible for a Transmission Start-Up Inspection if presented to an authorized Detroit Diesel Allison Service outlet within 90 days after delivery, or within 10,000 miles, whichever comes first. This inspection includes a complete check of the transmission installation and a road test to ensure that the transmission is operating satisfactorily. The inspection will be performed at no additional charge except for filter elements, lubricants and other maintenance materials. It is recommended that you take advantage of this service to realize the maximum benefits from your Allison-equipped vehicle. (Check the Yellow Pages under Transmissions - Truck or Engines - Diesel, for your nearest authorized service outlet.)

OPERATION

The Allison transmission provides four forward gears and one reverse gear. Speed selection is provided through the transmission shift lever located on the side wall, shown in figure 2-15.

The selector lever must be in N (neutral) position when the engine is started. If the engine can start in any other position, the neutral start switch is defective and should be replaced as soon as possible. Use D (drive) position for all normal driving conditions so that the coach begins moving in first gear and, as the accelerator is depressed, the transmission upshifts automatically into 2nd, 3rd, and

4th gears. As the coach slows down, the transmission automatically downshifts to the correct gear. Use a low gear (2nd or 3rd) when road, load or traffic conditions make it desirable to restrict automatic shifting to a lower range. When conditions improve, return range selector to normal D position. These positions also provide progressively greater engine braking action (the lower the gear range, the greater the braking effect). Use 1st gear when pulling through mud and snow or driving up steep grades. This position provides the maximum engine braking power. Use R (reverse) for backing the vehicle. The vehicle should be completely stopped before shifting from a forward gear to reverse. Reverse gear provides the greatest tractive advantage.

NOTE

In the lower ranges, 1st, 2nd and 3rd, the transmission will not upshift to the highest gear selected unless the recommended engine governed speed for that gear is exceeded.



Figure 2-15. Transmission Shift Selector



DRIVING TIPS

ACCELERATOR CONTROL — Foot pressure on the accelerator pedal influences the automatic shifting. When the pedal is fully depressed against the floor pedal stop, the transmission automatically upshifts near the recommended governed speed of the engine. A partially-depressed position of the pedal causes the upshifts to occur sooner at a lower engine speed. Shift timing is accomplished by using a cam and cable from the throttle. This method provides the accurate shift spacing and control necessary for maximum performance.

DOWNSHIFT CONTROL — The transmission can be downshifted or upshifted, even at full throttle, and, although there is no speed limitation on upshifting, there is a limitation on downshifting and reverse. Good driving practices indicate that downshifting should be avoided when the vehicle is over the maximum speed attainable in the next lower gear. Therefore, the good driving habits have been designed into the Allison transmission shift pattern for your benefit. The downshift inhibitors within the valve body prevent those harmful shifts when the vehicle is traveling too fast for the next lower gear.

If downshifts are attempted at excessive speeds, the inhibitors prevent the selected downshift until the vehicle reaches an acceptable speed.

USING THE ENGINE TO SLOW THE UNIT —

To use the engine as a braking force, shift the range selector to the next lower gear range. If the vehicle exceeds maximum speed for a lower gear, use the brakes to slow the vehicle to an acceptable speed until the transmission may be downshifted safely.

An automatic transmission, compared with a manual-shift transmission, has a longer "coast-down" time. Until becoming accustomed to this characteristic, it may be necessary to manually downshift to reduce speed.

With a little experience in driving with the automatic transmission, you will learn to decelerate a bit sooner, or brake until automatic downshift occurs. This will reduce the need for manual downshifting.

TRANSMISSION OIL TEMPERATURE

Extended operation at low vehicle speeds, with the engine at full throttle, can cause excessively high temperatures in the transmission. These temperatures may tend to overheat the engine cooling system as well as cause possible damage to the transmission. If excessive temperature is indicated by the engine coolant temperature gauge, stop the vehicle and determine the cause. If the cooling system appears to be functioning properly, the transmission is probably overheated. Shift to N and accelerate the engine to 1,200 to 1,500 RPM. This should reduce the oil sump temperature to operating level within a short time. If high temperatures persist, stop the engine and have the overheating condition investigated by service personnel.

CAUTION

Do not operate the engine for more than 30 seconds at full throttle with the transmission in gear and the unit stationary. Prolonged operation of this type will cause the transmission oil temperature to become excessively high and may result in severe overheating damage to transmission components.

If the transmission overheats during normal operation, check transmission oil level.

GENERAL INFORMATION — CATERPILLAR DIESEL ENGINES

Check crankcase oil level before starting and when refueling. Always check oil level with engine stopped. The dipstick has 2 markings, and the distance between them represents 3 quarts (2.8 litre). Use oils that meet any of the following engine service classifications:

- SC and SD (MS - Motor Severe Oils)
- CB (Supplement 1 Oils)
- CC (MIL-L-2104B Specification Oils)
- CD (MIL-L-2104C; Recommended Usage)

Use SAE 10W, 10W/30, 10W/40 or -30 grade oils, depending on the temperature.

CHECK (with engine stopped) fan, water pump and accessory drive belts for cracks, breaks and



frayed edges. Belts for multiple-groove pulleys are sold in matched sets. Replace, as a set, if one belt is defective. While checking belts, look for oil, water or fuel leaks.

CHECK (with engine stopped) for water in the fuel. Drain a cupful of fuel from the bottom of the tank to remove water or sediment. Fill fuel tanks after completing a run. Partially-filled tanks will collect moisture if the coach is allowed to sit for an appreciable length of time. Use Number 2-D diesel fuel (with a minimum cetane number of 40) in Caterpillar 3208 Diesel engines. Keep fuel clean. Inspect Racor filter bowl periodically and observe WATER-IN-FUEL indications on the

dashboard gauge. Remove and clean filter bowl as necessary.

Use Number 1-D diesel fuel in cold temperatures when white smoke must be minimized on starting up.

CHECK coolant level (with engine cool and off). Fill to the proper level with water and permanent-type anti-freeze. Adding Caterpillar Cooling System Conditioner to permanent-type anti-freeze is recommended if protection is above -20 degrees F (-29 degrees C). Use clean water that is low in scale-forming minerals, not softened water. Leave space for expansion.



SECTION III

LIVING AREA FACILITIES

INTRODUCTION

This section provides information on operation of the appliances and systems which contribute to the comfortable living conditions within your motorhome.

SOFA

To convert your sofa into a large double bed, on coaches that are so equipped, pull platform outward, lower and lock the supporting legs at each corner, and arrange rear cushions to completely cover platform area.

VACUUM CLEANER

The vacuum cleaner system, figure 3-1, is completely self-contained and supplied with a long flexible hose and wand, carpet, upholstery and crevice tools. Install the flexible hose end-fitting into the corresponding intake hole, accessible when the spring-loaded door is swung aside. The disposable paper bag, located in the compartment to the right of the intake, is easily removed and replaced when the compartment door is opened (vacuum cleaner should be off when changing bags). A new bag is installed by sliding the cardboard ring on the bag over the intake tube. Clean or replace foam filter

periodically to keep system operating efficiently. Note that vacuum cleaner will shut off automatically when the bag is full.

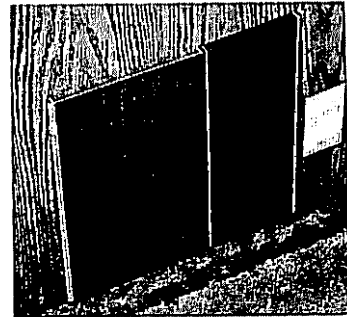

Figure 3-1. Vacuum Cleaner System

DINETTE AREA

The dinette area, figure 3-2, includes the convertible dinette table, thermostat, door chime and Lifeguard One, on the rear wall. The dinette table is attached to the wall by two hooks and brackets and is held erect by a single folding leg. To convert the dinette to a bed, fold leg upward, lift table upward and outward from wall brackets and carefully lower it to rest on overhang edges at front of each dinette seat. Unhook seat back cushions from each dinette seat and place sideways across the gap formed by the table surface, completing the bed conversion.

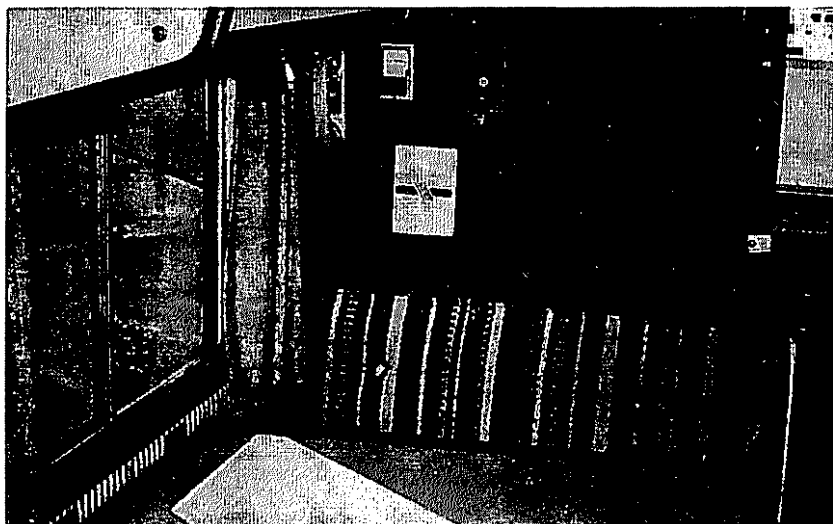

Figure 3-2. Dinette Area



GALLEY FACILITIES

The galley, figure 3-3, includes a double sink, built-in toaster compartment, food center, refrigerator/freezer combination, gas range and oven. On the left galley wall are mounted two power line monitors, a carbon monoxide detector, The Clock and Monitor. Above the galley, on the overhead panel, is located a monitoring and switching panel. The refrigerator, toaster and food center are designed for operation on 120 volts ac, as supplied by the internal generator plant, or via the external shoreline hookup. The refrigerator can also be operated from the LP gas supply, as are the range and oven. The turn-on and operating procedures given in the following paragraphs assume that the LPG tank is filled and the main gas valve is on.

REFRIGERATOR

Understanding just how the refrigeration process operates will help to explain one of the important reasons why it is necessary to level a parked motorhome. The gas-fired (or electrically-heated) boiler converts the ammonia-water solution to distilled ammonia vapor, which is carried to the finned condenser, where it liquifies. The liquid flows to the evaporator, where it creates a cooling effect by evaporating into a circulating flow of hydrogen gas. If the evaporator coil is not level, the liquid accumulates, forming pockets which do not readily evaporate and impair or block gas circulation, inhibiting the cooling process.

When the coach is parked, it must be leveled to assure comfortable living accommodations. If the refrigerator is properly installed, with the freezer shelf parallel to the ground level, the refrigerator will then also perform well. This can easily be checked by placing a bubble level on the freezer shelf. When the vehicle is moving, the continuous rolling and pitching movement will not affect the refrigerator as long as the movement passes either side of level; but when the coach is parked, the refrigerator must be leveled.

The operation of a thermostatically-controlled fan in the refrigerator compartment is controlled by the REFRIG FAN ON-OFF switch located on the wall panel above the sink. Refer to figure 3-4 for location of refrigerator controls for gas and electric operation.

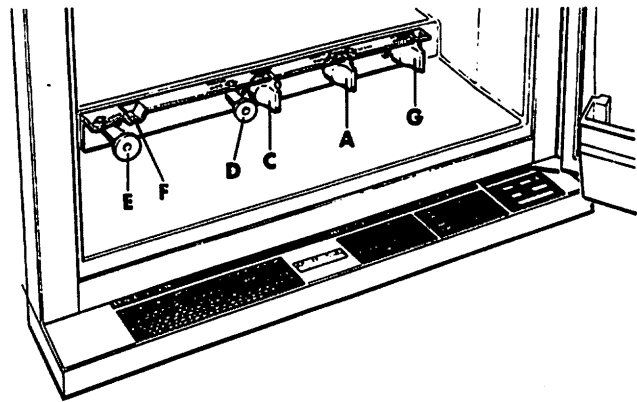

Figure 3-4. Refrigerator Operating Controls

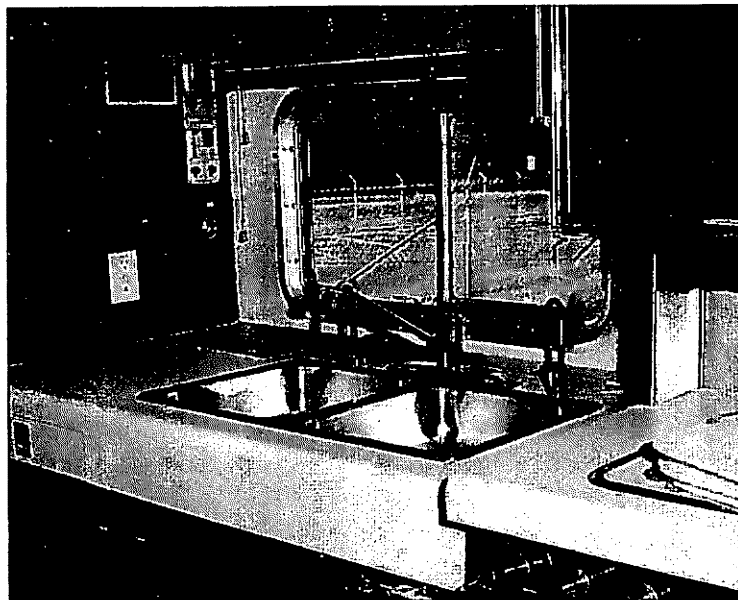

Figure 3-3. Galley Facilities



GAS OPERATION — Proceed as follows:

1. To start the refrigerator, set knob A to GAS position. This opens the LPG valve and disables the electric circuits.
2. Turn gas thermostat knob C to 4 position.
3. Pull outward and hold knob D while pressing piezo lighter button E. Look through reflector F to see if burner is lit. It may be necessary to operate button E more than once to ignite the gas pilot.
4. After gas is lit, hold knob D in outward position for an additional 15 seconds, then release knob and observe that burner flame stays lit.

NOTE

After LPG tank has been refilled, or after a long shutdown period, gas lines may become filled with air. If this occurs, repeat lighting procedure until air is evacuated from lines and gas has reached the burner.

ELECTRIC OPERATION — Proceed as follows:

1. Check that refrigerator ac line plug is properly connected to the 120 volts ac supply outlet and that ac power is available.
2. Set knob A to OFF position then press knob inward and turn to desired electric position.
3. Turn thermostat knob G to 4 position.

USING THE REFRIGERATOR

FOOD STORAGE COMPARTMENT — To maintain required low temperatures for food storage, the food storage compartment is completely closed and unventilated. Consequently, foods having a strong odor, or foods liable to absorb odors, should always be covered. Cover vegetables and salads to retain crispness. The coldest locations within the refrigerator are beneath the cooling evaporator and on the lowest shelves; the least cold locations are on the upper door shelves. Consider this when storing different types of food.

DEFROSTING — Keep the refrigerator operating at maximum efficiency by periodic defrosting and cleaning. Wash ice trays and shelves with warm water. **DO NOT** use strong chemicals or abrasives. During extended periods of storage, empty and

clean refrigerator and leave door slightly ajar to reduce buildup of musty odors.

Refrigerators are equipped with an automatic defrosting device incorporated within the cooling unit. This device makes a quick defrost of the finned evaporator section about once each day without affecting the frozen foods stored in the freezer compartment. When the frozen food storage compartment is covered with frost, shut down refrigerator until frost is melted. Before restarting refrigerator, dry compartments, wash and fill ice trays with fresh water.

Water will collect in the drip tray when frost on the finned evaporator section has melted. Empty drip tray at regular intervals. If it is necessary to shut down the refrigerator for defrosting, empty the refrigerator, leaving the drip tray beneath the finned evaporator, and leave cabinet and freezer doors open. When all frost has melted, empty drip tray, if necessary, and dry refrigerator interior with a soft clean cloth. Replace all foodstuffs and set thermostat to MAX position for a few hours. Then reset the thermostat knob to its normal position.

FROZEN FOOD COMPARTMENT — Quick-frozen soft fruits and ice cream should be placed in the coldest part of the compartment, at the bottom of the aluminum liner or, in models with a shelf, on or just below the shelf. Frozen vegetables may be stored in any part of the compartment.

The freezer compartment is not designed for deep or quick freezing of foodstuffs. Meat or fish foods, whether raw or prepared, provided they are pre-cooled in the refrigerator, can be stored in the frozen food storage compartment about three times as long as in the normal temperature compartment. To prevent dehydration, keep food in covered dishes, in plastic bags, or wrapped tightly in aluminum foil.

ICE MAKING — Place ice trays in direct contact with freezer shelf for fastest ice making. Fill trays with water to within ¼ inch from the top. To release ice cubes pull handle upwards. Return unused cubes to the tray. Refill tray with water, dry outside, replace in frozen storage compartment. Clean compartment with dry cloth.



The ice-making process can be accelerated if the thermostat is set to MAX position. It is a good idea to do this for a few hours before an anticipated need for ice, but be sure to turn back the thermostat to its original setting when the ice is formed, or the foodstuffs in the cabinet may also become frozen. (Ice-making time is also reduced if unused cubes are left in ice trays when they are refilled with water.)

REFRIGERATOR SHUTDOWN — For temporary shutdown, set thermostat to zero position and turn off the gas valve. If the cabinet is to be shut down over a period of weeks, it should be emptied and cleaned, and the door left ajar. Ice trays should also be dried and kept outside the cabinet.

CAUTION

If the refrigerator is used only intermittently it should be checked at least once each year.

CLEANING — Clean cabinet interior lining with a lukewarm weak soda solution. Clean evaporator, ice trays and shelves with warm water only. DO NOT use strong chemicals or abrasives to clean these parts or protective surfaces may be damaged. Always keep cabinet clean.

CAUTION

Do not use refrigerator for storage of flammable fluids.

GAS RANGE AND OVEN

The gas supply for the range burners and oven, figure 3-5, is provided from the LPG tank. Make sure that the main valve (on tank) is turned ON before lighting pilots.

CAUTION

It is a good safety practice to leave oven control in TOP AND OVEN PILOTS OFF position (maximum counter-clockwise) when oven is not in use or while unit is in motion.

LIGHTING PILOTS — To light range and oven pilots, set oven control to OVEN OFF position then hold a match near range pilot (lift up burner

top surface to gain access to burner pilot); and then hold a match to oven pilot (located above and to the right of oven main burner).

LIGHTING RANGE BURNER — Once the range pilot is lit, light the desired range burner by pushing in and turning the respective burner control knob counter-clockwise.

NOTE

The oven in your motorhome has an automatic lighting device. There will usually be a short delay (30 to 40 seconds) after the oven is turned on before the burners will light. This is a normal condition and is not a sign of an oven malfunction.

LIGHTING OVEN BURNER — Once the oven pilot light is lit, turn oven control to desired temperature setting and oven burner will light automatically and maintain correct temperature.

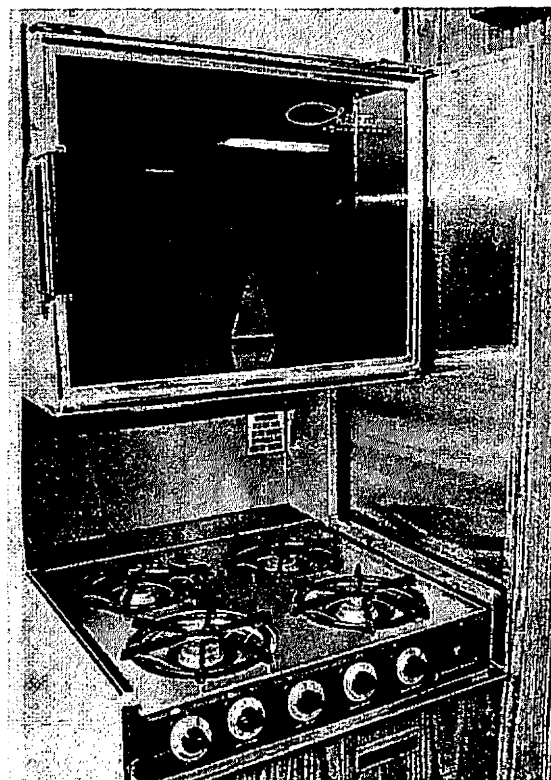

Figure 3-5. Gas Range and Oven.



SHUT OFF RANGE AND OVEN BURNERS —

Turn oven control to **TOP AND OVEN PILOTS OFF** position (maximum counter-clockwise).

GALLEY SINK

The heavy-gauge stainless steel sink provides maximum durability with minimum care. After use, rinse sink thoroughly with warm water and wipe dry with a cloth to avoid streaks and spots. For stubborn stains, a mild abrasive cleaner can be used with care. Be sure to wipe in the direction of the steel finish to help maintain the original appearance. Always wash counter surfaces before applying a complete wax coating; regular cleaning prevents wax buildup.

CAUTION

Abrasive cleaners will scratch sink counter top surface.

Boiling water will not harm stainless steel; however, salt, mustard, mayonnaise, ketchup and other similar food acids can cause pitting. If any of these are spilled on the surface, clean off immediately.

FOOD CENTER

A built-in variable-speed motor-driven counter unit, figure 3-6, may be used with mixing and blending attachments for a large variety of food preparation tasks. The food center is designed for

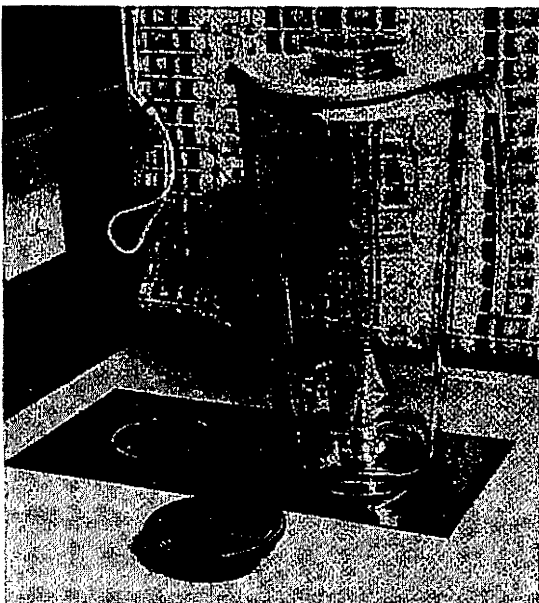

Figure 3-6. Food Center

ac operation and is operable only when the generator is on; or when coach systems are connected to an external shoreline hookup.

BATHROOM

WATER PUMP SWITCH

Two **WATER PUMP ON-OFF** switches are provided: one is located on the wall control panel above the sink; the other switch is located in the bathroom. Set switch to **ON** position to pressurize the water system. The pump operates upon demand to keep system pressure constant. Continuous or erratic pump operation is an indication of an empty water tank, system leakage, or the presence of air lock in the hot or cold water lines. (Air locks are normally caused by movement of water within the tank while pump is operating.) Tank water level and water pressure can vary with road movement. To avoid this condition, leave water pump switch **OFF** while the unit is in motion. Note that water pump and air accumulators are located beneath the bathroom vanity, in side-bath units; and under the left bed, in rear-bath units. The water filter purifier (optional) and pressure switch are located under the kitchen sink.

SHOWER

To use the shower, figure 3-7, use the push/pull mixing valve and adjust the water temperature to suit. Turn shower water off and on during use by operating pushbutton on shower head.

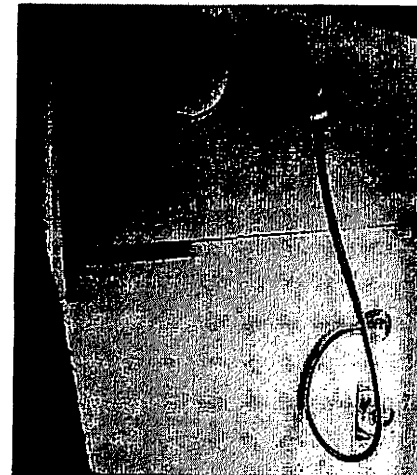

Figure 3-7. Stall Shower



TOILET

The toilet (marine type), figure 3-8, operates from the fresh water supply, flushing wastes directly into the sewage holding tank. Two foot pedals are located at the bottom of the bowl. The smaller right-hand pedal (bowl fill) controls the amount of water delivered into the bowl; while the left-hand pedal (bowl drain) opens the sliding valve to the tank. To prepare the toilet for use, depress the bowl fill pedal until the water level in the bowl is as high as needed. After use, depress bowl drain pedal until water swirls, draining wastes into tank, then release pedal. A water-saver feature, consisting of a manually-operated spray hose, is located at the side of the bowl.

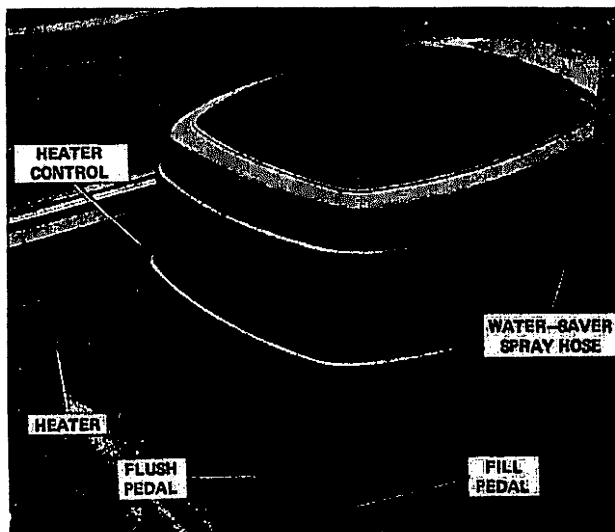

Figure 3-8. Toilet

ROOF VENTS AND EXHAUST FANS

BATHROOM — To operate the combination vent/exhaust fan in the bathroom ceiling, figure 3-9, turn handle to open roof vent, then press switch to turn on fan motor.

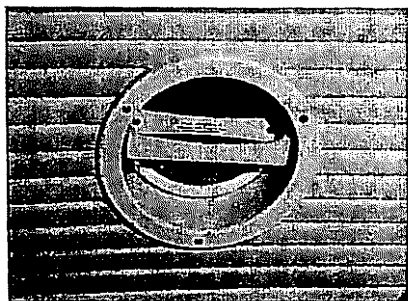

Figure 3-9. Bathroom Vent/Exhaust Fan

HALLWAY — The lighted exhaust fan in the hallway ceiling, figure 3-10, is electrically controlled by three switches located on a panel above the oven, as shown in figure 3-11.

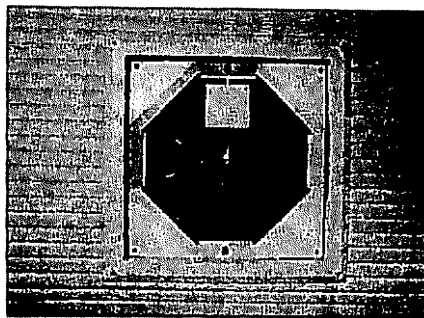

Figure 3-10. Hallway Lighted Vent/Exhaust Fan

The LID UP-DOWN switch raises or lowers (closes) the outside vent; the FAN ON-OFF switch controls fan operation; and the LIGHT ON-OFF switch controls the operation of the built-in ceiling light.

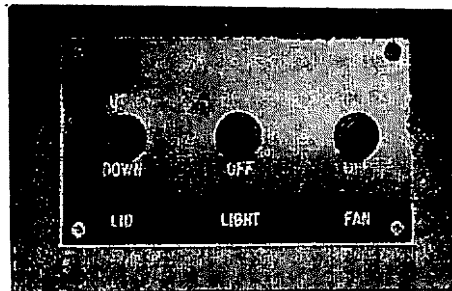

Figure 3-11. Exhaust Fan Control Panel

HEATING SYSTEMS

Three gas/hot air furnaces are used in the coach, each with a separate zone thermostat, figure 3-12.



Figure 3-12. Heater Thermostat



One furnace is located in the living room; another in the galley area; and the third in the bedroom. In addition, separate heating is also provided by circulating hot-water heaters which function through engine coolant heat exchange when the engine is operating, and the SUM. HEAT/WIN. HEAT dash switch is in WIN. HEAT position. A third type of heating, electric heat, is used in the bathroom and at other (optional) locations in the coach.

HOT AIR FURNACE OPERATION

To operate the furnace, proceed as follows:

1. Turn manual valve to OFF position and wait five minutes. Set thermostat to lowest setting.
2. Open manual valve. Correct operating characteristics depend on this valve being fully opened; never operate with valve partially open!
3. Set thermostat at desired position. Main burner will light within 15 seconds and furnace will then operate automatically.

When coach temperature drops below the thermostat setting, the internal relay contacts close to operate the main burner. The air flow created by the blower closes an air-actuated switch that, in turn, energizes the main burner gas line solenoid valve which then lights from the electronic ignition.

CAUTION

Do not store items in or near the burner compartment.

When the coach temperature exceeds the thermostat setting, the relay contacts open. This shuts off the burner gas supply but the blower continues to operate until residual heat within the furnace is dissipated, when a thermostatically-controlled relay turns off the blower. Air for the sealed combustion chamber is pulled in from outside the coach, routed around the heat exchanger, then exhausted through the same vent. Recirculated fan-forced air blowing across the heat exchanger is used to heat the coach interior.

HOT-WATER HEATING SYSTEMS

Two sources of hot-water heating are provided which depend on heat generated from engine

operation. A hot-water heater, at the right front corner of the coach, is controlled by the FRONT HEAT switch on the dashboard; and three chassis heaters, (50,000 BTU) under the front dinette seat, front sofa and curb-side bed, are controlled by the CHASSIS HEAT thermostat, located on the curb-side wall, above the half-closet, nearest the entry door.

The engine coolant is normally routed through the engine cooling system and the hot water heat exchanger, which also can be heated electrically to provide the hot water supply for the coach. However, by operating the SUM. HEAT/WIN. HEAT switch, on the dash, the engine coolant can also be diverted through the previously-mentioned area heaters, via solenoid valves. Note that the coolant level in the engine radiator should be checked after these valves are opened. If the coolant in the heater lines has evaporated during the summer, the radiator will lack sufficient coolant and may overheat.

Dual-speed switches are located adjacent to each heater. Pull the switch outward to the first position for low-speed fan operation; pull the switch out to the last position for high-speed operation.

The front heater is equipped with three large squirrel-cage two-speed blowers which are operated by separate controls on the driver's instrument panel. One blower is used for defogging; one provides hot air to the driver; and the remaining one provides hot air to the co-pilot's side. To supply heat, the FRONT HEAT switch on the dashboard must be ON.

NOTE

If additional defrosting action is needed, turn auto air conditioning temperature control to OFF and turn auto air conditioning fans to high-speed. This will circulate additional warm air about the windshield area.

Engine heat is picked up by the engine coolant which is pumped through the heaters inside the body and back into the engine. A typical heater (inside the body) consists of a heat exchanger, or core, and fans which move the air across the core. Air moving across the core picks up heat from the



engine coolant and transfers it into the living room.

HEATING SYSTEM OPERATION

Satisfactory performance of this type of heating system depends on the following basic factors:

1. **Engine Coolant Temperature** — This can be altered by thermostat rating, which should never be higher than that recommended by the engine manufacturer.

2. **Coolant Flow** — This varies with the engine speed. Setting the AUX. PUMP dash switch to ON turns on the auxiliary pump in the coolant lines to increase the coolant flow through the system. (This feature may also be used to reduce engine overheating.)

3. **Proper Fan Operation** — All fan motors are two-speed and can easily be checked for proper operation by listening to the motor speed change as the switch is operated.

Under extremely cold weather conditions, turning on the heater fans will lower the engine temperature noticeably as heat from the engine is being transferred into the body. However, as the air temperature within the body rises, the engine temperature will also increase. More heat will be generated by the engine which it is also used to move the coach. Be sure that the engine radiator is full and that all coolant flow valves are open.

Warmup engine to operating temperature and set heating system switches as follows:

- a. SUM. HEAT/WIN. HEAT to WIN. HEAT;
- b. AUX. PUMP to ON; and
- c. L.H. and R.H. HEAT BLOWERS to ON.

The engine is designed for operation on a continuous duty cycle and, when parked, may be run continuously to provide a constant heat supply. This, however, should be done only during extreme cold weather conditions where no other source of heat is available.

ELECTRIC HEATER

A separately-controlled electric heater is used to provide fan forced hot air in the bathroom, as shown in figure 3-8. A thermostat control is at

the right side of the fan grillework.

HOT WATER SUPPLY HEATER

The hot water supply heater core is also a part of the engine cooling system loop. When the engine is operating, the heat exchanger ensures a constant supply of hot water. In addition, the water supply can be electrically heated by electric coils in the heater unit. The 120 volt ac electric heater core is controlled by the operation of an ON-OFF switch on the bottom of the roadside bed; or by the circuit breaker in the rear curbside closet. This heater can operate only when the shoreline is connected, or when the generator is on.

CAUTION

Be sure that the electric heater core is turned OFF if there is insufficient water in the tank.

AIR CONDITIONING

Conditioned air is maintained throughout the coach by ceiling-mounted air conditioner units. Each unit provides dual low- and high-speed fan or cooling operation for high velocity air movement through individually-controlled outlets. Air conditioning cool-down occurs faster if all windows, doors and vents are closed.

Maximum air conditioning efficiency also depends on the outside temperature and operating voltage level. Because the air conditioners represent the largest load for the electrical system, never start more than one unit simultaneously. (Air conditioner starting current can be two to three times the normal operating current.)

CAUTION

To ensure the full efficiency of the air conditioning units, periodic removal and washing of the air conditioner filters is recommended. This is easily done by removing the filters from the retaining screens, washing in a warm soapy solution, rinsing and drying with paper toweling, then replacing filters and screens.

If an external ac hookup is being used, and the system is not operating efficiently, this may be



caused by lower shoreline supply voltage. (Check power line voltage monitors.) Turning the generator on and switching over to generator operation will supply enough power to ensure correct air conditioner operation.

Before starting the generator, check that each air conditioner is off to prevent the generator from starting under load. Allow generator to warm up to the proper voltage and frequency before turning on the air conditioner(s).

Two remote ON/OFF switches for REAR and FRT. A.C. operation are located on the wall next to the driver.

SYSTEMS MONITORING AND CONTROL PANELS

Systems monitoring and control panels are located in the galley walls, above and to the side of the sink, figure 3-3. Additional monitoring equipment is provided on the dinette wall, figure 3-2.

THE CLOCK AND THE MONITOR

Both of these units, figure 3-14, are solid-state with large digital LED readouts. Operating procedures for each unit follows:

THE CLOCK

1. Press POWER ON button, applying power to both The Clock and The Monitor.
2. Set clock time by operating FAST and SLOW buttons, as necessary, until correct time is shown.
3. Set alarm as follows: press ALARM DISPLAY button then operate FAST and SLOW buttons to set the alarm time. Note that this is a 24-hour alarm, so observe the lit AM and PM indicators to the left of the display. After the alarm is set, press ALARM DISPLAY button again to return to normal time mode. To activate the alarm feature, press the ALARM ON button; to shut off the alarm, press ALARM OFF button.
4. To display seconds, press SEC DISPLAY button and the display will show the last digit of the minutes, and the seconds changing. Press SEC DISPLAY button again to restore normal readings.

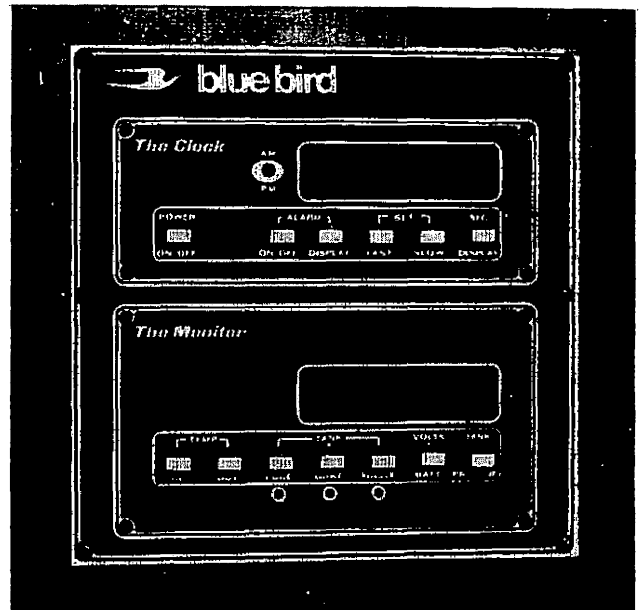

Figure 3-14. The Clock and The Monitor

THE MONITOR — The Monitor panel permits easy access to a readout of inside and outside temperatures; content level (in percent) of pure, gray, and waste water tanks; battery voltage; and LPG tank level. To use The Monitor, proceed as follows:

1. Monitor inside or outside temperature (F) by pressing the TEMP IN or TEMP OUT buttons, respectively. Note that there is an internal adjustment, at the rear of the unit, which may be used to calibrate the readings.
2. Monitor PURE, GRAY, or WASTE TANK levels by pressing the respective button. Note that PURE TANK readout may be calibrated at the front panel, if necessary. For correct adjustment, fill the pure water tank, then press the PURE TANK button. Using a small screwdriver, vary the adjustment accessible beneath the PURE button until the display reads 100 (percent). The readouts for GRAY and WASTE TANK levels may be calibrated in the same manner, using the corresponding adjustments beneath each button. However, the tanks must be full to determine the 100 percent setting.
3. Press BATT. VOLTS button to read coach battery voltage.
4. Monitor percentage of LPG tank level by pressing PROPANE TANK button. This display is pre-calibrated. However, if adjustment is necessary, such is provided on the rear panel.



SWITCHING AND MONITOR PANEL

The switching and monitor panel above the sink, figure 3-15, monitors battery voltage for low-level conditions, and activates an audible alarm if a low-voltage condition is present (BATTERY LOW VOLTAGE). It also monitors refrigerator temperature when the REFRIG. ALERT switch is ON. Normally, the ON indicator will be lit; if the refrigerator temperature increases to an unsafe level, the WARM indicator will be lit, to indicate an alarm condition. The thermostatic refrigerator fan is controlled from this panel by the REFRIG. FAN ON-OFF switch. The indicator above the switch is lit when the fan is ON.

Water pump operation may also be controlled from this panel with the WATER PUMP ON-OFF switch; the ON indicator will be lit when power is being supplied to the pump. GENERATOR START-STOP operation is controlled by depressing the switch upward to start the generator, operation being indicated by the indicator in the center of the switch being lit; press switch downward to STOP operation and hold until light is off.

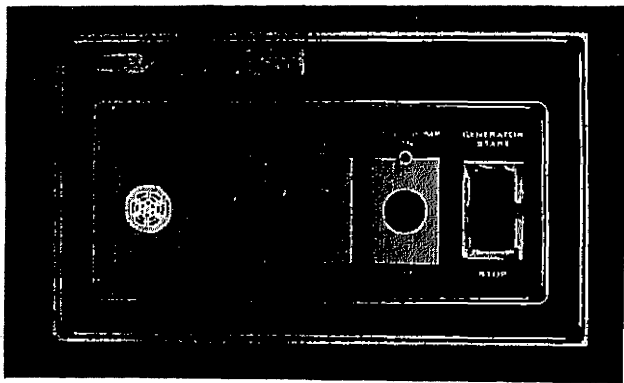

Figure 3-15. Switching and Monitor Panel

CARBON MONOXIDE DETECTOR

The carbon monoxide detector, figure 3-16, is located on the left wall above the sink. This unit provides continuous monitoring when the OFF-ON switch is set to ON position. To test unit operation, operate PUSH AND HOLD TO TEST switch and listen for audible alarm.

POWER LINE MONITORS

Two power line monitors, figure 3-16, continuously monitor ac line voltage and polarity of the shoreline hookup(s). Each unit has an expanded-scale ac voltmeter, reading from 90 to 130 volts; a POLARITY NORMAL indicator, lit whenever the shoreline hookup is properly connected and grounded, and the line polarity is compatible to coach wiring; and a POLARITY REVERSE indicator to show that the hookup is reversed.

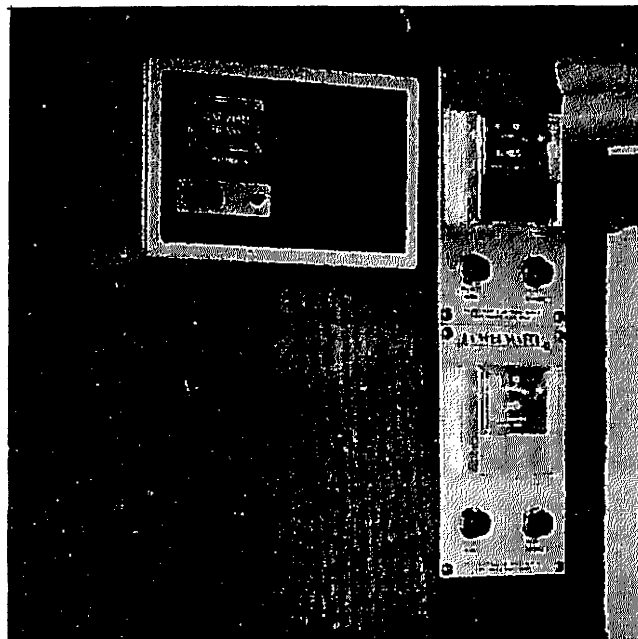

Figure 3-16. Carbon Monoxide Detector and Power Line Monitors

LIFEGUARD ONE

Lifeguard One, figure 3-17, is a gas leak detector designed to detect dangerous concentrations of propane or butane gas within the coach.

Propane has a Lower Explosive Level (LEL) of 21,000 PPM and butane has an LEL of 18,000 PPM. The Threshold Level Value (TLV) is the maximum permitted level of toxic gas permitted in a work area, as published by safety and health authorities (OSHA). The allowable TLV for propane is 1,000 PPM. (The TLV for carbon monoxide is 50 PPM!)

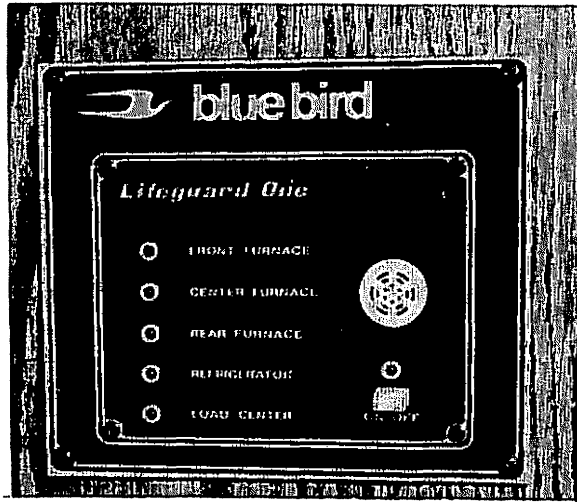

Figure 3-17. Lifeguard One Gas Level Alarm

Lifeguard One has been factory-calibrated to an alarm point of 2,000 PPM propane for standard conditions (temperature, 20 degrees C +/- 2 degrees; relative humidity 65% +/- 5%). This provides for a minimum of false alarms consistent with providing reasonable safety.

Carbon monoxide, a product of combustion, is also sensed by Lifeguard One and, for this reason, a sensor is also placed at the load center to provide an alert in the event of a short circuit causing an electrical fire. The sensors have a long life and high reliability. In normal use, recalibration or replacement will not be necessary for 5 years or longer.

To turn on the unit, set ON-OFF switch to ON and observe that POWER ON indicator is lit. Propane level sensors are located in key areas through the coach, in the vicinity of the gas appliances being monitored. Excessive propane PPM conditions are indicated by the sounding of the audible alarm and lighting of an indicator associated with the danger area. Lifeguard One, if left turned off for a period of time, has a warmup period of about one minute. During this time, the alarm may sound. This is a normal response and should stop once the unit has warmed up.

ELECTRONIC DOOR CHIME

The door chime is located on the dinette wall beneath Lifeguard One. It is a highly sophisticated musical tone generator similar to The Horn.

The unit contains a circuit board micro-computer "chip" which is programmed with both music for the tunes, and the play-out program.

When the entry door button is pressed, the micro-computer is activated and tests the selection switches to find out which tune is required. When this is done, it proceeds to retrieve the tune from "memory" and then generates the audio/tune output. Since this is all done electronically (in a fraction of a second) the unit cannot go out of tune. The audio signal is amplified and processed to sound similar to a chime, and then connected to the speaker. When the end of a tune is reached, as long as the entry button is not being pressed, the micro-computer shuts down to save power use.

The operating controls are concealed behind the lower access panel, as shown in figure 3-18. The panel may be removed at any time to change the tune played, or the speed, volume, or tone.

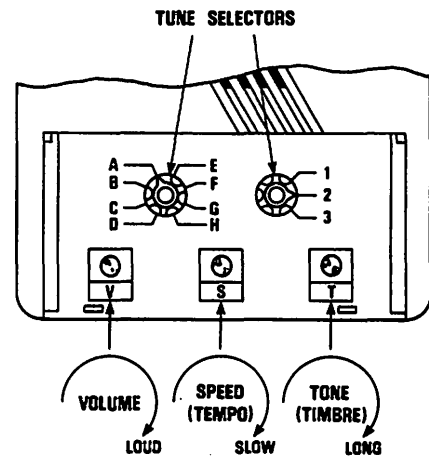

Figure 3-18. Electronic Door Chime Controls

TUNE SELECTION — The desired tune is selected by setting the two operating controls to the positions corresponding to the following selections:

Tune	Set
Greensleeves	A1
God Save the Queen	B1



Tune	(continued)	Set
Rule Britannia		C1
Land of Hope and Glory		D1
Oh Come All Ye Faithful		E1
Oranges and Lemons		F1
Westminster Chimes		G1
Sailor's Hornpipe		H1
Cook House Door		A2
Star Spangled Banner		B2
Beethoven's Ode to Joy(9th)		C2
William Tell Overture		D2
Soldier's Chorus (Faust)		E2
Twinkle, Twinkle Little Star		F2
Great Gate of Kiev		G2
Maryland/Tannenbaum		H2
Beethoven's Fate Knocking		A3
The Marseillaise		B3
Glorious Things/Deutschland		C3
Bach's Tocata in D Minor		D3
Mozart Sonata		E3
Colonel Bogie (Bridge Over River Kwai)		F3
Mendelssohn's Wedding March		G3
The Lorelei		H3

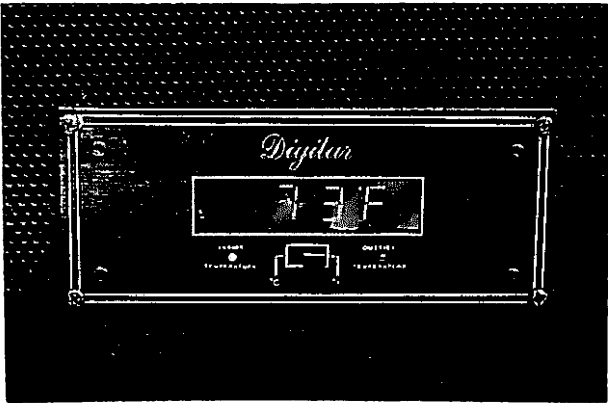

Figure 3-19. Digital Inside/Outside Thermometer

Two probes are used with the unit: one probe monitors the inside temperature near and around the instrument; the second probe monitors outside temperature. The unit is equipped with a scale selector switch which allows the display to read out in either degrees F or degrees C. When set to the left, the display provides a number followed by C, for degrees Celsius readings; set switch to the right for degrees Fahrenheit readings.

Note that the thermometer includes an automatic scanning feature which will continuously monitor and switch between inside and outside temperature readings. When the green INSIDE TEMPERATURE indicator to the left of the selector switch is lit, the reading is for inside temperature; correspondingly, when the OUTSIDE TEMPERATURE indicator is lit, the reading reflects the outside temperature.

It is important not to use cleaning chemicals or abrasive toweling (paper towels or kleenex) on the faceplate or plastic display window as these will scratch the surface. Use only a soft cotton cloth and a liquid plastic cleaner.

FIRE EXTINGUISHER

A portable, multi-purpose dry chemical fire extinguisher is located beneath the forward part of the dinette seat, in side-bath units; and in back of the driver's seat, in rear-bath units. To use, release the clamp and remove the fire extinguisher from the bracket. Pull safety pin from the handle, squeeze handle, and apply chemical under flame.

On all selections, except A1 and A2, the second pushbutton will only play tune A3. If A1 or A2 is selected, then it will play B3.

The knob designated S sets playing speed for the selected tune; the T knob sets the tone and may be adjusted for a pizzicato sound (plucked strings); or, set for normal audio tones. The knob marked V sets the volume. When set to the fully counter-clockwise position, no sound will be heard, but the unit will still be operational.

After setting all controls, replace access panel.

DIGITAL INSIDE/OUTSIDE THERMOMETER

The digital inside/outside thermometer, figure 3-19, is located in the driver's compartment, top center bulkhead panel.

Because of the long-life design and low power consumption, it is unnecessary to shut off the unit, so an on-off switch is not required. The thermometer is factory-calibrated and requires no further adjustment during use.



TV ANTENNA AND ROTATOR SYSTEM

The control components of the antenna and rotator are a hand-held switch-operated rotator, radome-type TV roof antenna, and a coupler-switcher for the antenna or cable inputs. The rotator control and the coupler are located within the compartment above and to the left of the driver, as shown in figure 3-20.

The A-C switch on the coupler selects antenna (A) or cable (C) input (via CABLE connection in shoreline receptacle/water hookup compartment at the left rear of the coach). Two additional switches on the coupler route the antenna/cable inputs to their destination; and select from the antenna inputs, when more than one is available.

The antenna rotator controls the position of the TV antenna housed within the roof antenna radome. The three-position momentary switch (center-off) provides right-left antenna rotation, antenna position being displayed on the associated dial face. The rotator power supply is also located in the radome.

The antenna and rotator system is a completely new type of TV antenna system designed for use on recreational vehicles, boats and residential dwellings. Under average conditions, the reception range of the antenna is 35 miles from the TV transmitter station. The system contains a miniaturized unidirectional antenna, special solid state amplifier and an electrical rotating mechanism, all housed in a weatherproof "radome". The remote power

supply is designed to operate from either 120 volts ac or 12 volts dc (negative ground). The package also includes a VHF/UHF band separator, rotator control unit with illuminated direction indicators and stainless steel hardware.

A 30-foot length of low-loss coaxial cable with a screw-type connector on each end, and a 3-wire rotator cable to interconnect the antenna and power supply complete the installation. Both of these cables are contained in a prefabricated, single-jacket cable assembly included with the unit.

Note that a .8 ampere fuse is connected in series with the 12-volt dc supply line to the unit. In the event that the TV set exhibits problems relating to low antenna input ("ghosts", etc.) check this fuse before servicing the TV set.

OPERATION

With the TV on and a station tuned in, rotate the antenna by pressing the rocker switch located on the control unit. Press the right side of the switch to turn the antenna clockwise; press the left side to turn the antenna counter-clockwise. Although the actual antenna movement is not visible, the indicator arrow on the control unit lights and shows the direction of the antenna. When the antenna has made one full turn (360 degrees), the End of Rotation light comes on. Observe the picture while rotating the antenna, first in one direction, then the other, until the best picture quality is obtained.

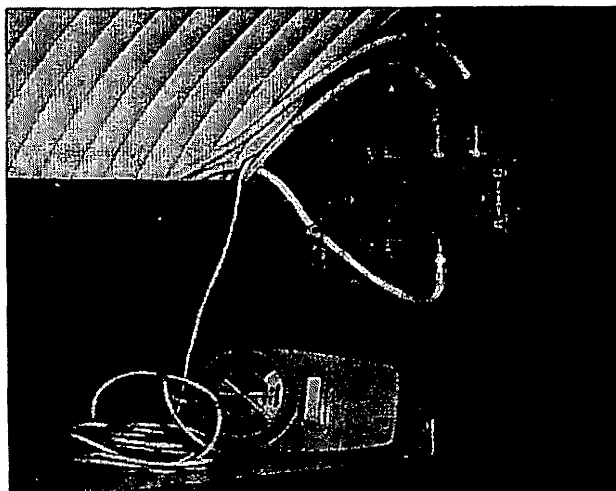

Figure 3-20. Antenna Rotator



SECTION IV

ELECTRICAL SYSTEMS

INTRODUCTION

There are actually two interrelated electrical systems used in your motorhome: the 12-volt dc supply system; and the 120-volt ac supply system. The 12-volt dc supply system is divided into two branches, each functioning from a common 12-volt battery source. One branch provides the 12 volts required for the automotive starting, ignition, and charging systems; the other branch supplies 12 volts to those motorhome appliances which require 12 volts for operation.

The 120-volt ac system includes those motorhome appliances which require 120 volts for their operation, supplied either from the internal generator plant; or from the external 120-volt ac (or a split 240-volt ac) supply, via the shoreline hookup.

12-VOLT DC SUPPLY SYSTEM

The 12-volt dc supply is furnished to the standard automotive starting, ignition and charging system; and to the motorhome distribution circuits. A degree of interface exists between these systems in that the motorhome distribution circuits also

provide some circuit breaker protection for certain automotive lighting functions. Each of these circuits relies on the 12 volts provided from the four series-parallel connected 6-volt batteries located in the compartment on the left side of the coach. An overall wiring diagram of the 12-volt supply and distribution system is included in Section X.

MOTORHOME 12-VOLT CIRCUITS

The 12 volts supplied to all motorhome appliances, outlets and accessories is routed from the batteries through a 12-volt bus and individual circuit breakers. The circuit breakers are located behind the access panel at the front left side of the coach. In addition to the inline circuit breakers (for auto air conditioners) and fuses located in the battery compartment, two major sets of circuit breakers are used to protect 12 volt circuits. Table 4-1 lists circuit breakers for chassis wiring; table 4-2 lists circuit breakers for body wiring; table 4-3 lists in-line circuit breakers; and table 4-4 lists fuses. Refer to figure 4-1 for location of circuit breakers within the outer access panel; refer to figure 4-2 for identification of fuses in the battery compartment.

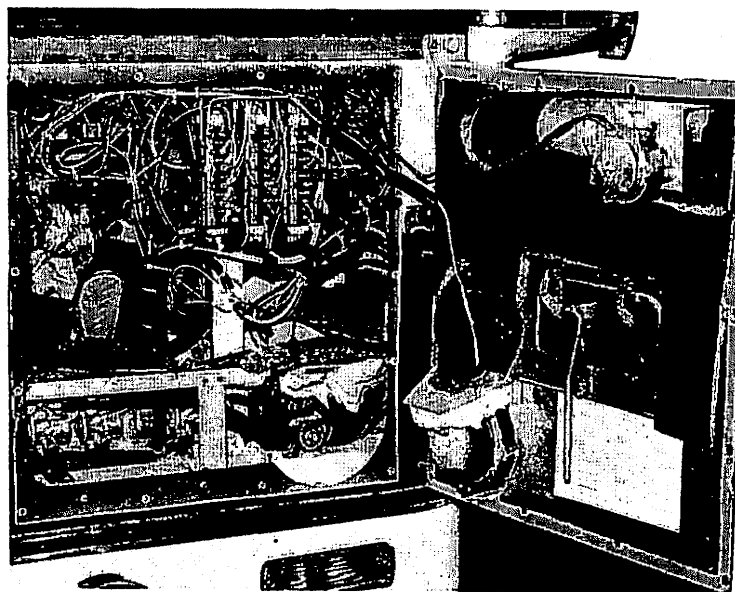

Figure 4-1. Circuit Breaker Panels (12 Volt DC)



Table 4-1. Circuit Breakers for Chassis Wiring(12v)

Rating	Protects
20A	Brake limit switch
20A	Directional light switch
20A	Dashboard cigarette lighter
20A	Musical horns
20A	Air horns solenoid
10A	Spotlight; Fog lights solenoid
20A	Backup lights (via ignition switch)
20A	Ignition solenoid; air step light on dash
20A	Low air buzzer; cruise control pumps; water-in-fuel indicator; low fuel indicator
20A	Safeline warning buzzer (via shoreline contactor and safeline switch; water pump
15A	Leveling jack lights; leveling jack warning buzzer
6A	Cruise control regulator
30A	Front landing lights
30A	Rear landing lights
20A	Compartment lights
15A	Leveling jacks
—	Spare
30A	Fog lights

Table 4-2. Circuit Breakers for Body Wiring (12v)

Rating	Protects
20A	Engine heaters (3)
20A	Windshield washer motor
20A	Defroster blower motor
20A	Wiper motors (2); front left side heater
20A	Front right side heater
20A	Toilet exhaust light, fan; toilet lighting fluorescents (2); reading lights (2)
20A	Spare
20A	Marker lights
20A	Closet lights; bedroom fluorescents (4)
20A	Reading lights (5); 12-volt receptacles (4); switched aisle light
20A	Living room fluorescents (7)

20A	Entrance light (ext.); airstep; aisle fluorescents (2); stepwell fluorescent; reading light; bed room fluorescent
20A	Air step; aisle lights (3)
20A	Main exhaust fans (2); furnace thermostats (3); toilet

Table 4-3. Circuit Breakers (12V)

Rating	Protects
30A	Chassis air conditioner switches
30A	Chassis air conditioner condenser

Table 4-4. Battery Compartment Fuses (12v)

Rating	Protects
2A	CB transceiver memory bank
2A	Digital clock
2A	Burglar alarm

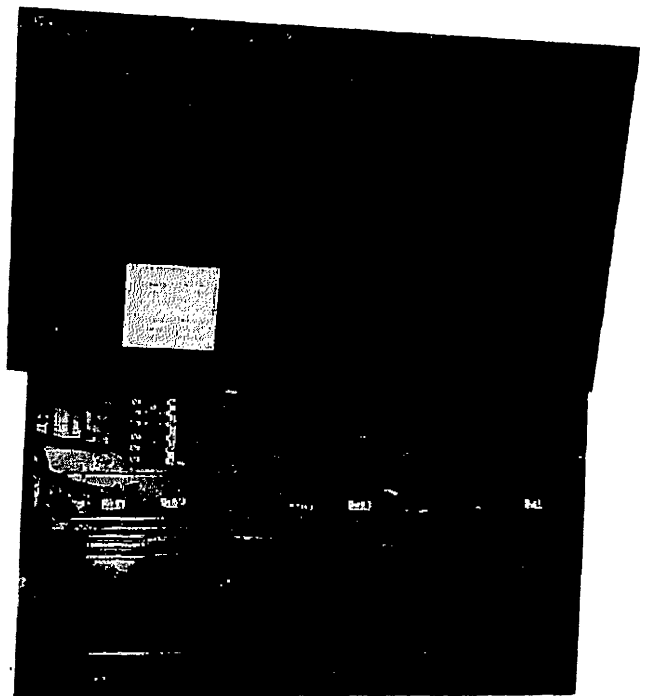

Figure 4-2. Fuse Panel



BATTERY CHARGER

The 12-volt batteries are maintained in a fully-charged condition by either the engine alternator (when the engine is operating); or by two 45-ampere battery chargers. These automatic electronic battery chargers, located in the left side mid-mount storage compartment, figure 4-3, operate whenever a source of 120-volts ac is supplied to the coach circuits (either shoreline or generator operation). When the battery chargers are operating, the batteries are effectively placed off-load, and charged, while the battery chargers supply 12 volts dc to the motorhome circuits. This makes it possible to use all 12-volt systems while still charging the storage batteries. The two chargers ensure rapid recharging of the main batteries and furnish a total of 90 amperes of service to the coach.

NOTE

When using battery power only for operation of heavy-load circuits, such as lighting, motors and furnace, check battery condition periodically to prevent batteries discharging. If battery condition is marginal, operate generator plant to keep batteries charged.

DC SUPPLY MONITORS

There are various locations within the coach where the condition and current drain of the 12-volt dc supply may be observed. For example, the compartment just inside and to the left of the step-well contains a center-reading $-100-0+100$ ammeter which shows battery charging (+) or discharging (-) current. A digital voltmeter, on the status panel located on the galley side wall, provides a digital readout of the battery voltage. In addition, the driver's dashboard instrumentation includes a voltmeter and ammeter for monitoring battery condition during on-road operation. Because battery condition is so vital to the proper operation of 12-volt motorhome appliances, use these meter readings to be constantly aware of the battery status to avert possible inconvenience or battery/component damage.

AC SUPPLY SYSTEM

The motorhome ac-operated appliances are supplied from either an external shoreline hookup; or from the internal generator plant. Selection of which power source is to be used is determined by a four-position ac power selector switch located in

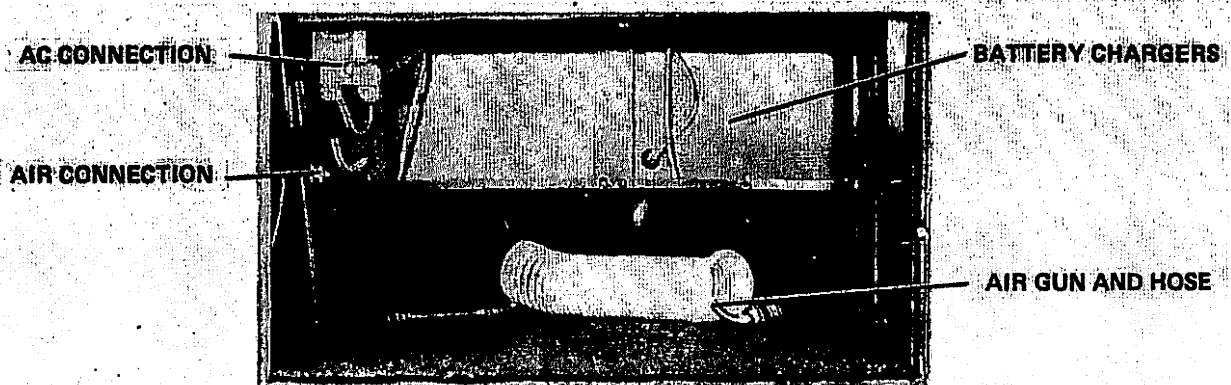

Figure 4-3. Location of Battery Chargers



a compartment just inside and to the left of the stepwell, as shown in figure 4-4. Set this switch to either GEN, SHORE 50A, SHORE 30A or OFF, depending on the power source availability. Leave this switch OFF to completely disconnect the motorhome 120-volt ac circuits.

The generator can be started and stopped from either of two locations within the coach: at the driver's instrument panel; or at the galley wall monitor switch panel. In addition, the generator can also be started at the remote panel located in the generator compartment.

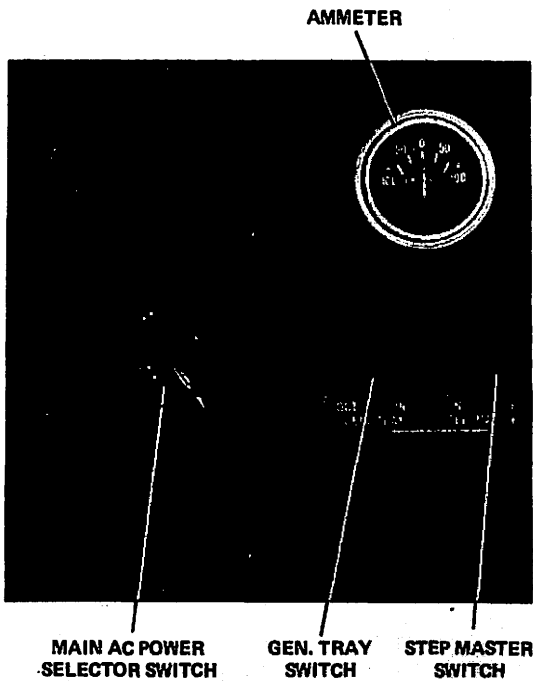

Figure 4-4. Ac Power Selector Switch

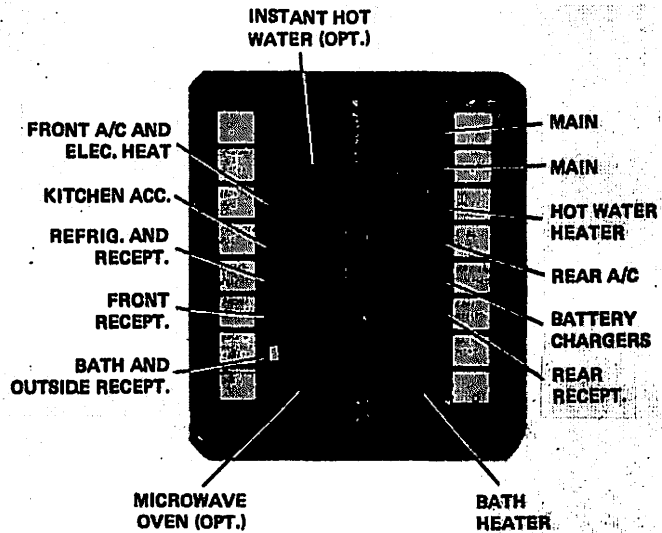

Figure 4-5. Load Center Circuit Breakers

POWER LINE MONITORS

Two power line monitors are located on the galley wall to monitor the ac shoreline supply (or generator supply) voltage. If the shoreline is "split", one monitor is connected to each side. Each monitor has polarity and ground detector circuits to indicate possible electrical hazards due to incorrect hookups.

AC CIRCUIT BREAKER PANELS

Two main ac circuit breaker panels are located within the rear closet. Refer to figures 4-5 and 4-6 for identification and location of load center and over-current circuit breakers, respectively.

GENERATOR OPERATION

The generator plant has its own 12-volt starting battery so that it can operate independently of the coach 12-volt batteries and can be started even if the motorhome batteries are discharged.

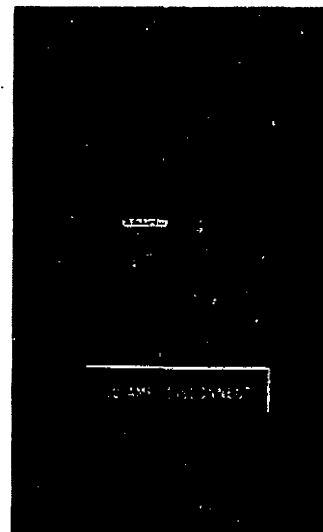

Figure 4-6. Over-Current Circuit Breakers



To start the generator, push the GENERATOR switch forward to the ON position and hold until the generator starts, as indicated by the generator ON indicator lighting. **DO NOT HOLD SWITCH ON FOR LONGER THAN 15 SECONDS AT A TIME!** If the generator does not start the first time, wait a minute and try again. Release the switch when the ON lamp glows.

To start the generator directly at the generator compartment, figure 4-7, use REMOTE START switch located on the control box. The generator may be stopped at any time, from either of the three locations, by holding the switch down to the STOP position until the generator stops (light in switch extinguishes).

It is not advisable to start the generator under a heavy load, especially with the high current demands made by the air conditioners. This may cause hard starting and possible damage to the generator electrical system. It is a good practice to remember to set the MAIN SELECTOR switch to OFF (figure 4-4) before turning on the generator so there will be no electrical load on the line. Also, remember to set the selector switch to GEN position when the generator is being used; and to reset the switch to either OFF or to SHORE position, as appropriate.

The generator is housed within an air-operated extendable tray, shown in the opened position in figure 4-7. The tray is normally locked into place by a hand-latch located underside. To open, unlock the latch and extend the tray outward by operating the OUT-IN GEN. TRAY switch in the stepwell compartment. Note that the tray is air-operated via an electrical solenoid and that the air pressure must be up for tray operation.

CAUTION

The generator tray is **HEAVY** and moves in and out with a great deal of force. **KEEP HANDS OFF TRAY WHEN OPERATING SWITCH!**

AC SHORELINE OPERATION (COMMERCIAL POWER)

Set the power selector switch, figure 4-4, to the

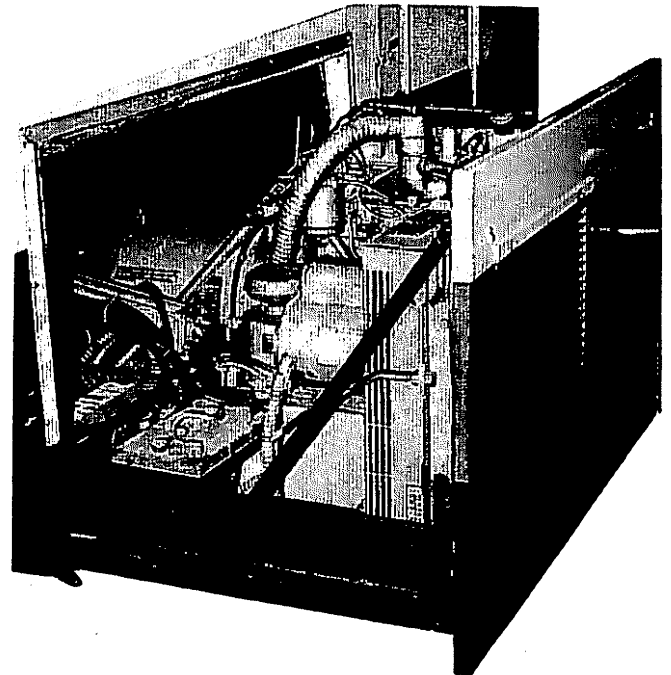

Figure 4-7. Generator Compartment Extended

proper SHORE position **BEFORE** connecting the motorhome electrical system to the external ac supply. For purposes of safety, observe all precautions when connecting the shoreline. Poor grounding, or incorrectly-wired receptacles can cause personal harm as well as equipment damage or fire hazards. Check power line monitors on galley side wall to ensure proper supply voltage, polarity and grounding of line connections.

NOTE

Your motorhome has been wired in accordance with the National Electrical Code. All 120-volt ac wiring is two-wire service with ground; all 220-volt wiring is three-wire service with ground. If the motorhome is connected to an external hookup which has only a two-wire circuit, ground the third wire on the adapter to the external supply metal junction box or conduit. Utilize the polarity detector indicators on the power line monitors to be sure that lines are properly connected and grounded.

For commercial power (120 v ac), the coach is equipped with a 25-foot 12-3 shore line; for 220 volts ac, a heavier 8-3 cable is used.



Before completing the shoreline hookup, shut off the ac appliances and set the power selector switch to the appropriate SHORE position. Connect the shoreline, stored in the compartment shown in figure 4-8, between the external power source and the coach shoreline receptacle. (The coach receptacles are located in the same compartment as the water hookups, in the rear next to the left side tail light, figure 5-1.)

In many instances, the shoreline hookups will not be rated to operate all electrical appliances in your coach. Check with facility personnel to determine the maximum current capability of the hookup. Usually, only one air conditioner or electrical hot water heater may be operated at a time. The current ratings for appliances designated for standard or optional (identified by *) usage in your coach are listed in table 4-5.

Table 4-5. Electrical Ratings for Motorhome Appliances

Item	Current Rating (Amperes)
Air Conditioners	
13,500 BTU	17.5
Hot Water Heater	10.0
Television Receivers	
Black-and-white	.5
Color	1.0

Battery Chargers (depends on battery condition/load)	0 to 12.0
Engine Block Heater	10.0
Bathroom Heater	--
*Electric Heaters	
Cheater	12.5
Squirrel Cage	
*Auxiliary Generator(Redi-Line)	
600W	--
1600W	--
*2 cu. ft. Refrigerator/Freezer	--
*Microwave Oven	15.0
Food Center	4.0
Vacuum Cleaner System	9.0
Refrigerator (Dometic)	2.5
*Ice Maker	2.5
*Washing Machine/Dryer	25.0
*Instant Hot Water	--
*110v AM/FM Radio	--

SAFELINE ALARM

Your coach is equipped with a shoreline disconnect alarm, located on the right side of the dashboard, figure 2-14. This device will provide an audible or visual alarm whenever the shoreline is left connected to the coach at the same time that the 12 volts dc coach supply is also present. This will assure that the coach is not inadvertently driven away while still connected to the shoreline hookup.

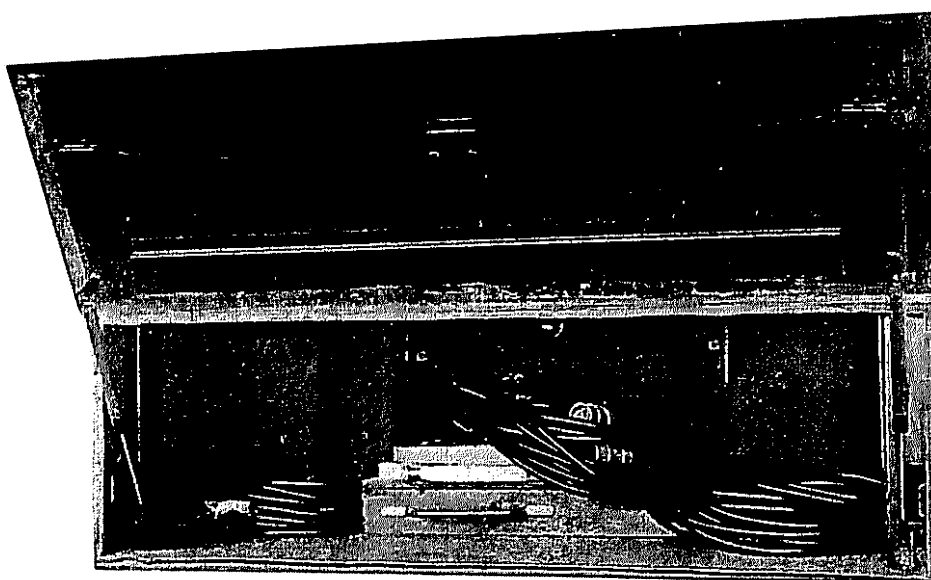

Figure 4-8. Shoreline Hookups (Storage Compartment)



SECTION V

WATER DISTRIBUTION SYSTEMS

INTRODUCTION

The motorhome is equipped with a completely self-contained water system which has piping, heating, and drainage facilities similar to that found in standard home installations. The water supply and distribution system includes three networks: (1) a potable water supply system, which includes the water tank, pump, air accumulators, pressure switch and supply lines; (2) water heater and interior hot water heating systems; and (3) waste, winterizing, quick drain and sewage drainage systems. Refer to Section X for water system piping diagrams.

WATER SUPPLY AND DISTRIBUTION SYSTEM

As shown in figure 5-1, the water fill and commercial water connections are located in the utility compartment at the left rear side of the coach, which also contains the shoreline hookups. The plastic pure water storage tank, located beneath the left rear bed, is a non-pressurized type of tank, which means that system water pressure is developed by pumping action directly into the supply lines, rather than applying air pressure to the tank.

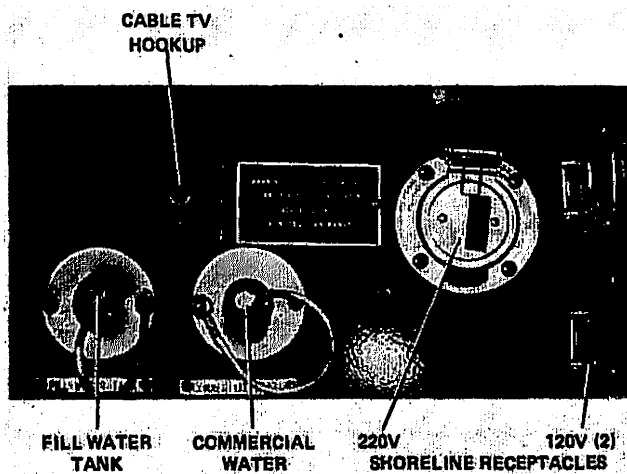

Figure 5-1. Location of Water Fill and Commercial Water Hookups

COMMERCIAL WATER HOOKUP

When facilities are available, use the **COMMERCIAL WATER** hookup to meet the water system supply requirements. By attaching the connection directly to this inlet, the motorhome water tank and pump system is bypassed and the supply line water pressure is developed by the external connection. A check valve, connected in series with the water supply inlet, automatically bypasses the pump and tank, making pump operation unnecessary. A 45-pound reducing valve is also in-line (located near the water heater).

FILLING AND SANITIZING THE WATER SUPPLY SYSTEM

FILLING THE TANK — To fill the water tank, insert the end of a sanitary (“white”) hose into the **FILL WATER** inlet and turn on the water supply. A filled tank will be indicated by water overflow under the coach. At this time, operation of The Monitor panel (galley side wall) can be checked and adjusted, if necessary. Refer to figure 3-14, set power ON-OFF switch ON, depress **PURE** tank switch and verify that digital readout is 100 (percent). Adjustments of the digital readout can be made with a small screwdriver to set the trimmer through the access hole beneath the **PURE** button.

SANITIZING THE WATER SYSTEM — Since the only source of potable water in the motorhome is contained in the supply tank, it is extremely important that this water supply be as free as possible of impurities and contamination. Accordingly, water tank sanitizing procedures should be followed before the tank is filled for the first time; after long idle periods, where water may become stagnant; or after any suspected contamination of the water supply. Whenever possible, use a commercially-approved tank sanitizer and follow the procedures on the product package. If it is not possible to use a commercial product, prepare your own mixture and sanitize the tank in accordance with the following procedures:

1. Empty the Water Tank — To drain the entire



water system open six drain valves listed below (and shown in the water system piping diagram in Section X):

- a. Quick-drain valve in compartment in side of left-hand bed base.
- b. Tank drain valve, at end of tank, beneath left-side bed.
- c. Drain valve in water line behind check valve near water tank.
- d. Hot and cold water drain valves, located beneath the bathroom cabinet, figure 5-2.
- e. Hot water tank drain valve.

NOTE

If it is necessary to drain only the tank, just open the tank drain valve and several faucets.

If a complete system drainage is required, such as that normally performed before placing the motorhome in cold-weather storage, open all valves, install a blow-out plug on the COMMERCIAL WATER connection and blow out the system with compressed air. (Compressed air source is available in left side middle compartment, figure 4-3.) Be sure to close the valves after draining is completed.

2. Prepare the Sanitizing Mixture — Prepare a concentrated sodium hypochlorite solution from a mixture of water and household bleach (Clorox, for example, 5½ to 6% solution). The proportions are ¼ cup bleach to one gallon of water.

3. Add Sanitizing Mixture to Water Tank — Using the prepared sanitizing mixture, pour into the tank one gallon of mixture for each 15 gallons of tank capacity. Since the water tank will hold about 96 gallons, 6-1/2 gallons of the mixture will be required for a thorough sanitizing of the tank.

4. Fill tank to Capacity — Connect the hose to FILL WATER inlet and fill the water tank completely. Remove hose, close FILL WATER connection and allow the system to stand for several hours.

5. Drain System — Open several faucets, open drains previously listed and allow the system to

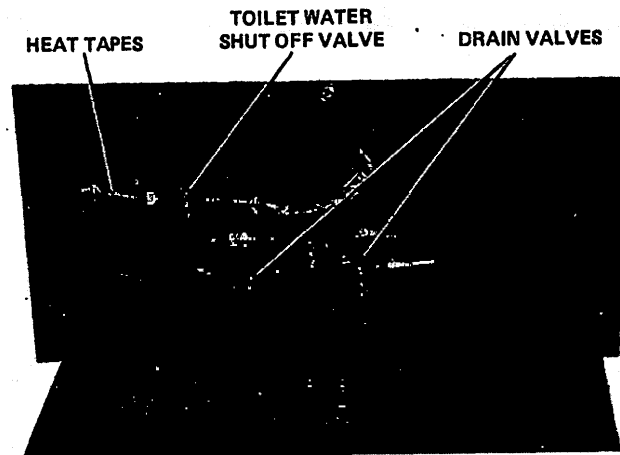

Figure 5-2. Under-Sink Plumbing

drain completely.

6. Refill System with Potable Water — Close all drain valves, connect white hose and fill system completely. When tank is full, disconnect hose, replace fill cap and turn on water pump. When water flows from the opened faucets, close them and open other faucets until water flows. This flushes out the system, removes trapped air from the piping and ensures that the fresh water supply is ready for use.

NOTE

Residual water tastes or odors can be removed by again draining and rinsing the system with a vinegar solution mixed to the ratio of one quart of vinegar to five gallons of water.

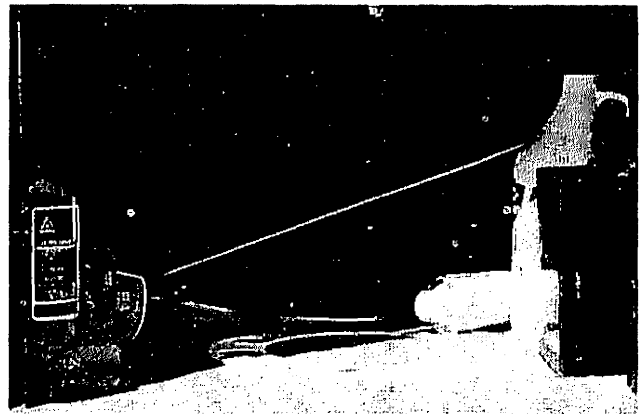

Figure 5-3. Front Right Side Compartment



POTABLE WATER DISTRIBUTION SYSTEM

The major components of the potable water distribution system, shown in Section X, are the water tank, pump guard (inlet filter), water pump, air accumulators, hot water heater, piping and fixtures. In addition, a water purifier filter is connected in the cold water supply line to the galley sink and the ice-maker (optional item). Note that the heating coils in the hot water heater are also a part of the heat exchanger loop for the engine coolant system, shown in the heater piping diagram in Section X.

For side-bath models, the hot and cold water piping is routed first to the galley sink, then to the shower, bathroom sink and the toilet. (For rear-bath models, the hot and cold water piping is routed first to the toilet water supply shut-off valve located beneath the sink.) Note that the drain valves are also located beneath the sink, as shown in figure 5-2. These valves are used only when it is necessary to drain out the lines prior to winterizing the unit; or for draining the system completely for sanitizing. Keep valves closed at all other times.

The water pump is equipped with a factory-calibrated pressure control switch which is preset to turn the pump on when the system pressure falls below 25 psi; and turn the pump off when the pressure reaches 35 psi. If the pump has been out of service for a period of time, it is advisable to open a faucet before turning the pump on. This will allow for easier starting by reducing the pump starting load. When water flows steadily from the opened faucet, close faucet and observe that pump shuts off when system becomes pressurized. (It may also be necessary to bleed the air from the other faucets as well.) When the potable water supply tank level is low, or empty, shut the pump off to prevent possible damage to the pump motor. In addition to integral motor overload protection, the pump mechanism is also protected from jamming by the presence of an inline filter (pump guard) between the pump and the supply tank.

FILTER CARTRIDGE REPLACEMENT — It is advisable to replace the filter cartridge (optional) in the water purifier periodically (at least once every six months) to prevent reduction in water pressure due to clogging of the filter element. Replace filter sooner if clogging is apparent and tap

water flow is noticeably reduced. To change the filter cartridge, figure 5-4, proceed as follows:

1. Turn off master valve (in front of filter) and depress pressure release button to relieve pressure in housing. Be sure to shut off water pump.

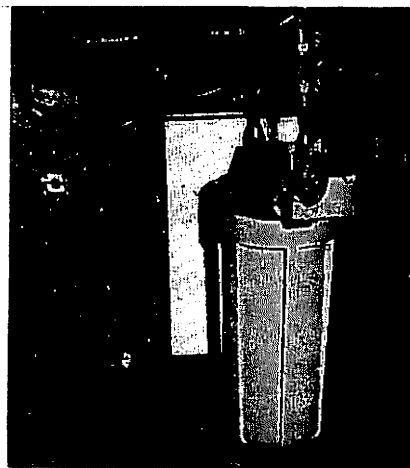

Figure 5-4. Filter Cartridge

2. Unscrew housing from cap, discard old cartridge and insert a new cartridge.

3. It is important for proper operation of the filter that the O-ring gasket be seated correctly in the groove. Wipe the old lubricant from the O-ring and re-lubricate with a light coating of clear petroleum jelly (Vaseline). Place the O-ring in the groove and, pressing down firmly with two fingers, wipe the O-ring down into the groove so that it is level and flat.

4. Screw the housing onto the cap and hand-tighten securely. Open the master water inlet valve one-quarter turn and depress the pressure release button. When all air has escaped from the system fully open the master valve and turn on the water pump. Note that an activated carbon cartridge will contain a very small amount of carbon "fines" (very fine black powder particles) and a new cartridge should be flushed with sufficient water, after installation, to remove all traces of fines from the water system before drinking the water.

Each time you use the water from your filtered water tap for drinking or cooking purposes, it is recommended that you run (flush) the tap for at least ten seconds to clean out the line prior to using the water. This is particularly important if the water tap is not used daily.



HOT WATER HEATER

The hot-water heater is a fibreglas-jacketed coil-type heat exchanger which ensures a continuous supply of hot water through heat exchanger action with the automotive coolant system and auxiliary pump. When the engine is off, the hot water heater can still supply hot water through the use of an electrical heater. The electrical heater is on all the time that the ac supply is available. The electric heater circuit breaker, located in the circuit breaker panel in the rear closet, should be switched OFF when heated water is not needed; or, use the ON-OFF pilot light/switch located in the side of the rear left bed base. For electrical operation, a source of 120 volts ac must be available, either from the shore line, or from the internal generator plant.

PLUMBING AND DRAINAGE SYSTEM

A diagram of the plumbing and drainage system is provided in Section X. Separate holding tanks for gray water (42 gallons) and waste (60 gallons) are located beneath the coach mid-section. In side-bath units, the gray water holding tank is closer to the rear of the coach and is the receiver for the gray water from the kitchen sink and the shower. The waste holding tank, located toward the front of the unit, stores toilet wastes and waste water from the bathroom sink. In rear-bath models, the 42-gallon holding tank is located in the right rear; and the 60 gallon holding tank is located in the left rear. Each holding tank has a separate drain valve, dumping gray water and wastes through a common single discharge connection. A common

wet vent system connects both holding tanks to the vent stack located on the coach roof.

DRAINING THE HOLDING TANKS

The holding tanks drain valves are located under the left side of the coach, as shown in figure 5-5. The waste drain valve is on the right side, near the drain cap; and the gray water drain valve is on the left side, near the wheel. Each drain valve operates in the same manner. Drain the holding tanks as follows:

1. Check that both drain valves are in closed position before proceeding any further. Note that the valve handles will be turned clockwise to close the valve.
2. Drain the waste holding tank first.
3. Remove the safety cap from the single discharge connection by turning the locking ring in a counter-clockwise direction and connect the 3-inch sewer hose coupling to the end of the valve. Tighten locking ring securely, in a clockwise direction. The sewer hose is stored within a pipe located to the right of the drain cap, on side-bath units; and under the bottom skirt panel, left rear, on rear-bath models. Place the discharge end of the hose into the sewer connection and check that all connections are secure to prevent accidental spillage.
4. Open the drain valve by turning the handle to the left (counter-clockwise), then pull the valve stem straight outward. This will discharge the holding tank contents into the sewer connection.

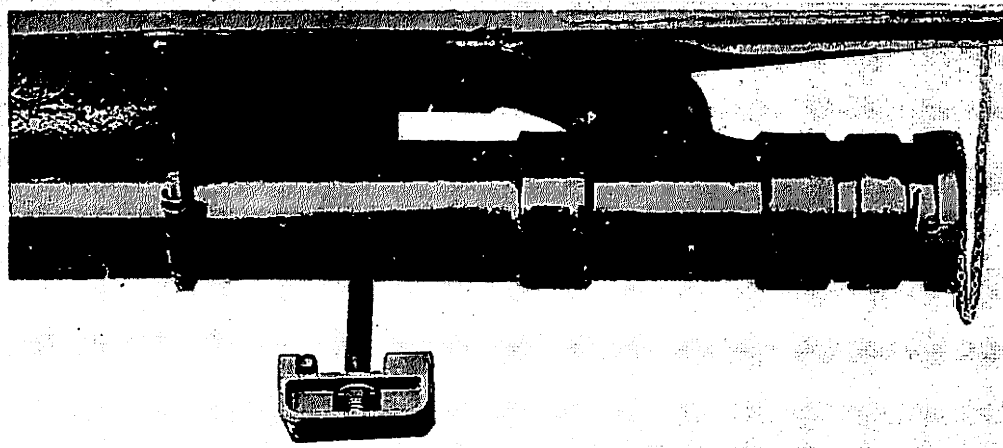

Figure 5-5. Location of Holding Tanks Drain Valves



5. Periodically, after contents are emptied, flush out holding tank to dislodge remaining solids. [Connect a water hose to the "swisher" connection (water saver hose connection adjoining the toilet) and turn on the water supply. A check valve keeps contents from running back into water hose.]

NOTE

To clean the holding tank, add a cup of detergent into the tank after it is emptied. The agitating action from vehicle movement will clean the tank.

6. Close drain valve by pushing valve inward and turning handle to the right (clockwise) into the locked position.

7. Drain gray water holding tank in the same manner, following steps 4, 5, and 6, as applicable.

8. Disconnect and wash out drain hose and replace safety cap securely.

TANK LEVEL DETECTORS

Each of the holding tanks, and the potable water supply tank, is equipped with a level detector which provides an electrical input to The Monitor panel on the side galley wall, figure 3-14. The amount of liquid remaining in each tank is indicated on the panel in terms of %. To read the level of the material in a tank, set power ON-OFF switch (on The Clock) to ON, depress the button for the respective tank, and read the digital display.

WINTERIZING

If the motorhome is to be stored outside during cold weather, it will be necessary to winterize the water system to prevent damage from freezing conditions. To prevent freezing of water pipe supply lines, pipes are wrapped with a heat-tape that operates automatically when the temperature drops below 38 degrees F, providing that the coach is connected to the ac supply. Check that the tape is connected to the receptacle in the rear of the refrigerator compartment.

The following paragraphs describe the steps to be taken to ensure that your coach can withstand sub-freezing temperatures without harm.

DRAINING THE FRESH WATER SYSTEM

Drain the fresh water system by opening all faucets and drain valves, using the same procedures as that previously described for sanitizing. To summarize:

1. Open all faucets, valves and drains.
2. Leave drains open.
3. Block toilet bowl seal valve in the open position (if mechanical-seal type) with an object that will not fall into the holding tank.
4. Turn water pump switch ON, allow pump to run dry for a few minutes and then turn switch to OFF position. (Pump may turn off automatically when line is dry, then shut off power.)
5. Remove filter cartridge from water filter, if included, and drain lower portion of housing.
6. As an added precaution, after water has stopped draining, and with valves and faucets still open, air pressure can be applied to the commercial water connection to blow out any remaining water that may be trapped in the lines.

CAUTION

When adding anti-freeze solution to the water system for more positive protection, be sure that it is a type approved for potable water systems. **DO NOT USE AUTOMOTIVE ANTI-FREEZE!**

7. Leave all faucets and valves closed during storage. Before restoring the coach to service, be sure to sanitize the water system in accordance with the instructions previously described in this section.

PREPARING DRAINAGE SYSTEM FOR STORAGE

The entire drainage system should be thoroughly drained and flushed with fresh water. The following procedures are recommended:

1. Completely drain holding tanks of waste material.
2. Flush sinks, shower and lavatory with a solution of hot water, water softener and soap. Rinse well and allow solution to drain into tanks. Flush with clean water.



3. Agitate water in tank by rocking vehicle or, for a more thorough cleaning, drive vehicle for a few miles. Drain tanks again.

4. Alternatively, use a chemical deodorant, let mixture stand a few days, and then drain.

5. Flush with fresh water and again drain.

6. Fill traps and partially fill tanks with an anti-freeze approved for use in plastic pipes. Normally, a cupful of anti-freeze poured into each drain will fill the trap. Do not use anti-freeze solution with an alcohol base!

BATTERY STORAGE IN FREEZING WEATHER

Batteries that are not kept fully-charged must be given protection against freezing. Partially-charged batteries will freeze at low temperatures, so batteries must either be left connected to a trickle charger or removed from the vehicle and stored in a warm location. Note that even in a warm loca-

tion, it is advisable to keep the batteries charged so that they are ready for use. Add water as required.

NOTE

Remove all items from the coach which may freeze, including canned foods, miscellaneous liquids, etc. Remove all contents of the refrigerator/freezer, clean the unit and leave doors ajar.

GENERAL STORAGE NOTES

Drawing draperies will reduce fading of rugs and upholstery. Leaving an air freshener agent will minimize odors from plastics and other materials. Slight opening of windows and vents will allow air circulation without worry of water entering. Covering wheels to eliminate direct rays of the sun on tires will reduce sidewall cracking.



SECTION VI

LPG SYSTEM

INTRODUCTION

The coach is equipped with a permanently-mounted LPG (Liquified Petroleum Gas) tank which is the energy source for operation of the refrigerator, range/oven and three gas furnaces. A piping diagram of the complete LPG system is shown in Section X.

LPG TANK

The LPG supply is stored in a tank located in the compartment forward of the entry door (which also encloses the Racor diesel fuel filter/preheater). The capacity of the LPG tank is 44.5 gallons, equal to 150 pounds of fuel. Controls on the tank, shown in figure 6-1, include the main gas valve, high-pressure regulator, filler connection and a 20% relief valve which provides 312 PSI protection. The low-pressure regulator is located in the refrigerator compartment and connects with the tank via a flexible high-pressure hose. Tank level (in percent) can be checked at The Monitor panel on the galley wall, figure 3-14. To read the digital display on the panel, set POWER ON-OFF switch (on The Clock) to ON position, then press the PROPANE TANK button.

CAUTION

Be sure to shut off all gas appliances before filling the LPG tank. Check gas lines and fittings periodically for tightness and leakage.

FUEL REQUIREMENTS

Liquified petroleum gas is a material composed of various hydrocarbons such as propane, propylene, butane, butylene, or a mixture thereof. In its gaseous form (vaporized) it is colorless and has a garlic-scented additive to ensure detection. In addition to being highly inflammable, it is also dangerous to inhale. For ease of transportation and storage, LPG is compressed into a liquid state and stored, in this form, within the LPG tank. As fuel is used, vapor passes from the top of the tank, via the high-pressure regulator, to the low-pressure regulator, which reduces the LPG pressure to about 6-1/6 PSI. Low-pressure vapor is then supplied through LPG piping to the various gas appliances.

Moisture condensation within the tank and line, with possible cold-weather freeze-ups, can be prevented when filling the tank by requesting

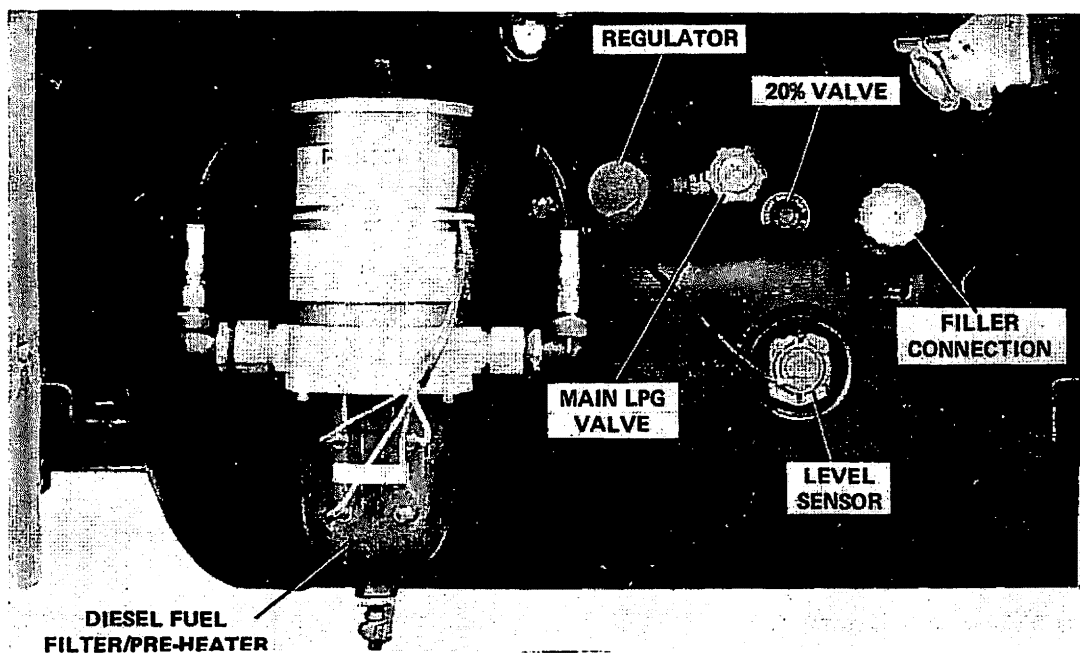

Figure 6-1. Location of LPG Tank and Controls



the dealer to add a small amount of Methyl Alcohol to the fill-up. A common mixture is one ounce of Methyl Alcohol to each 20 pounds of LPG. Note that the dealer must use a P.O.L. adapter when filling the tank. A filled tank is indicated when liquid appears at the 20% valve.

LIFEGUARD ONE

Gas and vapor sensors located near coach gas appliances continuously monitor the air for LPG contamination and sound an alarm if the safe amount of LPG in air is exceeded. Lifeguard One, which performs this vital function, is located on the wall behind the dinette, as shown in figure 3-17.

LPG REGULATOR

The low-pressure regulator, located in the refrigerator compartment, regulates the pressure of the LPG supplied to the appliances. The regulator functions automatically and is factory-preset to provide the correct line pressure. **DO NOT** attempt to tamper with or reset the regulator! Even a small variation above the normal gas line pressure can be sufficient to create a dangerous situation and cause possible damage to individual appliance regulators. The high-pressure regulator is located on the LPG tank.

OPERATION

Before the main valve on the LPG tank is opened, check that all inside local shutoff valves are closed. These valves are located at the inlet to each of the gas appliances.

CHECKING FOR LEAKS

Periodically check the LPG system for possible leakage. Do not wait for an alarm condition to occur before correcting a leak! Although the entire system and associated appliances undergo extensive factory testing for leakage, road shocks and heavy vibrations may loosen or damage piping or fittings. Leaks will usually become noticeable by the smell of the characteristic odor-additive of garlic (or onions). If you smell this odor, or if Lifeguard One sounds an alarm, immediately turn

off all flames and begin a systematic search for the leak throughout the entire gas system, or at the monitor point indicated by Lifeguard One. Use a bubble or soap solution and brush on connections and fittings.

CAUTION

**NEVER BRING A LIT MATCH
NEAR A SUSPECTED LEAK!**

Gas leakage will be indicated by the presence of bubbles at junctions or at piping breaks. If it is necessary to tighten a gas connection, turn off the LPG main tank valve, then use two wrenches on the connection, with opposing torques to prevent twisting or distortion of the copper tubing. If the leak cannot be found in this manner, the appliance itself may be at fault. Shut down the suspected appliance to isolate it from the system until repairs can be made by an authorized service station.

LPG CONSUMPTION

Most gas appliances are intermittently operated. However, operation during cold weather conditions does cause a heavy use of the gas furnaces. Extensive oven usage also consumes a great deal of fuel. The amount of LPG consumption depends on the total use and manner of use of these appliances.

Note that each gallon (4-1/4 lbs) of LPG fuel produces approximately 91,500 BTU's of heat energy. The LPG tank used in your coach will furnish about 4 million BTU's.

For your guidance in estimating your anticipated fuel consumption, the following is a listing of typical appliance consumption ratings when the appliance is operated for one hour:

Refrigerator	1,500 BTU's
Furnace (each)	30,000 BTU's
Range Oven	10,000 BTU's
Range Top Burners	5,200 BTU's
Furnaces:	
Bedroom	16,000 BTU's
Living Room (front)	16,000 BTU's
Living Room (middle)	12,000 BTU's



SECTION VII

AIR BRAKE SYSTEMS

INTRODUCTION

Your motorhome is equipped with dual service air brake systems, with integral fail/safe operation; and manual/automatic rear spring (parking) brakes. As shown in the air brakes system diagram in Section X, the service brakes are completely independent systems, each including a reservoir and separate distribution lines and valves. A separate reservoir is also supplied for the rear spring brakes, which function independently of the service brakes. All three reservoirs are pressurized from a single compressor. Both service brake systems are brought into operation each time the brake treadle is depressed to slow or stop the coach. Reservoir pressure for each service brake system is monitored by a respective pressure gauge on the front panel; system failure(s) are indicated by low pressure readings, illumination of the LOW AIR failure lamp, located above the odometer, and by sounding of the low air warning buzzer.

OPERATION

When the coach is parked, and the engine off, the rear spring brakes will normally be set by operating the parking brake. The spring brakes cannot be fully released until the air pressure is above 90 psi. These brakes are in the released position when the control is pulled out. In the event that there is a loss of air pressure, the spring brakes will set automatically, at the brake-applied position, and will not release until the air reserve has again built up to the required value. Consequently, there will be a normal delay, after the coach is first started, before the compressor builds up sufficient pressure in the three reservoir tanks, before the brakes can be released and the coach driven. When the brake treadle is depressed, to slow or stop the coach, reservoir air is applied simultaneously to both front and rear service brakes to effect the braking action. The spring brakes are held in a released position by the air pressure supplied from the associated reservoir tank.

CAUTION

Do not attempt to drive the coach until system pressure is 90 to 105 psi.

BRAKE FAILURES

Brake system failures are protected against by a combination of fail/safe features. Each service braking system, front and rear, has a backup capability in the form of the rear spring brakes in the event of partial or total system failures. If the front brakes fail, operating the brake treadle activates both the rear service brakes and the rear spring brakes, providing sufficient braking action to effectively stop the coach. Under these conditions, the spring brakes do not lock in, as in a normal released position, but instead their application is "modulated" in the same manner as the service brakes, thereby providing a normal braking "feel". If a failure occurs in the rear, the front and rear spring brakes provide braking action.

In the unlikely event of a failure where both service braking systems are disabled, the rear spring brakes will apply automatically and bring the vehicle to a stop. As a safety factor, the coach should not be moved until any type of brake failures are corrected.

NOTE

With the front brake system service reservoir fully charged, enough air pressure is available to provide for four full releases of the rear spring brakes. This will allow the coach to be brought to a safe position until repairs can be accomplished.

MISCELLANEOUS AIR—OPERATED EQUIPMENT

In addition to supplying the compressed air supply for the coach braking systems, the compressor also furnishes 60 psi air to the entry step, gene-



rator tray, and steering wheel tilt mechanism — all via separately-controlled solenoid switches operated from the dashboard, or at other locations throughout the coach. (This compressed air source is furnished from the front right side reservoir.) For example, the compartment located

just inside the entry door contains switches for the generator tray and entry door step (also controlled at the dashboard). Also, a compressed air outlet fitting and air gun is contained in the center storage compartment on the left side of the coach, figure 4-3, convenient for blowing out the water system, inflating tires, and so on.



SECTION VIII

OWNER MAINTENANCE DATA

INTRODUCTION

This section provides general information for use in performing scheduled services as well as preventive and routine maintenance on your motorhome.

SPECIFICATIONS AND DATA

Table 8-1.

Engine Capacities and Specifications

Item	Specifications
Fuel Tank Capacity	150 gallons
Fuel Type	Diesel fuel
Cooling System Capacity	
w/front heater	46 quarts
w/front and rear heaters	60.2 quarts
Crankcase Capacity	
Dry	12 quarts
Refill	10.5 quarts
Oil Specifications	MS, Series 3
Operating Temperature Range	
30 degrees to 100 degrees F	SAE10W/30, SAE10W/40, SAE-30
0 degrees to 30 degrees F	10W-30 or -40
Frequency of Oil Change	Every 3 months, or 6,000 miles
Transmission Capacity	19 quarts
Tire Inflation Pressures (11 x 22.5, 16 ply tubeless)	
Front	105 lbs
Rear	75 lbs

Table 8-2

Generator Capacities and Specifications

Item	Specifications
Fuel Tank	Separate 30 gallon gas tank, fill through access panel, figure 8-1
Cooling System	Water cooled, 7 quarts

Crankcase Capacity	5 quarts w/o filter 5-½ quarts w/filter change
Oil Specifications	
30 degrees to 100 degrees F	SAE30
0 degrees to 30 degrees F	SAE10W-30
Below 0 degrees F	SAE5W-20

Table 8-3

Motorhome Capacities and Specifications

Item	Specification
Potable Water Tank	97 gallons
Holding Tank, Sewage	42 gallons
Holding Tank, Waste	60 gallons
LPG Tank	180 lbs (45 gallons)
Water Pump	2.8 GPM
Furnaces	16,000 BTU(2); 12,000 BTU(1)
Hot Water Heater	12 gallons
Batteries	4 6-volt batteries, series-parallel connected to supply 12v at 440 AH
Battery Chargers	2, 45 amperes output each
Air Conditioners	
Rear (31', 33' units)	13,500 BTU (1)
Front (31', 33' units)	10,000 BTU (1)
All (35' unit)	13,500 BTU (3)
Automotive	18,000 BTU
Hot Water Circulating Heaters	
Living Area	50,000 BTU (3)
Driver's Area	90,000 BTU
Electric Heater (Bath)	1,500 BTU

Table 8-4

12-Volt Lighting and Equipment, Current Usage

Item	(Qty)/Current (Amps)
Automotive Lighting	
Marker/Identification	(16)/9.6
Stoplights	(4)/7.2
Parking Lights	(4)/2.1
Headlights and Taillights	
Hi-beam operation	(6)/13.4
Lo-beam operation	(4)/9.2
Ignition	(1)/2.5

(continued)



Table 8-4

12-Volt Lighting and Equipment (Continued)

Item	
Instrument Panel.....	(1)/1.0
Stepwell, outside.....	(2)/2.5
Backup Lights.....	(2)/4.2
Interior Lighting	
Reading Spots.....	(7)/1.5 ea
Front Living area.....	(6)/7.8
Bathroom.....	(1)/1.3
Shower.....	(1)/1.0
Dinette.....	(2)/2.6
Kitchen.....	(1)/1.3
Bedroom.....	(4)/5.2
Windshield Wipers.....	(2)/8.0
Water Pump.....	(1)/6.2
Blower Motors	
Front Heater (Hi/Lo).....	(1)/9.0/4.5
Defroster (Hi/Lo).....	(1)/9.0/4.5
Foot Warmer (Hi/Lo).....	(1)/9.0/4.5
Rear Heater (Hi/Lo).....	(1)/9.0/4.5
LPG Furnace.....	(1)/7.3
Stereo System.....	(1)/7.3
Ceiling Vent.....	(1)/4.0

NOTE

These procedures apply only to front tire changes. A blown-out rear dual tire will not prevent you from driving to a service stop providing that you drive slowly (25 mph, maximum!). This will prevent tire overheat and possible blowout of the other tire in the pair.

WHEN A SPARE TIRE IS AVAILABLE

1. Drive motorhome out of traffic lane, if possible, onto a level surface.
2. Turn on hazard flasher and apply emergency brakes before leaving coach.
3. Turn off ignition and set transmission selector to Neutral (N) position.
4. Remove jackstand, lug wrench and handle from front right side storage compartment, figure 5-3.
5. Place wheel chocks against wheels on opposite side of work from flat tire.
6. Place jack under spring pad and raise jack slightly until securely in place. See figure 8-2 for location of typical jacking points.

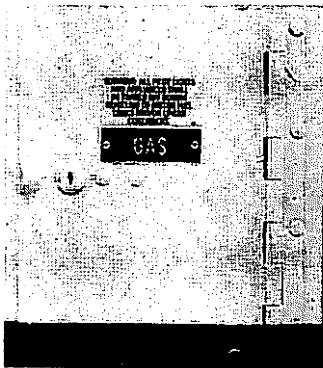

Figure 8-1. Generator Gas Tank Access Panel

CHANGING TIRES

The tires used on your motorhome are heavy-duty truck-type tires. These tires are HEAVY and may be difficult to handle. If at all possible, tire changes should be accomplished by a service station equipped to handle truck tires. However, if a situation arises where no service facilities are available, the following procedures may be used.



Figure 8-2. Locating Tire Jack



CAUTION

Truck tires are heavy! Two people will make tire handling an easier chore!

7. Remove spare tire (if available) from tire mounting and place on ground near work area.
8. Loosen lug nuts slightly, then jack up coach until tire is clear of ground.

NOTE

Lug nuts on right side of coach are right-hand threaded (turn counterclockwise to loosen, clockwise to tighten); lug nuts on driver's side of coach are left-hand threaded (turn clockwise to loosen, counterclockwise to tighten).

9. Remove lug nuts and tire.
10. Install spare tire and replace lug nuts tightly.
11. Lower coach to ground and remove jackstand and handle.
12. Replace lug wrench, jackstand and handle in storage compartment and tie down to prevent road noise. Return damaged tire to holder and have it repaired as soon as possible.
13. Remove and stow wheel chocks.
14. Turn off hazard flasher before returning to traffic.

CAUTION

Check lug nuts for tightness every 1,000 miles. Lug nuts should be torqued to 450 to 475 foot-pounds.

WHEN NO SPARE TIRE IS AVAILABLE

To replace a front tire when no spare is available, remove one of the outer rear dual tires and use this as a spare. To remove the tire, it will be necessary to run the inside dual tire up on a small wooden ramp (contained in the left rear storage compartment, figure 4-8) which is high enough to raise the outer tire above ground level.

CAUTION

For added safety, place the tire jack, extended, beneath the frame member adjacent to the inside dual tire. Remove jack before driving off ramp!

Remove the tire to be used as the spare and back the coach off the ramp. Replace the front tire by following the instructions given previously.

CHANGING A REAR TIRE

Outer tires may be changed, if a spare is available, by driving the inner tire up on the tire ramp, and then removing and replacing the tire as previously described.

BATTERIES

Your motorhome is equipped with four 6-volt batteries, connected in a series-parallel arrangement to provide 12 volts for engine and motorhome use. Batteries are located in the front outside compartment on the driver's side, as shown in figure 4-1. A separate 12-volt battery is contained in the generator compartment and is used only to start the generator; it is also charged by the generator.

The four engine/motorhome batteries are charged by the engine alternator, while the engine is operating. In addition, the batteries are also charged by two 45-ampere battery chargers during the time that generator or shoreline ac power is furnished.

PERIODIC CHECKS

Check the level of the battery electrolyte on a regular basis. The intervals at which fluid is added depend on the battery usage, climate and proper use of the battery charger. Experience with coach operation will soon provide a guide as to how often the batteries should be checked. Add only colorless, odorless drinking water, or distilled water, as necessary, to bring the electrolyte level to the



split ring visible in the filler hole opening. (A small mirror and flashlight will help to check the level.)

CAUTION

Do not expose batteries to an open flame or electric spark — battery action generates hydrogen gas, which is flammable and explosive! Avoid contact with battery acid; this is a sulphuric acid that can cause personal harm. Flush exposed area immediately with water to neutralize and remove acid. Do not allow acid to come in contact with clothes, painted surfaces, etc., or these will be damaged. Also, do not wear metal rings, watches or jewelry when working on or near the battery, cables, solenoids, or chassis wiring. These can short out electrical wiring and cause injury.

To make sure that the batteries are always ready for use, periodically check and charge as necessary. Check batteries at least every two weeks in freezing weather; at least every four weeks in warmer weather. A fully-charged battery will not freeze under normal circumstances, so it is imperative that the batteries remain charged during winter. A safe level of charge is a specific gravity reading of 1.225 to 1.280. Always use a battery hydrometer which has a temperature correction scale.

BATTERY MAINTENANCE

A dirty battery will eventually dissipate its charge through conductive surface contamination. Clean battery top surface with a damp cloth and dry thoroughly. Check that terminals are tight and free of corrosion. To clean terminals, neutralize corrosive deposits with a solution of baking soda, rinse with clear water, and dry. Note that commercial type spray-on battery cleaners are available at automotive supply stores. Use as directed to keep the batteries clean. Spray-on cable and terminal protective coatings are also available, easy to use, and effective.

EXTERIOR CARE

Exterior paint finish life can be extended by

periodic cleaning and waxing. This will preserve the paint and allow easier removal of dirt and road tars. Use touch-up paint for small areas to keep the coach finish in like-new condition.

Frequent washing of the coach is necessary to prevent corrosion when parking where heavy salt sprays are evident. A clear acrylic spray may be used, with care, to control corrosive effects of salt spray on metal surfaces.

INTERIOR CARE

The interior can be kept in good condition with the use of approved cleaning agents for vinyl walls and ceilings, plastic fixtures, stainless steel, formica and so on. Never use abrasive cleaning agents on interior of refrigerators, or on sinks, as they can cause permanent scratches. Be sure that the cleaning agent will not damage the material. Note that some plastics are incompatible with certain cleaners. Read the directions on the container before using. For the most part, the cleaners and polishes that would normally be used in your home are equally well-suited for use in your motorhome.

FLUID LEVEL CHECKS

CRANKCASE OIL LEVEL

Oil level checks can be accomplished from inside the coach by unlatching and lifting away the hood ledge cover, shown removed in figure 8-3.

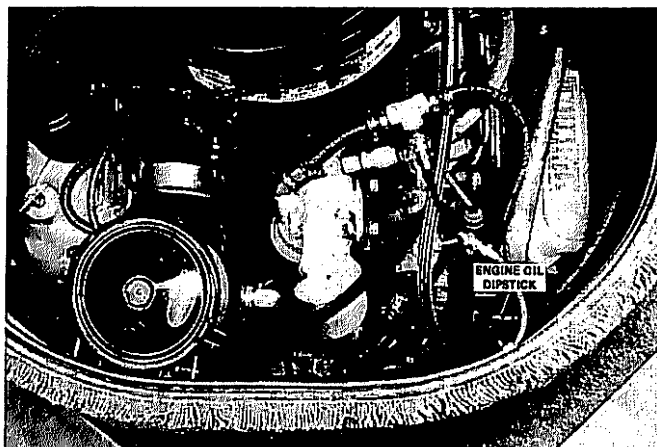

Figure 8-3. Oil Dipstick Location, Engine Hood Removed



The crankcase engine oil supply should be maintained at the proper level. If checking oil level immediately after engine has been operating, allow a few minutes for the oil to drain back into the crankcase before checking the dipstick reading.

The oil level may be checked, and oil added, from inside the coach. The best time to check the oil is before getting underway because the engine is cool and the dipstick reading will be most accurate. To check oil level, remove dipstick, wipe clean, and reinsert for an accurate reading. If oil reads at or below the "Add Oil" mark, add oil as necessary. Maintain oil level in the safety margin, staying between the "Full" and "Add Oil" markings.

POWER STEERING FLUID LEVEL

Regularly check hydraulic fluid level in the power steering pump reservoir, figure 8-4, at each fuel stop. Add power steering fluid (or automatic transmission fluid) as necessary to maintain the correct dipstick reading, depending on fluid/engine temperature. (Note that dipstick is attached to the bolt on top of the reservoir.) If the fluid is at normal operating temperature — about 150 degrees, and hot to the touch — the dipstick should indicate $\frac{1}{2}$ to $\frac{3}{4}$ full. If engine is cool, fluid level should read about $\frac{1}{2}$ full. Power steering fluid does not require periodic changing, as does automatic transmission fluid.

TRANSMISSION FLUID LEVEL

Check transmission fluid level, figure 8-5, with engine idling. Cold checks, or checks made with the engine off, will be misleading. Dipstick should read "Full".

WATER PUMP MAINTENANCE

Under normal usage, the water pump should

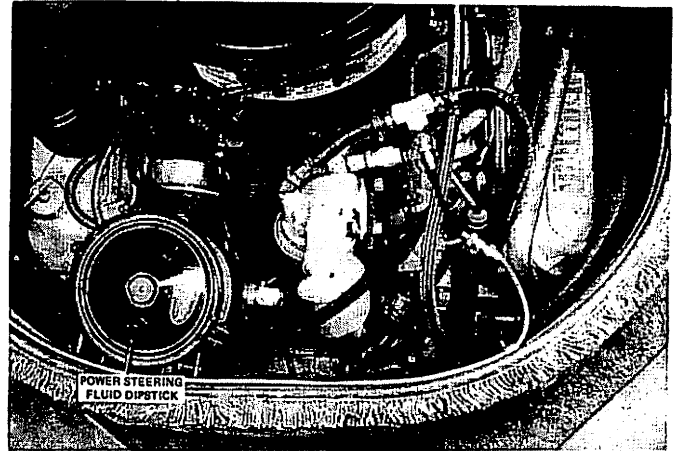

Figure 8-4. Power Steering Reservoir

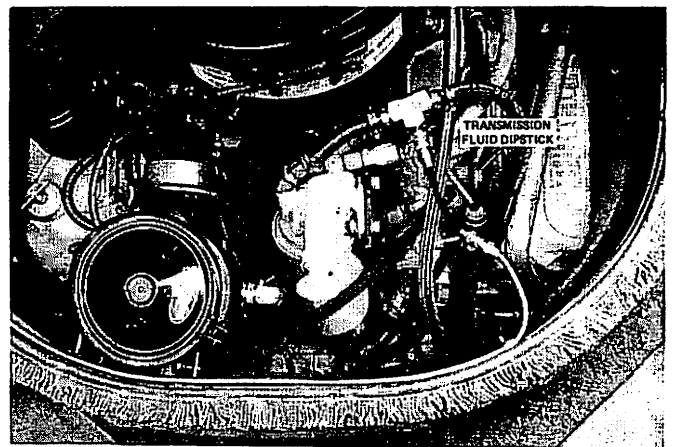

Figure 8-5. Transmission Dipstick Location

require no periodic maintenance other than ensuring that the input water supply is properly filtered of particles that could damage the pump mechanism. Pump failures can generally be tied in to the plumbing system, or to electrical supply and pump wiring. If the pump fails to turn-on and operate when power is applied, check circuit breaker, interconnecting wiring and PUMP ON-OFF switches. For other failures, refer to the troubleshooting guide given in table 8-5.



Table 8-5. Water Pump Troubleshooting Guide

Symptom	Possible Cause	Corrective Action
Pump operates but no water flows through faucet.	Low water level in tank.	Add water to tank.
	Water lines are clogged.	Blow out water lines with compressed air.
	Kink in water hose.	Check water hose connections to tank and straighten or replace, as necessary.
	Air leak in suction line.	Replace suction line.
	Dirty or hard-to-open in-line check valve.	Replace check valve.
	Defective pump valve.	Replace pump valve.
Pump cycles on and off when faucets are closed.	Water leak in plumbing.	Check for signs of leakage and tighten or replace fittings, pipe, etc.
	Defective toilet flush valve.	Repair flush valve.
	Internal leak in valve. Pump check valve not sealing.	Replace check valve.
Pump operates roughly and has excessive noise and vibration.	Intake line is restricted, kink in suction hose or fittings too small.	Check input hoses and straighten or replace, as necessary.
	Deformed or ruptured pulsation dampener in pump.	Replace dampener.
	Loosened screws at pulleys and connecting rod.	Tighten screws.
	Worn connecting rod bearing.	Factory-level repair.
Pump fails to start when faucet is opened.	Clogged piping.	Blow out water lines with compressed air.
	No voltage to pump.	Check input wiring, circuit breaker and switches.
	Defective pressure switch.	Replace pressure switch.
Pump fails to stop when faucets are closed.	Empty water tank.	Add water.
	Insufficient voltage to pump motor.	Check battery voltage. If voltage is OK, pump is defective.
	Defective pressure switch.	Replace pressure switch.



PARTS REPLACEMENT

The following paragraphs describe removal and replacement of major pump components. Refer to the exploded view, figure 8-6 for location of numbered items; refer to the parts list, table 8-6, for ordering information.

Table 8-6. Water Pump Parts List

Item	Description	Part No.	Qty.
1	Motor	30208-0000	1
2	Diaphragm plate	35503-0000	2
3	Diaphragm ring screw	34917-0000	2
4	Valve set (inlet/outlet)*	30004-0000	1
5	Base	35620-1100	1
6	Port, inlet	42986-0000	1
7	Port, discharge	43006-0000	1
8	Vibration dampener	35432-0000	4
9	Screw	35618-0000	4
10	Pulsation dampener*	35597-0000	1
11	Bottom plate	35686-0000	1
12	Screw	35508-0000	9
13	Not used		
14	Pressure switch/O-ring	37121-0010	1
15	Diaphragm retainer	35497-0000	1
16	Diaphragm screw	34679-0000	1
17	Washer, teflon	35518-0000	1
18	Diaphragm*	30015-0000	1
19	Jack shaft assembly	35689-0000	1
20	Motor mount	34628-0000	1
21	Motor nut/star washer	34681-0000	2
22	Pulley, large	35209-0000	1
23	Pulley, small	34522-0000	1
24	Belt*	30022-0000	1
25	Setscrew	35242-0000	1
26	Setscrew	36562-0000	1
27	Motor mount screw	34676-0000	4
28	Tiedown screw	34674-0000	4
29	Connecting rod assembly	35465-0000	1
30	Eccentric screw	35464-0000	1

*Service Kit — includes * items

VALVES REPLACEMENT — Proceed as follows:

1. Turn off power to the pump.
2. If system is filled with water, open a faucet to relieve pressure. Close intake and discharge lines near pump.

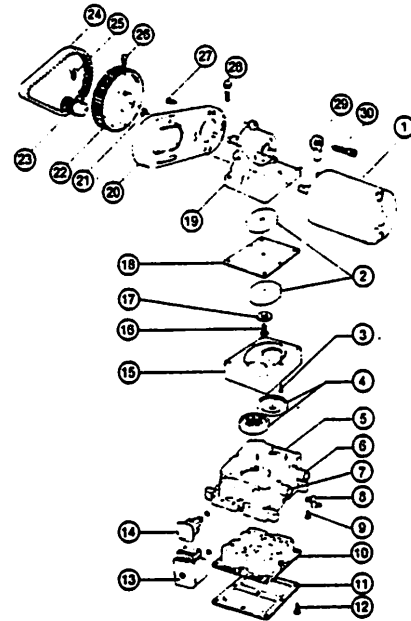

Figure 8-6. Exploded View of Pump

3. Remove motor and four tie-down screws (28).
4. Expose valves by lifting jack shaft (19) and attached diaphragm assembly from pump base.
5. Lift valves from pockets. Clean all foreign materials from valves and seats.
6. Reinstall valves into same pockets, being sure that rubber valve with small hole is UP on intake, and rubber valve without the small hole is DOWN on discharge (see view).

CAUTION

Do not use valve with small hole in rubber on discharge side of pump.

7. When reassembling, adjust belt tension to provide ¼" play.

DIAPHRAGM AND CONNECTING ROD REPLACEMENT — Proceed as follows:

1. Turn off power to the pump.
2. If system is filled with water, open a faucet to relieve pressure. Close intake and discharge lines near pump.
3. Remove motor and four tie-down screws (28), then lift jack shaft (19) and attached diaphragm assembly from pump base.



4. Expose diaphragm by removing two diaphragm ring screws (3) and detaching ring.

5. Remove diaphragm screw (16) to separate diaphragm and plates from connecting rod. Inspect diaphragm for cuts and ruptures.

6. Remove eccentric screw (30) to separate connecting rod from jack shaft.

7. When reassembling, be sure to align diaphragm and connecting rod so that rod will slip straight onto jack shaft and diaphragm rests squarely on diaphragm retainer. Misalignment will create a strain on diaphragm and significantly shorten its useful life. Adjust belt tension to 1/4" play.

PULSATION DAMPENER REPLACEMENT — Proceed as follows:

1. Turn off power to the pump.
2. If system is filled with water, open a faucet to relieve pressure. Close intake and discharge lines near pump.
3. Remove pump from installation.
4. Remove nine screws (12) from bottom of base (5) and bottom plate (11).
5. Pull out rubber pulsation dampener (10) from base.
6. Inspect dampener for excessive deformation, ruptures or cuts.

7. When installing a new pulsation dampener, make sure flange is well-seated to effect a proper water and air seal.

PRESSURE SWITCH REPLACEMENT — Proceed as follows:

1. Turn off power to the pump and open a faucet to relieve pressure.
2. Disconnect wires from pressure switch.
3. Unscrew switch from base.
4. Thread new switch, with "O"-ring, into pump base. Do not overtighten!
5. Rewire according to wiring diagram.

MOTOR REPLACEMENT — Proceed as follows:

1. Turn off power to the pump.
2. Disconnect motor wires from the pressure switch terminal.
3. Remove two motor nuts (21) to separate motor.
4. Loosen screw to slide off small pulley (23) from motor shaft.
5. When reassembling, be sure to adjust belt tension before tightening motor nuts. Proper adjustment is made when belt can be depressed 1/4" at a point half-way between pulleys.

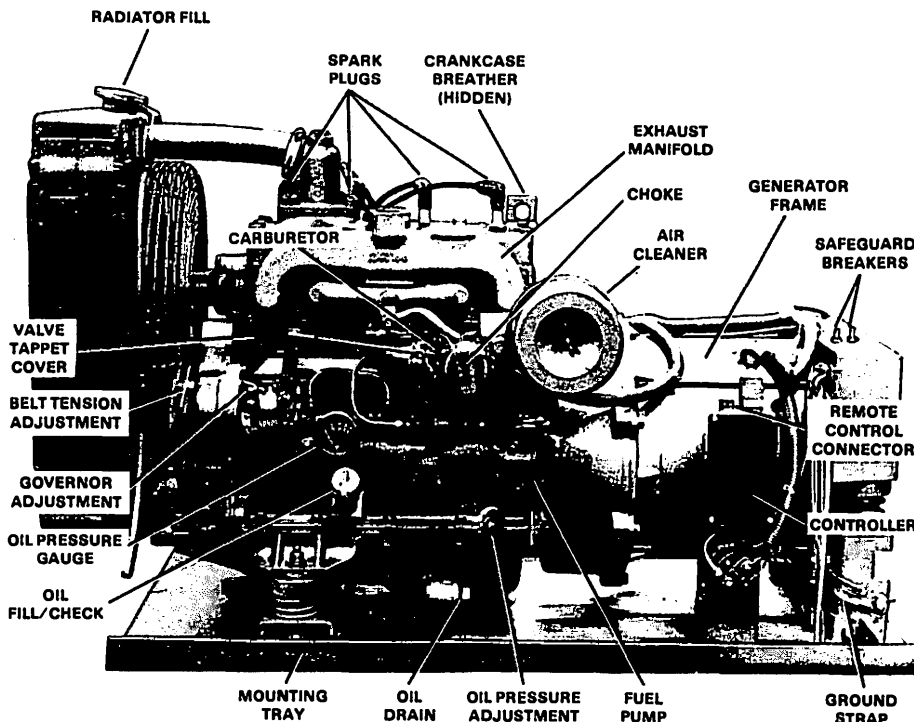

Figure 8-7. Generator Component Locations



WINDSHIELD WASHERS

Check reservoir fluid level periodically and use a prepared washer solution, if possible. During freezing weather, use a solution additive, or a solution specifically designed for cold weather usage. The washer reservoir is accessible through the front right storage compartment, figure 5-3.

GENERATOR

Keep the generator operating at peak efficiency by following a regular schedule for inspections and servicing, based on operating hours. Keep an accurate logbook record of maintenance, service and hours of operation, following regular schedules for normal operating conditions; and a more frequent service schedule for operation under dusty or dirty conditions. Check condition of crankcase oil and change air filter frequently until the proper service/time periods can be determined based on your usage.

MAINTENANCE SCHEDULES

Use the generator maintenance schedule, below, as a guide for routine and periodic maintenance procedures. Neglecting generator maintenance can result in failures or permanent generator damage. Refer to figure 8-7 for generator component locations.

Generator Maintenance Schedule

Frequency	Service
Daily, or before each startup	Check oil level Check fuel supply Clean radiator intake screen
Every 50 hours, or 6 months, whichever occurs first	Change lubrication oil Service air cleaner Check radiator coolant level Check fan belt tension Clean oil filter breather cap
Every 100 hours, or 8 months, whichever occurs first	Service spark plugs Check battery electrolyte level

Every 200 hours, or every year

Check and tighten electrical connections

Clean crankcase breather cap
Check and tighten mounting bolts

Check generator brushes, commutator and slip rings

Check ignition timing

Replace air cleaner element

Tune-up engine

Every 500 hours, or every 2 years

Contact authorized service center for overall tuneup and preventive maintenance checkout

Periodically, perform a complete visual inspection of the generator when operating at full load.

CAUTION

Use extreme caution when observing an operating generator with tray extended.

1. Check for possible leakage from oil and fuel lines.
2. Inspect exhaust line, muffler, and connections for possible cracks or leakage.
3. Periodically check air shrouds for leakage and security. Check that cooling fins are clean.
4. Inspect electrical wiring for frayed wires, corroded connections and general wire damage.

BATTERY

Check the condition of the generator battery at least every two weeks. See that battery connections are clean and secure. A light coating of non-conductive grease will prevent corrosion at terminals. Keep the battery electrolyte at the proper level above the plates by adding water, as needed. Check specific gravity and recharge if hydrometer reads below 1.250. Refer to Battery Maintenance procedures provided earlier in this section.

AIR CLEANER MAINTENANCE

Proper maintenance of the air cleaner, figure 8-7A, is extremely important. Allowing this element to become clogged with dirt restricts the flow of intake air into the engine. Inspect the



element for tiny holes or tears which would allow particles of dust or dirt to enter the carburetor. These particles can also cause excessive wear of piston rings.

Operating with an over-rich fuel mixture caused by a poorly serviced or clogged air cleaner leads to formation of harmful sludge deposits. It is a good practice to replace the element after 100-200 hours of usage, under normal conditions; and more often under dusty or dirty conditions.

Every 50 hours, or six months, remove the element and lightly tap rubber rim against a flat surface to dislodge any loose dust or dirt from the surface. Replace element if there are too many dark spots or extensive dark areas as these indicate dirt trapped within the filter material. It is not advisable to wash dry the element in any liquid or to attempt to clean it with an air hose as this will ruin or damage the paper fiber filter. When handling the element, use care to avoid crushing or bending as this will permit unfiltered air to enter the engine.

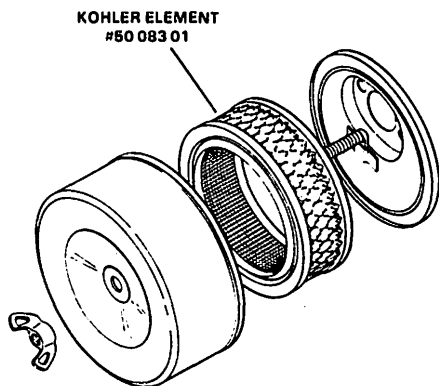

Figure 8-7A. Air Cleaner

CRANKCASE BREATHER CAP

At every fourth oil change, or every 200 hours, remove the crankcase breather cap and service by soaking and swishing in a solvent, such as kerosene. After cleaning, allow five minutes for it to dry, then lightly re-oil with engine oil before reinstalling on breather tube.

LUBRICATION

The generator engine has a positive pressure lubrication system and low-oil pressure shut-down.

NOTE

The low-oil pressure shut-down feature protects the engine from internal damage due to oil pump failures or other malfunctions causing low oil pressure. It does not protect against damage due to operating with oil level below the safe range since it is not a low-oil level shut-down. The only protection against running out of oil is periodic checks and addition of oil to keep level constant.

OIL CHECK — To be on the safe side, check oil in engine crankcase daily, or before each start, to ensure that the level is in the safe range between the "L" and "F" marks on the dipstick, figure 8-8. Do not operate generator if level exceeds "F" mark, or is below "L" mark.

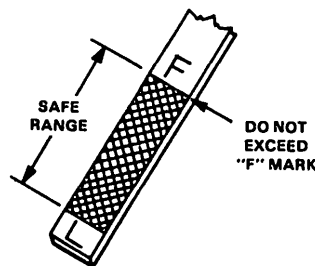

Figure 8-8. Oil Dipstick

CAUTION

Do not check oil level while engine is operating. Engine must be stopped to obtain a true reading, as well as for safety reasons!

After the engine has been thoroughly warmed up and is operating with the proper weight of oil in the crankcase, the oil pressure should be about 20 psi. An external oil pressure adjustment screw,



figure 8-9, is provided on the crankcase just below and to the rear of the carburetor. If normal pressure is lower than 20 psi, remove acorn nut, loosen locknut, then turn screw until pressure is correct. Secure locknut at new setting and reinstall protective acorn nut. When engine is cold, pressure may be as high as 50-60 psi, but should gradually return to about 20 psi as the engine warms up.

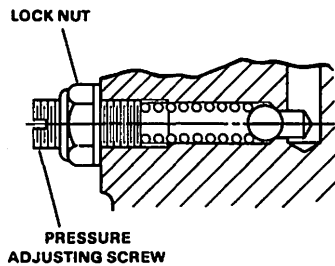

Figure 8-9. Oil Pressure Adjustment

OIL CHANGE — On a new engine, change the oil after the first five hours of operation and, thereafter, at 50 hour intervals or every five months, whichever occurs first. Whenever possible, drain

the oil while the engine is still warm. To drain, place a container below the unit, open the oil drain and allow sufficient time for the old oil to drain completely. After draining, close drain plug and tighten securely. Note that the oil refill is 5 U.S. quarts.

OIL TYPE — The lubricating oil used must meet the requirements of the American Petroleum Institute (API) Service Classification SC, SD, SE, or CC (MS). Oil weight (SAE viscosity) is selected according to anticipated ambient temperatures. Use a straight-weight SAE30 oil when temperatures are above 30 degrees F (–1 degree C); use SAE-10W30 when temperatures are in the range of 30 degrees F (–1 degree C) to 0 degrees F (–18 degrees C); and use SAE5W-20 when temperatures fall below 0 degrees F (–18 degrees C). The API Service Classification and SAE viscosity numbers are stamped or printed on the oil can.

COOLING SYSTEM

To avoid having the inconvenience of the generator shutting down due to overheating, or becoming damaged as a result of an overheat condition, be sure to keep the cooling air inlets to the

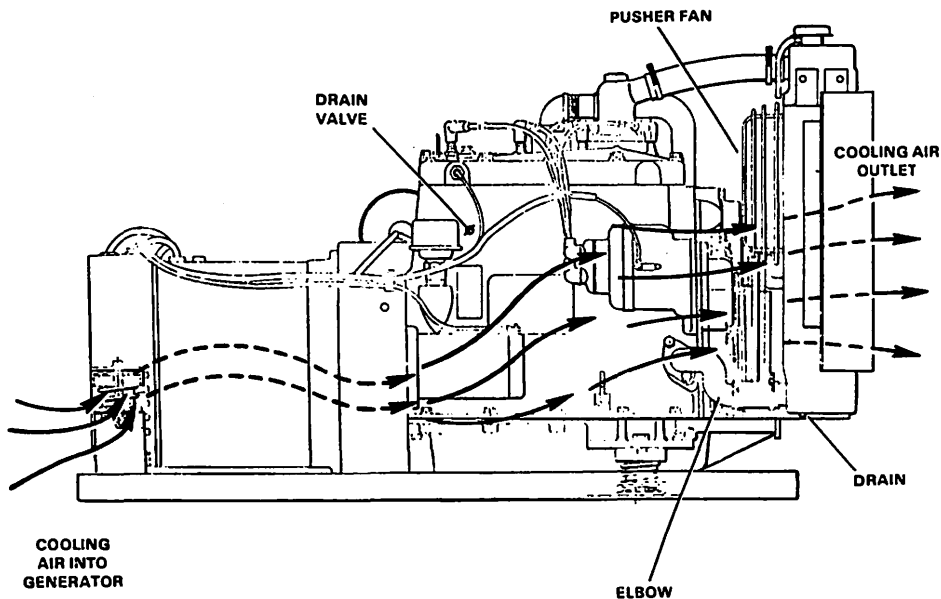

Figure 8-10. Generator Cooling System



compartment clean and unobstructed at all times.

Cooling system capacity is about 7 quarts of liquid. When operating in climates subject to freezing temperatures, make sure that enough anti-freeze solution is added to the coolant to prevent system freeze-up. As shown in figure 8-10, a drain petcock is provided on the underside of the radiator to drain the system. When draining the coolant, remove the radiator cap and open the block drain valve near the oil filler cap to prevent air pockets from forming and blocking water in passages in the block.

Check coolant level frequently and add water or anti-freeze as needed to maintain correct level.

Before adding anti-freeze, drain the coolant system completely to assure correct proportions of anti-freeze to water. For example, to protect a 7-quart capacity radiator system to -11 degrees with ethylene glycol, use a 40% solution, as shown in the chart given below. [This is figured as $.40 \times 7$ quarts = 2.80 or, rounded off, 3 quarts of anti-freeze to 4 quarts of water = 7 quarts total.]

For maximum protection always use a solution which will remain liquid below the lowest anticipated temperature.

Anti-Freeze Protection Chart

AntiFreeze Protects to:	Mixture Proportions (ethylene glycol)				
	10%	20%	30%	40%	50%
+16 degrees F (-9 degrees C)		x			
+3 degrees F (-16 degrees C)			x		
-11 degrees F (-24 degrees C)				x	
-31 degrees F (-35 degrees C)					x

FUEL AND CARBURETOR ADJUSTMENTS

Use a good quality regular grade gasoline with a pump sticker rating of at least 85 octane (90 octane-research method). Low-lead or non-leaded gas is recommended to reduce combustion chamber

deposits. Oil must not be mixed with fuel. Avoid using gasoline that is not freshly purchased; "stale" gasoline will cause gum deposits to form in the carburetor. Add fuel stabilizer if the gasoline will remain in the tank more than six months.

IDLE ADJUSTMENT — An idle adjustment, figure 8-11, is provided on the carburetor although the engine operates at idle speed only briefly as it comes up to speed after being started, or when it slows after being shut down. The idle adjustment is not critical and can be permanently set at two turns open position.

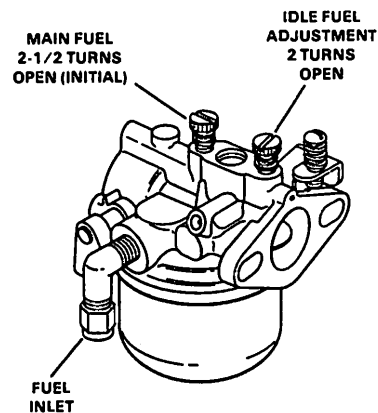

Figure 8-11. Idle Fuel Adjustments

MAIN FUEL ADJUSTMENTS —

1. Stop engine and carefully turn main fuel adjustment all the way in (clockwise) until the needle bottoms lightly. Do not force closed or the needle or seat may be damaged.

2. For preliminary adjustment: turn main fuel adjustment out (counterclockwise) $2\frac{1}{2}$ full turns.

3. Start engine and allow it to warm up to normal operating temperature. If possible, place the engine under a normal operating load while making final adjustment.

4. For final adjustment: move main fuel needle in until engine starts to slow down from too lean a mixture (note position of screw adjustment). Then back out on adjustment until speed increases. Continue backing out until speed again starts to drop from too rich a mixture. The correct position of the needle is about halfway between these two extremes.



CHOKE ADJUSTMENT — The choke adjustment is set for average conditions. To readjust, loosen three screws on outside of cover plate, figure 8-12, then shift cover in clockwise direction, for richer setting; or in counter-clockwise direction, for a leaner setting. Tighten cover screws after final adjustment.

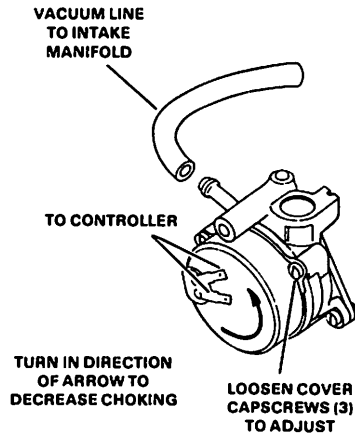

Figure 8-12. Choke Adjustment

IGNITION SYSTEM

SPARK PLUGS — Remove and check the condition of the spark plugs every 100 hours of operation. Reset gaps or replace plug, as necessary. A good indication of a normally-operating plug is a light gray or tan deposit on the electrodes. A dead white, blistered coating is usually an indication of overheating; while a black (carbon) coating may indicate an “over-rich” fuel mixture caused by a

clogged air cleaner or improper carburetor adjustment. Do not sandblast, wire-brush, scrape or service a plug in poor condition. Replace plug and gap new plug to .025” (.635 mm).

MAGNETO BREAKER POINTS — always replace badly burned or pitted breaker points. A certain amount of buildup or metal transfer may occur under normal operating conditions. However, if this condition is excessive, or occurs frequently, the condenser may be at fault. Slightly pitted points can be dressed with a point file, although this should be done only as a temporary “fix”, since points tend to arc more after filing. Replace points at first opportunity after filing. If the points are oxidized, rubbing a piece of coarse material between the surfaces will remove much of the oxide. Do this with dirty or oily points as well but make sure that no pieces of material are left between the points to cause later problems.

The breaker points are located under the end cap of the magneto. Use the following procedure to adjust the point gap, referring to figure 8-13.

1. Remove end cap, turn engine over until breaker points are fully open.
2. Measure open gap with feeler gauge. The maximum opening is .015” (.381 mm). Adjust gap by loosening gap adjusting screw, then insert screwdriver blade in notch and shift movable plate until .015” gap is obtained.
3. Tighten gap adjusting screw and replace end cap after adjustment is completed.
4. After breaker point gap is set, adjust timing.

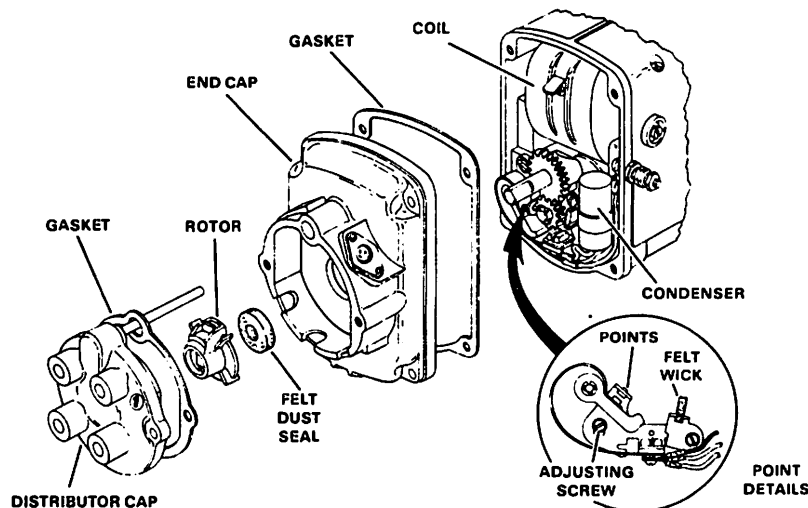

Figure 8-13. Breaker Point Adjustment



IGNITION TIMING — Timing is changed by shifting position of the magneto. Final timing is made with a timing light and should be done by a qualified mechanic, using the following procedures:

1. Set breaker point gap as described in the previous paragraph.
2. Connect timing light to number 1 cylinder. Before starting, rotate engine until "S" mark is observed in the timing sight hole on the generator adapter.
3. Start engine and operate at 1,800 RPM.
4. Aim timing light into sight hole and note that light flashes coincident with appearance of "S" mark, centered in hole. If light flashes before mark appears, timing is retarded; if light flashes after mark appears, timing is advanced.
5. To adjust, loosen, but do not remove, magneto flange mounting capscrews and shift or turn the magneto until the timing mark is exactly centered as the light flashes.
6. Tighten mounting flange screws after adjustment is completed.

BELT TENSION ADJUSTMENT

Belt tension should be set so that the belt can be depressed about $\frac{1}{2}$ " to 1" in the center of the longest span between pulleys, as shown in figure 8-14.

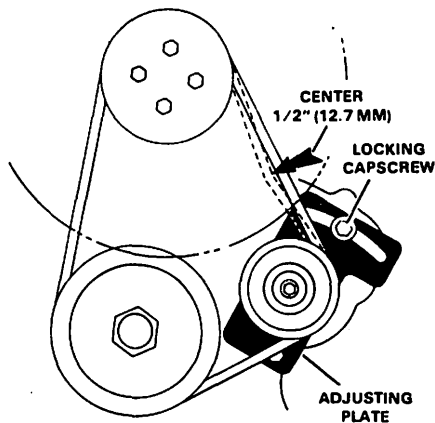

Figure 8-14. Belt Tension Adjustment

To adjust belt tension, loosen the two mounting capscrews and shift plate outward to increase the tension; or shift plate inward to reduce tension. Move plate all the way inward to remove a worn or damaged belt. Retighten capscrews after the proper tension is obtained.

GOVERNOR ADJUSTMENT

With the constant speed governor, figure 8-15, the throttle shaft linkage is fixed at a definite length to establish a specific load speed of 1,800 RPM. No adjustment should be made to the throttle shaft because any variations in specified engine speed causes frequency changes in the generator output voltage. For this reason, only slight readjustment of the speed is possible.

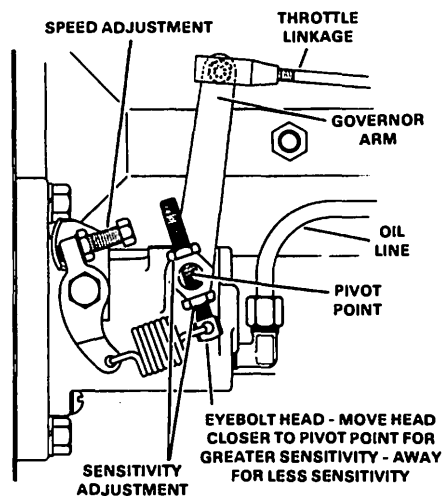

Figure 8-15. Governor Adjustment

If the governor setting is too sensitive, hunting or speed surging will occur with changing load. If a considerable drop in speed is experienced when full or rated load is applied, the governor should be adjusted for greater sensitivity.

If one of the governor settings is readjusted, the other should also be readjusted since each has an affect on the other. With the generator operat-



ing at full or rated load, governed speed, readjust the governor as described in the following paragraphs.

SPEED RANGE — Check speed with a hand tachometer or frequency meter.

1. Loosen locking nut on speed adjusting screw and turn screw clockwise, to increase speed; or counter-clockwise, to decrease speed.
2. Lock nut in at new adjustment setting.

SENSITIVITY — (Droop Adjustment) Test under normal load conditions. If readjustment is needed, proceed as follows:

1. Loosen nut at bottom of adjusting eyebolt and tighten top nut, drawing head of eyebolt closer to governor arm pivot point, to make the governor control more sensitive; OR
2. Loosen nut at top of adjusting eyebolt and tighten bottom nut, moving head of eyebolt away from governor arm pivot point, to make governor control less sensitive.
3. After desired sensitivity is obtained, tighten the nut that was previously loosened and lock eyebolt in at new setting. Recheck speed after adjustment to verify correct setting.

GENERATOR TROUBLESHOOTING

Under normal conditions, generator service will not be required on a regular basis. If operating under extremely dusty and dirty conditions, use dry compressed air to blow dust out of generator at frequent intervals. Do this with the generator set operating and direct the stream of compressed air in through the cooling slots at the end of the generator.

Due to generator design, brushes should not require service very often. The brushes operate at very low currents and should last indefinitely. Abrasive dust on the collector rings could, however, shorten the life of the brushes. If brush replacement becomes necessary, due to poor or no ac output, have repairs made by a qualified repair agency.

Table 8-7 lists some common causes of generator troubles that may be detected and corrected without special equipment. If problems occur, observe the indicator lights on the generator remote control panel to aid in locating the problem area. If routine servicing or the corrective actions given in table 8-7 fail to correct the trouble, have the generator serviced by a qualified repair agency.

Table 8-7. Generator Troubleshooting Guide

Symptom	Possible Cause	Corrective Action
No ac output: GREEN Light ON.	Safeguard breakers inadvertently left in OFF position.	Reset breakers to ON position.
	Safeguard breakers tripping due to overloading.	Reduce generator load.
	Short circuit in coach wiring causing breakers to trip.	Reset breakers. If breakers trip repeatedly, stop generator and have serviced.
No ac output: GREEN Light OFF.	Generator problem, such as: sticking brushes, broken brush leads, or other internal fault.	Have generator repaired by service center.
Low output voltage, or excessive drop in voltage: GREEN Light ON.	Engine speed too low.	Adjust governor.
	Overload condition.	Reduce generator load.



Table 8-7. Generator Troubleshooting Guide (Continued)

Symptom	Possible Cause	Corrective Action
Low output voltage, or excessive drop in voltage: GREEN Light ON. (cont.)	Engine in poor condition	If routine services are performed and the trouble continues, have generator repaired by service center.
Generator stops abruptly.	Low oil pressure.	Check oil level, filter, etc.
	Overheating causing safety shutdown.	Service cooling system.
	Out of fuel.	Replenish fuel supply.
	Engine malfunction.	Refer to service center for repairs.
	Fuse blown in controller.	Replace fuse. If fuse blows repeatedly, refer to service center for repairs.

GENERATOR OVERLOADS — If the rated capacity of the generator is exceeded, the safeguard circuit breakers, located on top of the generator end cover (figure 8-7), will trip to protect the generator against damage. This condition could be caused by a short in the coach ac supply circuits, or by operating too many appliances simultaneously, resulting in an overload condition. If the safeguard circuit breaker trips, the generator will continue running but no ac output will be supplied. Before resetting the circuit breakers, turn off some of the coach appliances and lighting to reduce the load to within the operating limits of the generator. If this is done, and the generator breakers still trip, a short circuit is indicated. Turn off the generator, locate and correct the cause of the short circuit.

FUSE REPLACEMENT — There is one 10 ampere fuse located inside the relay controller, figure 8-7. This fuse protects the controller against damage in the event that a short circuit develops within the wiring harness to the remote start-stop switches and wiring inside the coach. If this fuse blows, the generator will stop. In addition, this fuse also protects the generator assembly from internal malfunctions. Controller fuse location is shown in figure 8-16.

CAUTION

Disconnect battery before removing cover from controller.

If set has stopped due to causes other than lack of fuel, engine malfunction, overheating, or low oil pressure, remove the cover from the controller and check the fuse. If blown, replace fuse and restart generator. If fuse blows again, refer generator to a service center for repairs.

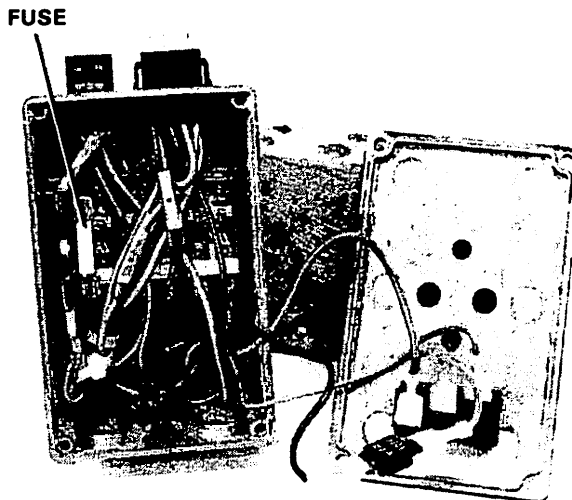

Figure 8-16. Controller Fuse Location



ENGINE TROUBLESHOOTING

When troubles in the generator engine occur, don't overlook simple causes which might seem too obvious to be considered. A starting problem, for example, could be attributed to an empty fuel tank. Systematically check all possibilities before

referring the generator to a service center.

As a general aid to diagnosing common causes of engine troubles, refer to table 8-8. This chart includes the manufacturer's recommendations for items to check when there are generator engine malfunctions.

Table 8-8. Engine Troubleshooting

Problem	Fuel Related Causes			Ignition Causes			Other Causes					
	No Fuel	Improper Fuel	Fuel Mix. Wrong	No Spark	Poor Ignition	Improper Cooling	Improper Lubrication	Poor Compression	Valve Problems	Carbon Build-Up	Governor Faulty	Engine Overloaded
Will Not Start	X			X				X	X			
Hard Starting		X	X		X	X		X	X			
Stops Suddenly	X			X			X		X			
Lacks Power		X	X		X	X		X	X	X		X
Operates Erratically		X	X		X						X	
Knocks or Pings		X	X			X				X		X
"Skips" or Misfires			X		X							
Backfires			X		X				X	X		
Overheats			X		X	X	X		X			X

STORAGE PROCEDURES

If the generator is to be out of service for a long period of time, perform the following procedures before placing the unit in storage:

1. Drain oil from crankcase (while hot) then flush with clean light-weight oil. Refill crankcase with regular-weight oil after flushing.

2. Drain fuel from carburetor bowl. This is necessary to prevent the gasoline from becoming "stale", which results in the formation of gum deposits.

3. Remove the spark plugs, pour about 1 tablespoon of oil into each hole, crank engine several times, then replace spark plugs.

4. Clean exterior surfaces of generator set then spread a light film of oil over any unpainted metallic surfaces which could corrode.

ROUTINE SERVICE PARTS

Commonly-used parts are listed in table 8-9.

Table 8-9. Common Generator Parts

Description	Part Number
Air Intake Element, Air Cleaner	50-083-01
Cylinder Head Gasket	231453
Generator Parts	
Brush	238151
Spring, Brush	238150
Holder, Brush	238153
Ignition System and Magneto Parts	
Breaker Points Set	266240
Gasket, End Cap	153996
Sparkplug	41-131-05
Condenser	266562
Gasket, Distributor Cap	266906
Rotor	241047
Exhaust System Parts	
Muffler	241730
Clamp	277706
Spark Arrestor	277679
Clamp	237548
Hanger	237549



SUBURBAN DYNA-TRAIL FURNACE

MAINTENANCE

The Suburban Dyna-Trail furnace units do not normally require routine maintenance or cleaning. However, if, for any reason, the main burner has been allowed to operate with a high yellow flame, a soot formation is sometimes deposited inside the combustion chamber. This carbon deposit

may be of such quantity that cleaning will be required. To clean the combustion chamber, there is an access hole on the front of each radiation chamber. A vacuum cleaner is ideal for cleaning out carbon deposits. The blower motor is the sealed, permanently-oiled type and requires no oiling.

A general guide to furnace troubleshooting is provided in table 8-10.

Table 8-10. Suburban Dyna-Trail Furnace Troubleshooting Guide

Symptom	Possible Cause	Corrective Action
No heat.	Thermostat off.	Check to be sure that thermostat is calling for heat. Check for defective thermostat wiring.
	Gas supply shut off.	Check that manual gas valve is in open position, with lever parallel to gas line.
	Poor electrical connections or low battery voltage.	Check battery supply voltage. If battery is low, there will be sufficient power to run the blower, but not at full speed. This will prevent the air-operated microswitch from being actuated, gas will not flow to the main burner, and the spark will be missing. Be sure that the terminal wiring and connections are not loose or broken.
	Defective microswitch.	Check that the microswitch is "sailing" in far enough to open the solenoid gas valve and energize the spark module board. If the switch is not sailing in far enough, clean dust or dirt from the actuator pin. If the switch is still not actuating the control circuits, check: — Insufficient blower speed (slow motor due to low-charged battery, faulty motor, lint or dust accumulation on blower wheels, restriction of furnace return air. — Incorrectly-wired motor (polarity reversed). — Faulty microswitch, if valve does not operate when switch is manually operated. Also, switch should be replaced if battery is fully charged, motor runs at top speed, and switch still fails



Table 8-10. Suburban Dyna-Trail Furnace Troubleshooting Guide (Continued)

Symptom	Possible Cause	Corrective Action
No heat (continued)		to engage or actuate in 6 to 7 seconds. Note that the combustion chamber must be pulled out to service the switch. If the chamber can be pulled out from the rear, do so as far as needed to visually and manually check the switch.
	Defective gas valve.	Use a test light to check voltage at gas valve terminals. If voltage is present, but valve is not opening (when micro-switch engages), replace gas valve. (To replace the valve the chamber must be removed first.)
	Blower inoperative.	Check for a burned-out motor. On dual-voltage furnaces, the ac/dc switching relay may be defective. Check by connecting a shorting wire across terminals 3 and 4. If relay clicks, but motor fails to start, replace motor. If no "click" is heard, replace relay.
	Short cycling (fan switch).	If burner and fan shut off simultaneously when the thermostat is satisfied, this indicates that the fan switch is shorted. Replace switch. (Chamber must be removed.)
	Defective relay.	Relay may be defective if motor fails to start when thermostat calls for heat. This will be evidenced by a click when the thermostat setting is raised and the motor fails to operate.
	Electrode not sparking with blower running and microswitch engaged.	Check for 12 volts at spark module circuit board. If no voltage appears, check circuit wiring for fault. — If voltage is present, but module board is not flashing, replace module board. — Module board flashing but electrode still not sparking, check electrode wiring connections. — Wiring checks out correctly, but not sparking through when removed from electrode and grounded, replace electrode wire.



Table 8-10. Suburban Dyna-Trail Furnace Troubleshooting Guide (Continued)

Symptom	Possible Cause	Corrective Action
No heat (continued).		<ul style="list-style-type: none">— Electrode wire sparks against ground when removed from electrode, replace electrode assembly.
	Incorrectly positioned electrodes. (Electrode sparks and gas valve opens but goes into lockout.)	Check that electrode is positioned approximately 3/16" above and directly over one of the sawed slots on the main burner assembly.
Excessive noise.	Blower out of balance.	Replace blower.
	Motor hums.	Replace motor.
	Insufficient primary air.	Adjust primary air input.
Erratic blower operation. (Blower cycles on and off rapidly after unit heats up.)	Defective automatic blower motor overload switch.	Replace blower motor.
	Loose blower assembly causing squirrel cage wheel to drag.	Tighten assembly mounts.
Unit is inoperative.	Faulty wiring.	Check all wiring connections and terminals for possible shorts, loose connections or open circuits. On dual-voltage units, check the following items: <ul style="list-style-type: none">— Proper wiring to ac/dc converter.— Transformer for burnout or shorts.— Diodes.— Ac/dc switching relay.— Replace entire converter assembly if the problem cannot be traced to any one converter component; or if there is excessive voltage or loading on the input to the converter.— If furnace thermostat is observed opening and closing rapidly when the furnace starts, the gas valve may be shorted, or a wire may be shorting out. Replace gas valve if symptom stops when gas valve is disconnected.



AIR CONDITIONING SYSTEM

MAINTENANCE

Cleaning the return air filters is the only maintenance that should be performed. Under normal operating conditions, the filters should be cleaned on a weekly basis. Clean filters as follows:

1. Turn unit off.
2. Remove return air grilles and filters. Use a smooth flat object, such as table knife. Insert this between the center of the switch (or label) end of the grille and, with a twisting action, gently pry the grille out until the mounting pins are free of the corresponding holes in the plenum assembly.
3. Wash filters and grilles in warm soapy water. **DO NOT USE SOLVENTS!**
4. Rinse filters and grilles with fresh water and dry.
5. Replace filters and grilles in unit.

NOTE

When replacing the grilles be sure to install with notched (cutout) sides up toward the switch and label plates. If grilles are mounted incorrectly, mounting pins will not fit holes and pins may be broken.

CAUTION

Do not cycle compressor on and off rapidly or compressor may be damaged. Once the compressor has been turned off, wait several minutes for system pressure to equalize before restarting.

1. **DO NOT** turn the air control knob from a cool position to OFF and then immediately back to a cool position.
2. **DO NOT** turn air control knob from any COOL position to a FAN ONLY position and then back to COOL.
3. **DO NOT** turn the temperature control from a colder setting to a warmer setting and then back again rapidly.

DOMETIC REFRIGERATOR

MAINTENANCE

FLAME BLOWOUT — If trouble is encountered with the flame blowing out under especially windy conditions, try to avoid the wind blowing against the wall where the vent outlets are located. If the trouble remains, set the thermostat to MAX position. (This should be done only as a temporary measure because, after a day or more at this setting, the foodstuffs in the cabinet will freeze.)

CAUTION

Before performing refrigerator maintenance procedures that require disassembly, make sure that the power source is disconnected, and that the LPG supply is turned off.

BURNER ASSEMBLY CLEANING AND ADJUSTMENTS — Once or twice each year, depending on usage, it is recommended that the burner assembly be removed and cleaned thoroughly. Shut down LPG supply, then proceed as follows:

1. Disconnect gas pipe from the burner assembly.
2. Remove the burner jacket.
3. Remove the burner housing.
4. Clean the jet with alcohol and compressed air **ONLY**.
5. Clean the burner tube, and especially the gauze, with a brush.
6. Blow out dust with compressed air.
7. Reassemble, reconnect power supply and turn on LPG.
8. Check the burner with full flame (thermostat set to MAX) and with by-pass flame (if the refrigerator has been operating for a few hours and the thermostat bulb is colder than 43 degrees F). The transition from full flame to by-pass can be observed if the thermostat knob is turned slowly from MAX to zero.

At the same time, check that the flue baffle is



clean and reasonably free from soot. Heavy soot formation indicates improper functioning of the burner. Clean baffle and flue. Also, clean cooling unit and floor beneath refrigerator. Check entire gas installation periodically for leaks at pipe connections. Refer to table 8-11 for troubleshooting.

PIEZO LIGHTER — The refrigerator is equipped with a piezo lighter, which does not normally require maintenance. If the lighter does not operate properly, refer unit to service center for repair.

IMPROPER THERMOSTAT OPERATION —

Check position of the capillary tube between the evaporator fins. The end of the capillary tube must be in direct contact with the evaporator. The capillary tube contacts the evaporator via one of two methods: (a) Capillary tube is inserted into a spring clip which is fastened between two fins; or, (b) The capillary tube is fastened between two fins with a brace and screws. If the position of the capillary end is incorrect, reset accordingly. If no improvement results, replace thermostat.

Table 8-11. Dometic Refrigerator Troubleshooting Guide

Symptom	Possible Cause	Corrective Action
Insufficient cooling.	Jet orifice clogged	Clean jet orifice. Disengage gas pipe from burner, unscrew nipple with jet, blow clear of dirt and wash in alcohol. Do not use wire or a pin to clean orifice!
	Flame is out.	Check that refrigerator is properly leveled. Also check that feeler point of flame failure safety device is heated by the flame.
	Clogged bypass screw.	Clean or replace screw.
	Air circulation around unit is restricted.	Check for proper air circulation.
	Evaporator heavily coated with frost.	Defrost unit. Check that flue baffle is correctly inserted into central tube of cooling unit. Also check that thermostat is set properly.
	Gauze in burner head is clogged.	Clean.
	Burner damaged.	Replace burner.
	Burner positioned wrong.	Re-position burner.
	Incorrect burner gas pressure.	Check gas pressure at burner and source. Pressure at burner must not fall below 11" W.G. when thermostat is at MAX.
	Odor from fumes.	Flames contacting sides of boiler.
Burner damaged		Replace.



AIR CONDITIONING SYSTEM

MAINTENANCE

Cleaning the return air filters is the only maintenance that should be performed. Under normal operating conditions, the filters should be cleaned on a weekly basis. Clean filters as follows:

1. Turn unit off.
2. Remove return air grilles and filters. Use a smooth flat object, such as table knife. Insert this between the center of the switch (or label) end of the grille and, with a twisting action, gently pry the grille out until the mounting pins are free of the corresponding holes in the plenum assembly.
3. Wash filters and grilles in warm soapy water. **DO NOT USE SOLVENTS!**
4. Rinse filters and grilles with fresh water and dry.
5. Replace filters and grilles in unit.

NOTE

When replacing the grilles be sure to install with notched (cutout) sides up toward the switch and label plates. If grilles are mounted incorrectly, mounting pins will not fit holes and pins may be broken.

CAUTION

Do not cycle compressor on and off rapidly or compressor may be damaged. Once the compressor has been turned off, wait several minutes for system pressure to equalize before restarting.

1. **DO NOT** turn the air control knob from a cool position to OFF and then immediately back to a cool position.
2. **DO NOT** turn air control knob from any COOL position to a FAN ONLY position and then back to COOL.
3. **DO NOT** turn the temperature control from a colder setting to a warmer setting and then back again rapidly.

DOMETIC REFRIGERATOR

MAINTENANCE

FLAME BLOWOUT — If trouble is encountered with the flame blowing out under especially windy conditions, try to avoid the wind blowing against the wall where the vent outlets are located. If the trouble remains, set the thermostat to MAX position. (This should be done only as a temporary measure because, after a day or more at this setting, the foodstuffs in the cabinet will freeze.)

CAUTION

Before performing refrigerator maintenance procedures that require disassembly, make sure that the power source is disconnected, and that the LPG supply is turned off.

BURNER ASSEMBLY CLEANING AND ADJUSTMENTS — Once or twice each year, depending on usage, it is recommended that the burner assembly be removed and cleaned thoroughly. Shut down LPG supply, then proceed as follows:

1. Disconnect gas pipe from the burner assembly.
2. Remove the burner jacket.
3. Remove the burner housing.
4. Clean the jet with alcohol and compressed air ONLY.
5. Clean the burner tube, and especially the gauze, with a brush.
6. Blow out dust with compressed air.
7. Reassemble, reconnect power supply and turn on LPG.
8. Check the burner with full flame (thermostat set to MAX) and with by-pass flame (if the refrigerator has been operating for a few hours and the thermostat bulb is colder than 43 degrees F). The transition from full flame to by-pass can be observed if the thermostat knob is turned slowly from MAX to zero.

At the same time, check that the flue baffle is



clean and reasonably free from soot. Heavy soot formation indicates improper functioning of the burner. Clean baffle and flue. Also, clean cooling unit and floor beneath refrigerator. Check entire gas installation periodically for leaks at pipe connections. Refer to table 8-11 for troubleshooting.

PIEZO LIGHTER — The refrigerator is equipped with a piezo lighter, which does not normally require maintenance. If the lighter does not operate properly, refer unit to service center for repair.

IMPROPER THERMOSTAT OPERATION —

Check position of the capillary tube between the evaporator fins. The end of the capillary tube must be in direct contact with the evaporator. The capillary tube contacts the evaporator via one of two methods: (a) Capillary tube is inserted into a spring clip which is fastened between two fins; or, (b) The capillary tube is fastened between two fins with a brace and screws. If the position of the capillary end is incorrect, reset accordingly. If no improvement results, replace thermostat.

Table 8-11. Dometic Refrigerator Troubleshooting Guide

Symptom	Possible Cause	Corrective Action
Insufficient cooling.	Jet orifice clogged	Clean jet orifice. Disengage gas pipe from burner, unscrew nipple with jet, blow clear of dirt and wash in alcohol. Do not use wire or a pin to clean orifice!
	Flame is out.	Check that refrigerator is properly leveled. Also check that feeler point of flame failure safety device is heated by the flame.
	Clogged bypass screw.	Clean or replace screw.
	Air circulation around unit is restricted.	Check for proper air circulation.
	Evaporator heavily coated with frost.	Defrost unit. Check that flue baffle is correctly inserted into central tube of cooling unit. Also check that thermostat is set properly.
	Gauze in burner head is clogged.	Clean.
	Burner damaged.	Replace burner.
	Burner positioned wrong.	Re-position burner.
	Incorrect burner gas pressure.	Check gas pressure at burner and source. Pressure at burner must not fall below 11" W.G. when thermostat is at MAX.
	Odor from fumes.	Flames contacting sides of boiler.
Burner damaged		Replace.



Table 8-11. Dometic Refrigerator Troubleshooting Guide (Continued)

Symptom	Possible Cause	Corrective Action
Odor from fumes (cont.)	Flame contacts flue baffle.	Replace burner; re-position flue baffle.
	Flue tube is dirty.	Clean flue tube. Cover burner and jet then remove flue top and baffle. Clean flue tube of deposits, clean baffle, then replace.

AQUA MAGIC TOILET MAINTENANCE

No routine maintenance is required. Refer to table 8-12 for a troubleshooting guide. If the bowl sealing blade does not operate freely after extended usage, it may be restored to its original smooth operating condition by applying a light film of

silicone spray to the blade.

To clean the toilet, use Thetford Aqua Bowl or any other high-grade, non-abrasive cleaner. Do not use highly concentrated or high-acid content household cleaners. They may damage the rubber seals.

Table 8-12. Aqua Magic Toilet Troubleshooting Guide

Symptom	Possible Cause	Corrective Action
Water keeps running into bowl.	Blade in bottom of bowl is not closing completely, preventing water control valve from closing fully. Sealing groove is clogged.	Insert end of a coat hanger or similar object into sealing groove and remove foreign material. Avoid damaging rubber seal while cleaning.
Toilet leaks water on floor.	Defective vacuum breaker.	If vacuum breaker leaks when toilet is flushed, replace vacuum breaker.
	Defective water control valve.	If vacuum breaker leaks when toilet is not operating, replace water control valve.
	Poor bowl-to-mechanism seal.	Remove mechanism, replace seal.
	Poor closet flange base seal.	Check front and rear closet flange nuts for tightness, tighten as needed. If leak continues, remove toilet, check that closet flange height is between 1/4" and 7/16" above floor. Adjust closet height accordingly and replace flange seal.
Foot pedal difficult to operate; blade sticks.	Inadequate lubrication.	Apply a light film of silicone spray to blade.



ENGINE OPERATIONAL CHECKLISTS

Use the following checklists, which are based on routine servicing procedures employed by Bluebird service facilities, as a guide to periodic engine and coach systems service schedules.

Frequency	Item Checked
ENGINE	
As required	Check engine oil. Check transmission oil. Check radiator coolant. Check battery water, main engine and generator engine coolant levels every 2 weeks during cold weather; every 4 weeks during warm weather. Check power steering reservoir.
Every 1,000 miles	Tighten wheel lug nuts to 450 - 475 foot/pounds. Check tire pressures: 105 psi, front; 75 psi rear.
Every 2,000 miles	Lubricate chassis. Drain water from fuel tank and/or Racor fuel filter. Drain water from air brake reservoirs.
First 3,000 miles	Set valve lash.
Every 6,000 miles	Change engine oil (Delo 400, MS, Series 3, or equivalent.) Check governor high-low idle.
Every 6,000 to 10,000 miles	Rotate tires: front to back same side. (Removal

Every 48,000 miles

and/or replacement of alloy wheels/discs for cleaning and inspection.
Fuel ignition nozzles.
Check governor high-low idle.

GENERATOR

Every 50 hours

Clean governor linkage.
Service air cleaner.
Change oil.

Every 100 hours

Change oil and filter.
Replace sparkplugs.

Every 500 hours

Check brushes.

MISCELLANEOUS

Every 500 hours

Replace air filter.
Remove soot deposits from appliance combustion chambers.

Check valve clearances.

Quarterly

Inspect fire extinguisher to see if fully charged.
Lubricate window channels with silicone or graphite.

Annually

Perform quarterly maintenance.
Tighten all body tie-down bolts to 18 foot/lbs.
Clean heater cores.
Bleed air from heaters.
Tighten all heater hose clamps and check heater hoses.
Service/replace PCV valve.
Service/replace thermostat.



SECTION IX

GENERAL INFORMATION

Equipment	Manufacturer	Model or Type (if assigned)
Air Conditioner	Frigiking Corporation P.O. Box 20738 Dallas, Texas 75220	10,000 BTU Model, Chiller 11 13,000 BTU Model, Chiller 13
Auxiliary Generator	Redi-Line Motor Generators Honeywell Motor Products P.O. Box 106 Rockford, Illinois 61105	Redi-Line
Awning	Zip-Dee Incorporated 96 Crossen Avenue Elk Grove, Illinois 60007	
Bath Vent	Hammond Manufacturing Corporation P.O. Box 5393 2220 Raymond Drive Lansing, Michigan 48905	Model CB-350-B Compact Blower
Bathroom Faucet	Moen Division of Stanadyne Elyria, Ohio	Series 4600
Burglar Alarm	Universal Security Instruments Incorporated 10324 South Dolfield Road Owing Mills, Maryland 21117	Model ES-250
CB Radio	Motorola Incorporated 1299 East Algonquin Road Schaumburg, Illinois 60196	Electroscan Model CM540
Central Air Conditioner	Cruisair Marine Development P.O. Box 8570 Richmond, Virginia 23226	
Central Vacuum	Central Vac International 3133 East 12th Street Los Angeles, California 90023	Model 612 Wall-Recessed
Closed Circuit TV	RCA Corporation Electronic Components Division New Holland Avenue Lancaster, Pennsylvania 17604	Monitor Model TC1206 Camera



MAJOR EQUIPMENT MANUFACTURERS (continued)

Equipment	Manufacturer	Model or Type (if assigned)
Cook Top	Magic Chef Incorporated P.O. Box 1145 Elkhart Indiana 46514	Model BT-2235-4TX
Electric Bath Heat	Martin Industries Electric Products Division P.O. Box 271 Athens, Alabama 35611	
Electric Heater Freeze Protector	Electric Trading Company 313-315 Canal Street New York, N.Y. 10013	Ventilaire 900 watt
Electric Heater	Fasco Industries 810 Gillespie Street Fayetteville, North Carolina 28302	Model 2450, 2,000 watt "cheater"
Entertainment Center	Panasonic Corporation One Panasonic Way Secaucus, New Jersey 07094	Booster, Model CJ-3510EU Tuner, Model CX-9500EU 8-track Player, Model CX-1100EU Cassette Player, Model CX-7100EU
Fluorescent Lights	RGM Industries 3340 Lillian Boulevard Titusville, Florida 32780	Model 15RF12
Food Center	Scovill Industries NuTone Division Madison and Red Bank Roads Cincinnati, Ohio 45277	Power Unit, Model 251 Food Processor, Model 256
Fuel Filter Water Separator	Racor Industries 1137 Barium Road Modesto, California 95351	Model 900FF
Furnace	Suburban Manufacturing Company P.O. Box 399 Dayton, Ohio 37321	Dyna-Trail Model NT-12 Dyna-Trail Model NT-16
Holding Tanks	The Fiberglass Shop Dalton, Georgia 30720	Gray Water Tank — 42 /60 gallons Sewage Tank —42 gallons
Hot Water Heater	Raritan Engineering Company 1025 North High Street Millville, New Jersey 08332	Model R-12-E

control board
5210999



MAJOR EQUIPMENT MANUFACTURERS (continued)

Equipment	Manufacturer	Model or Type (if assigned)
Ice Maker	Instamatic 2323 Middleburg Street Elkhart, Indiana 46514	Model BI-35
Instant Hot Water	Manesco 151 Haven Avenue Port Washington, N.Y. 11050	Konstant Hot
LP Gas Grill	Charmglow Products P.O. Box 127 Bristol, Wisconsin 53104	Model TPC
LPG Tank	Brunner Engineering and Manufacturing Bedford, Indiana 47421	Model B527804
Leveling Jacks	HWH 105 Ninth Street Rock Island, Illinois 61201	
Microwave Oven	Thermador Division of Norris Industries 5119 District Boulevard Los Angeles, California 90040	Model MC-25
Power Generator	Kohler Company Kohler, Wisconsin 53044	7.5KW or 12.5KW
Radio (AM/FM Stereo)	Panasonic Rowland Schlesinger Associates 1538 Beech Valley Way, N.E. Atlanta, Georgia 30306	Model RA-6800
Range and Oven	Magic Chef Incorporated P.O. Box 1145 Elkhart, Indiana 46514	Model BRT 743S-5T
Reading Lights	Wemac 3433 West Harvard Santa Ana, California 92904	Model 5010 with No. 1383 bulb
Refrigerator (Electric)	Norcold 1501 Michigan Street Sidney, Ohio 45365	Model DE-728



MAJOR EQUIPMENT MANUFACTURERS (continued)

Equipment	Manufacturer	Model or Type (if assigned)
Refrigerator (Gas/Electric)	Dometic Sales Corporation 2900 Sales Corporation 2900 West Mishawaka Road P.O. Box 490 Elkhart, Indiana 46514	Model RM100
Safeline Warning Device	Ominfac Corporation 1700 East Whipp Road Dayton, Ohio 45440	
Shower Hose	Alsons Corporation 42 Union Street Hillsdale, Michigan 49242	
Shower Valve	Moen Divison of Stanadyne 377 Woodland Avenue Elyria, Ohio 44035	Series 3100/3200
Water Tank	Inca Plastics Incorporated 6400 Louisiana Avenue Nashville, Tennessee 37209	Model 00129
TV Antenna	RCA Distributors Incorporated 1500 Marietta Boulevard, N.W. Atlanta, Georgia 30318	Model 5MS440
Thermasan Waste Disposal Unit	Thetford Engineering Corporation P.O. Box 1258 Ann Arbor, Michigan 48106	Model BL-2500
Toilet - Marine	Thetford Corporation P.O. Box 1258 Ann Arbor, Michigan 48106	Aqua Magic Model 60
Toilet - Recirculating	Thetford Corporation P.O. Box 1258 Ann Arbor, Michigan 48106	Electra Magic Model 80
Washer/Dryer	General Electric Company - Major Appliance Div. Louisville, Kentucky 40225	
Water Pump	Peters and Russell 531 Liberty Street Springfield, Ohio 45501	Model 36950 - 12 volt
Water Purifier	Western Purifier 4662 Lankershim Boulevard North Hollywood, California 91602	Ogden Model BT Plan 1

HOOD REMOVAL

HOOD LEDGE AND HOOD REMOVAL
WANDERLODGE

Remove Cushion From Top of Hood Ill. #1.
Remove Tray From Top of Hood by Placing Both Hands and
Pulling Straight Up Ill. #2.

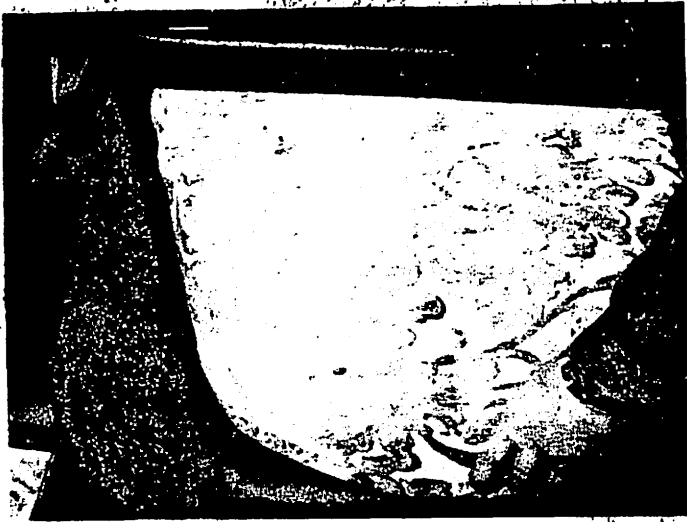

Ill. #1

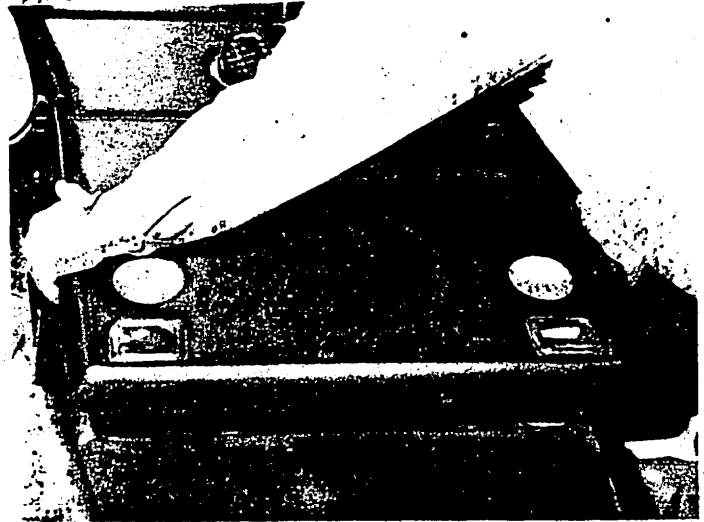

Ill. #2

Raise Hood to Open Position and Remove Two Screws From Noise
Reduction Angle Ill. #3.
Pull Angle to One Side and Remove Two Nuts and Bolts From Hood
Prop and Allow to Swivel Free and Close Hood Ill. #4.



Ill. #3



Ill. #4

HOOD REMOVAL

HOOD LEDGE AND HOOD REMOVAL
WANDERLODGE

Remove Two Hinge Pins Ill. #5 and Remove Hood.
Remove Four Screws From Right Hand Panel and Remove Panel Ill. #6.

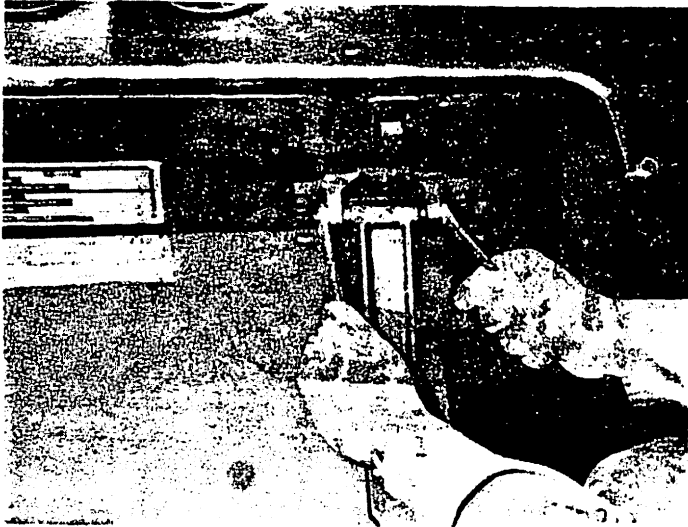

Ill. #5

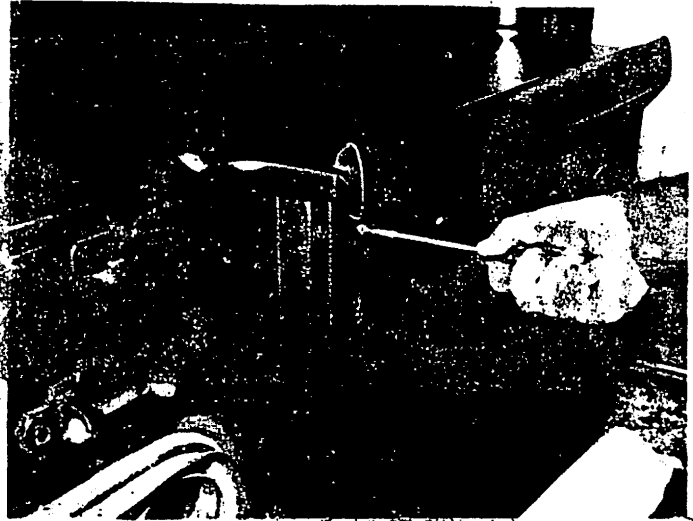

Ill. #6

Remove Nuts and Bolts From Right and Left Front Sides of Hood Ledge
Ill. #7.

Remove Eleven Bolts Through Floor Around Base of Ledge Ill. #8.

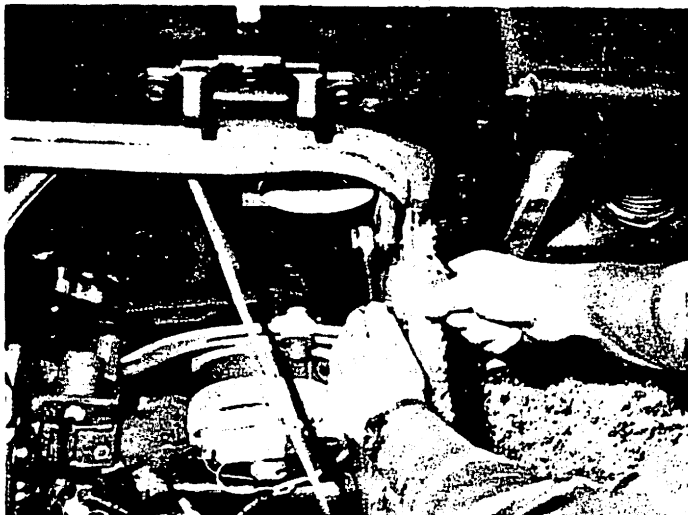

Ill. #7



Ill. #8

HOOD REMOVAL

HOOD LEDGE AND HOOD REMOVAL
WANDERLODGE

Remove Three Nuts and Bolts From Right Hand Side of Ledge
I11. #9.
Raise Hood Ledge Several Inches to Clear Floor, Slide Back and
Remove Completely.



I11. #9

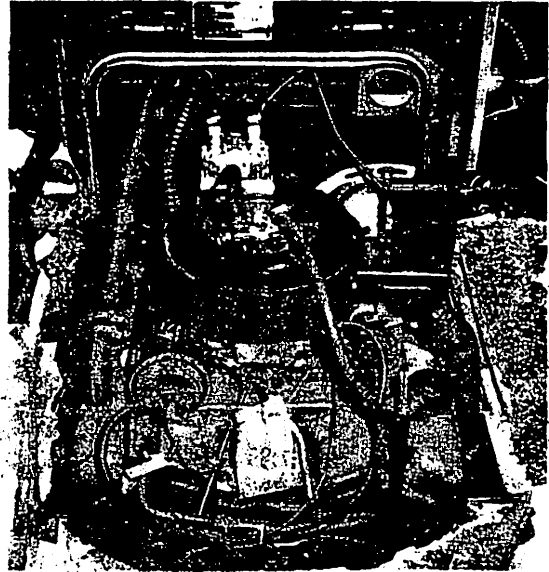

I11. #10

To Replace Hood Ledge, Reverse the Above Procedure.

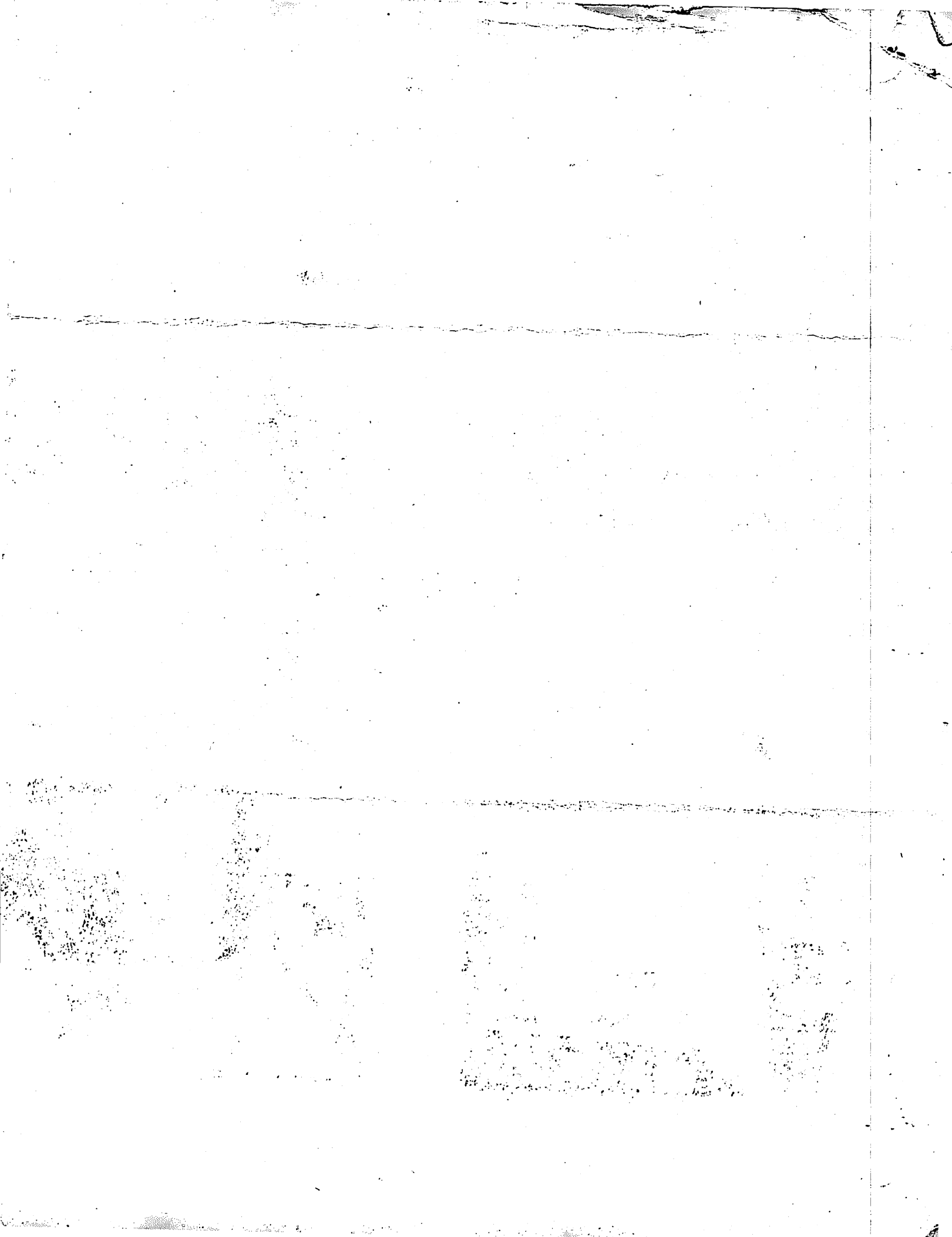

WARNING: INSTALLATION OF THIS PRODUCT NEAR POWER LINES IS DANGEROUS. FOR YOUR SAFETY, FOLLOW THE INSTALLATION DIRECTIONS.

Before you do anything else, read the booklet on safety precautions, "How To Install Your Own Antenna" which is packed in the carton with this antenna.

RCA

AC-DC Mini-State Antenna System

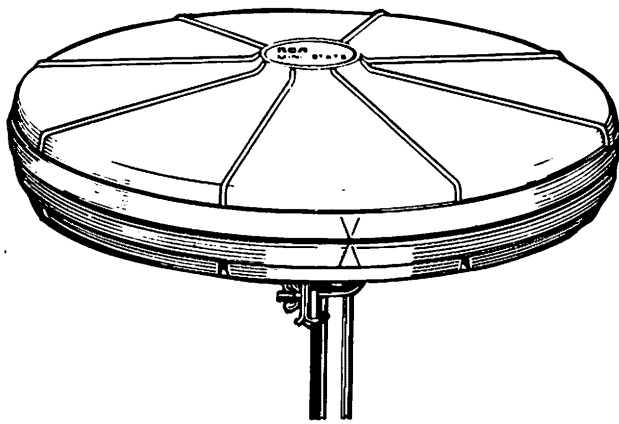

**VHF-UHF
Model 5MS550**

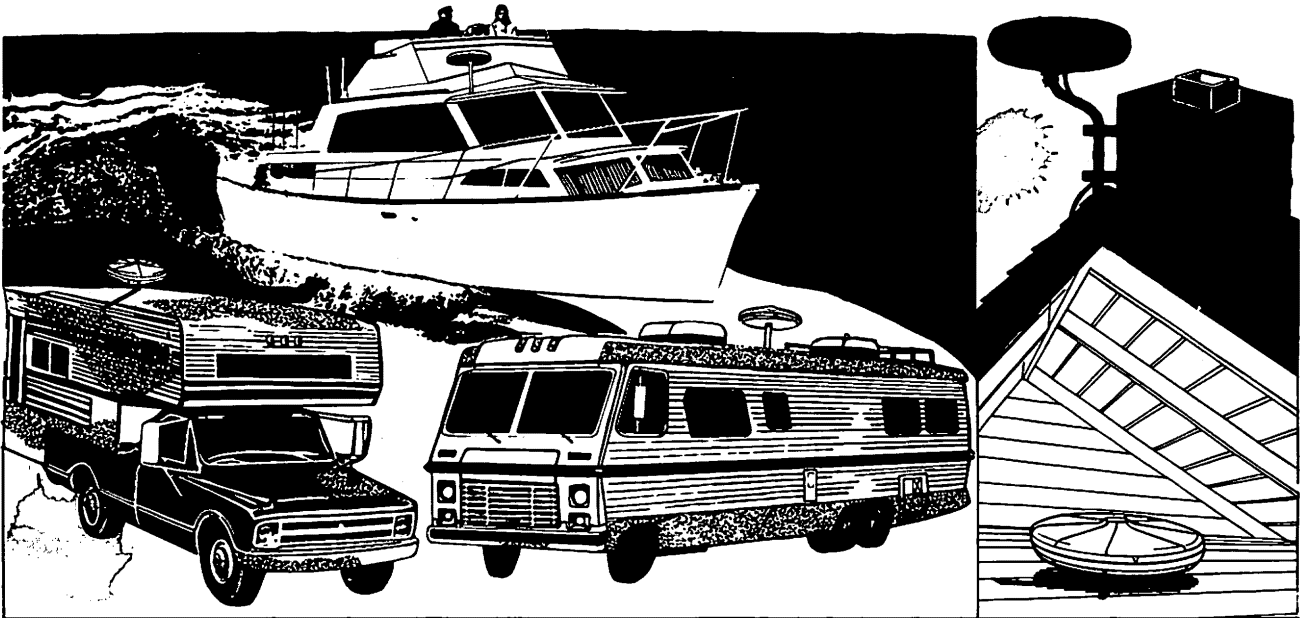

Figure 1. Typical Antenna Locations.

Items Supplied

The following items are included in the 5MS550:			
QUANTITY	DESCRIPTION	QUANTITY	DESCRIPTION
1	Radome Unit with VHF and UHF antennas, amplifier and rotator	3	Hairpin Mounting Legs for indoor use of antenna
1	Rotator Control Unit with 8' cable	1	30' Combination Coaxial/3-Wire Rotator Cable
1	120 VAC/12 VDC (Negative Ground) Power Supply Unit with VHF/UHF Band Separator attached		
1	DC Power Cord		
1	Bracket and 2 screws for mounting Power Supply		
1	All stainless steel Mast Mounting Bracket and hardware, (4 screws, 4 lockwashers, 1 U-bolt, 2 nuts)		

OPTIONAL ACCESSORIES	
Combination Coaxial/3-Wire Rotator Cable, 60'	5MS404
80'	5MS403
Offset Mast for use with wall, chimney or window mounting brackets	5MS501
Fold-Down RV Antenna Mount	5MS502
Tri Mount Kit (tripod for roof mounting)	10Y514
Two-Set Coupler	10G217

Description

The RCA AC-DC Mini-State 5MS550 is a completely new type of TV antenna system designed for use on recreational vehicles, boats and residential dwellings. Under average conditions, the reception range of the antenna is 35 miles from the TV transmitter antenna. The system contains a miniaturized unidirectional antenna, special solid state amplifier and an electrical rotating mechanism, all housed inside a weatherproof "radome". The remote power supply is designed to operate from either a 120 VAC or 12 VDC (negative ground) power

source. The package also includes a VHF/UHF band separator, rotator control unit with illuminated direction indicators, and stainless steel hardware.

A 30-foot length of low loss coaxial cable with a screw-type F-connector at each end, and a 3-wire rotator cable to interconnect the antenna and power supply are supplied to complete the installation. Both of these cables are contained in a prefabricated, single jacket cable assembly included with this unit.

Installation

ANTENNA UNIT

CAUTION: During the installation of the 5MS550 Mini-State Antenna make sure the antenna and mast cannot accidentally come into contact with any power line. CONTACT WITH POWER LINES COULD RESULT IN SERIOUS INJURY OR DEATH.

For protection against electrical static charge build-up during thunder storms, it is recommended that the antenna mast be properly grounded using at least #10 AWG copper or #8 AWG aluminum wire.

Recreational Vehicles and Boats

For best performance on vehicles and boats, the 5MS550 antenna should be mounted as high as practical and as far away from metal objects as possible. If the interior areas of the

vehicle or boat are substantially enclosed or surrounded by metal surfaces, an exterior mounting location must be selected for the antenna. For recreational vehicles with metal roofs, the antenna should be mounted at least two feet above the roof surface. For boats, best reception will normally be obtained if the antenna is mounted above the boat's highest deck or cabin structure. However, it is possible that other mounting locations may also provide satisfactory reception. It is recommended that several mounting locations be tried to find the one that provides optimum performance before a permanent installation is made.

Mounting instructions using standard hardware are given in the following paragraphs. Instructions for installing special mounting hardware (available as optional equipment) are provided with each special hardware package.

Residential Dwellings

Due to its small size, the AC-DC Mini-State Antenna will mount in a variety of places. While a rooftop installation is preferred for residential dwellings, the antenna will usually

perform well on an outside wall, window frame, or in high indoor locations such as attics, overhead crawl spaces, or on the shelf of an upstairs clothes closet. In difficult reception areas, it may be worthwhile to experiment with different locations to find the one that provides the best TV picture.

Mounting Position

For proper operation, the antenna must always be mounted with the radome in a horizontal plane. In exposed outdoor locations, it should be mounted with its top side up. When used indoors, it may be mounted in an inverted position with no sacrifice in performance; however, the direction of rotation indicators on the control unit will be reversed.

Coaxial Cable/Rotator Wire Connections (Figure 2)

Loosen the two screws and remove the terminal board cover from the underside of the radome housing. This will expose a threaded coaxial receptacle and 3 special screw type Terminals. Screw the coaxial connector on one end of the lead-in cable firmly onto the threaded receptacle.

CAUTION: Be sure the center conductor of the connector is in the hole of the receptacle before tightening.

Fasten the yellow rotator control wire to Terminal 1, the black wire to Terminal 2, and the red wire to Terminal 3. Insert the wire into the clamping terminals as shown. Replace the terminal cover so that the coaxial cable comes out the elongated slot in the bottom of the cover and the rotator control cable comes out through the notch in the side. Tighten the terminal cover screws. This will clamp the rotator cable.

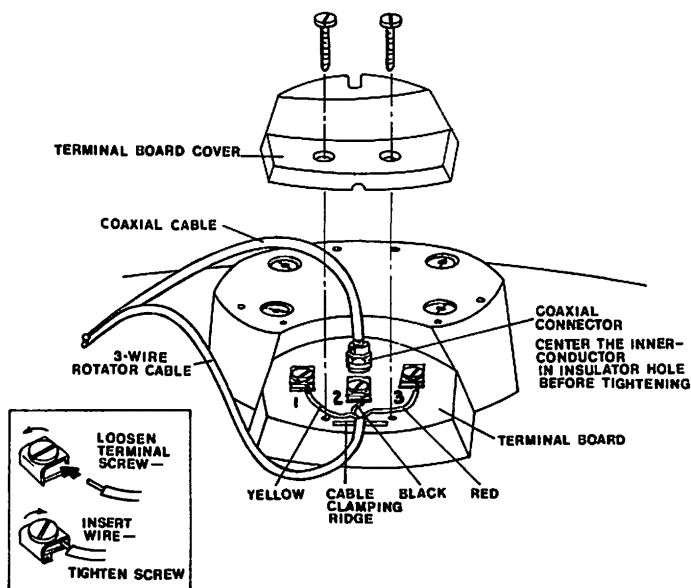

Figure 2. Connections to Antenna Terminal Board.

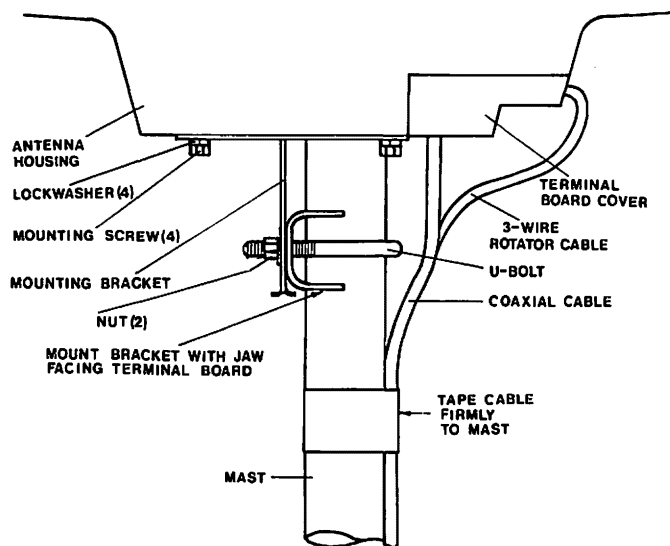

Figure 3. Mast Mounting of Antenna.

Floor or Shelf Mounting

Insert the 3 hairpin type legs into the pairs of matching holes on the underside of the antenna housing so that they angle outward to form a tripod support.

Mast Mounting (Figure 3)

A stainless steel mounting bracket is provided for mounting the antenna to a standard TV mast. Attach this bracket to the bottom of the antenna housing using the 4 screws and lockwashers provided. These screws thread into 4 slotted metal inserts. Orient the bracket as shown, so that the pipe jaws of the bracket face toward the terminal cover.

NOTE: Do not attempt to unscrew the metal inserts because these hold the internal mechanism in place.

Clamp the bracket and antenna assembly to the mast using the U-bolt and 2 nuts provided.

Antenna Orientation

Because of the built-in rotator, the antenna orientation is not critical; however, a double arrowhead is molded into the outer rim of the radome that indicates the center of rotation of the system. In a residential or fixed location, pointing the double arrowhead toward the TV transmitter antenna will reduce the amount of rotation required for best reception.

For non-fixed locations such as recreational vehicles or boats, the antenna may be installed with the double arrowheads facing in any direction. Optimum TV reception may be obtained by orienting the antenna with the built-in rotator.

Connector Assembly Instructions

Step 1: Separate coaxial and rotator cables for a length of 5½". Strip back outer insulation from 3 rotator leads 1¼" from ends. Strip inner insulation from ends exposing ¼" bare wire.

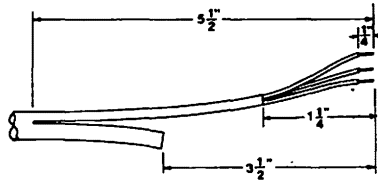

Step 2: Cut coaxial cable 3½" shorter than rotator cable.

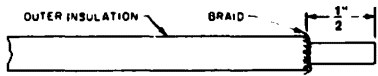

Step 3: Remove ½ inch of outer insulation.

Step 4: Comb braid out straight. Bend back and cut short as shown

Step 5: Cut off exposed aluminum foil.

Step 6: Remove 5/16 inch of inner insulation. Take care not to nick center conductor.

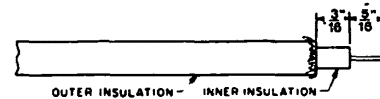

Step 7: Insert prepared end of cable into connector until center conductor protrudes approximately 1/8 inch as shown. (Caution: Do not allow the inner insulation to protrude into the connector's threaded section.)

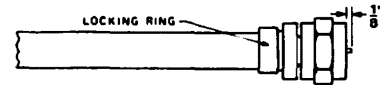

Step 8: Using a crimping tool or a pair of pliers as shown, crimp the connector locking ring.

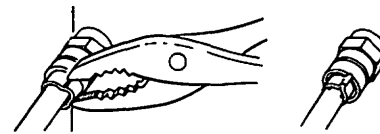

Figure 4. Installation of Connector to Shortened Cable.

Cable Installation

Tape the combination coaxial and rotator cable to the mast as shown in Fig. 3. Run the cable to the TV set location securing it every 3 to 4 feet using suitable cable clamps or U-shaped staples.

CAUTION: Clamps or staples should not press tightly against or cut through the coaxial cable. Excessive distortion of the coaxial cable may weaken the TV signal.

The cable requires a ½" diameter hole for entry through the wall or floor. To make it easier to insert the cable through the hole, fold the separated rotator cable back against the coaxial cable so that the coaxial connector goes through the hole first.

NOTE: If the coaxial and rotator cable assembly is too long, it may be shortened and a new connector (RCA 10GFO59) assembled to the coaxial cable as shown in Fig. 4.

POWER SUPPLY UNIT

The power supply unit may be operated from either a 120 VAC or a 12 VDC (negative ground) power source. These two voltages may be applied separately or simultaneously.

CAUTION: The 12 VDC circuitry of the 5MS550 Mini-State Antenna is designed to operate only with common negative ground systems. Use with positive ground systems will result in costly damage to the unit.

The power supply unit also serves as a junction box for cable connections. It can be mounted to the back of the TV set or to a surface behind the set.

Coaxial Cable/Rotator Wire Connections (Figure 5)

Attach the coaxial connector to the threaded receptacle on the power supply unit using care to center the inner conductor of the coaxial connector in the hole of the receptacle before tightening the nut. Slip the rotator cable through the strain relief clamp, and connect the yellow wire to Terminal 1, black wire to Terminal 2 and red wire to Terminal 3.

Insert the 5-pin cable plug from the hand control unit into the mating 5-pin receptacle on the power supply unit. Connect

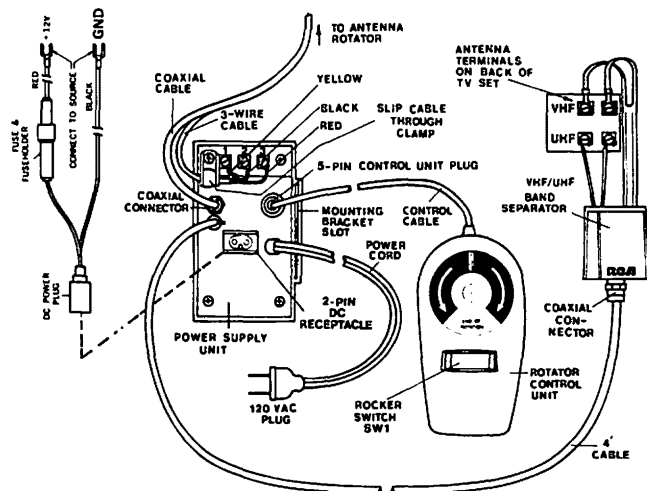

Figure 5. Antenna System Interconnections.

the band separator leads to the UHF and VHF antenna terminals of the TV set. These leads are identified on the band separator case. If the TV set has a VHF coaxial antenna receptacle, and there are no UHF stations in the area, the coaxial cable's F-connector may be unscrewed from the band separator and re-attached directly to the TV receiver's coaxial receptacle. This may help to reduce ghosts and interference in extremely difficult reception areas.

12 VDC Operation

The DC power cord supplied with the system contains an in-line protective fuse.

CAUTION: For continuous protection against fire hazard, replace fuse with only the same type 0.8 ampere/250 volt rating.

Insert the 2-pin plug of the DC power cord into the mating 2-pin DC receptacle on the power supply unit. Attach the red wire to the positive terminal and the black wire to the negative terminal of the DC source used. The power cord is supplied with spade lugs. These may be easily removed if your installation requires another type of connector.

Attach the power supply mounting bracket as shown in Figure 6 and slip the power supply onto its bracket.

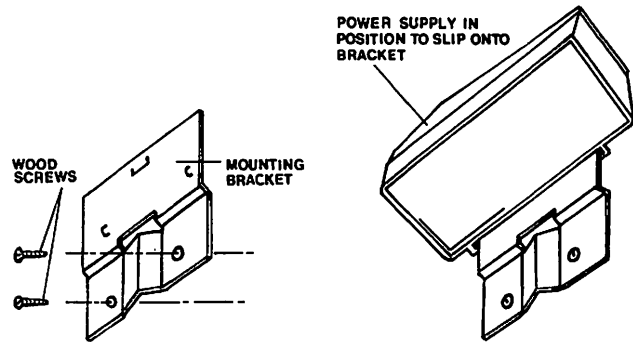

Figure 6. Power Supply Mounting.

120 VAC Operation

Insert the power cord into any convenient 120 volt AC outlet. The power cord may be left plugged in at all times because the power used is very small, about the same as that of an electric clock. The DC source, if any, may also be left plugged in, since the unit will operate from either one or both sources.

Operation

With the TV set on and a station tuned in, rotate the antenna by pressing the rocker switch located on the control unit. Pressing the right side of the switch will turn the antenna in a clockwise direction. Pressing the left side will turn it counterclockwise. Although the actual antenna movement cannot be seen, the indicator arrow on the control unit will

light, showing the direction of antenna rotation.

When the antenna has made one full turn (360 degrees), the End of Rotation light will come on.

Observe the picture while rotating the antenna first in one direction and then the other, until the best picture quality is obtained.

Circuit Description

The Mini-State 5MS550 system consists of an antenna, amplifier, rotator drive unit, rotator control unit, power supply and VHF/UHF band separator.

The VHF section of the antenna is a circularly shaped, slot tuned, broadband, unidirectional traveling wave antenna. The UHF section is a broadband multi-element array. The VHF signal is amplified and combined with the UHF signal by means of an adder circuit. The combined VHF-UHF signal travels down a coaxial cable to the power supply and through C6 to the band separator, where they are separated and transformed to 300 ohms for connection to the TV set.

The power supply provides all the operating voltages for the system. Eleven volts DC for amplifier power is supplied through the RF coaxial cable. The ground return circuit for the amplifier is via the coaxial cable shield. The power supply also provides DC voltage at socket pins 4 and 5 to energize the rotator motor and lamp circuits.

A small DC motor turns the antenna. Direction of rotation is determined by switch SW1. An end-stop switch opens the motor circuit when the antenna has rotated to its end position. Diodes D1 and D2 allow the motor to reverse and rotate off the end-stop.

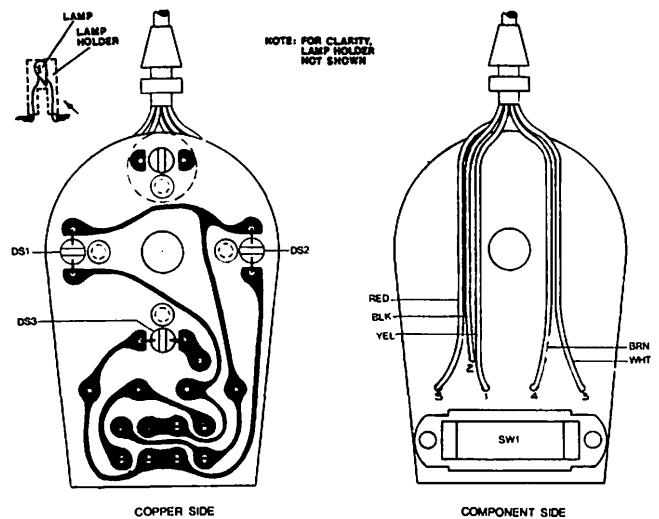

Figure 7. Control Unit Components.

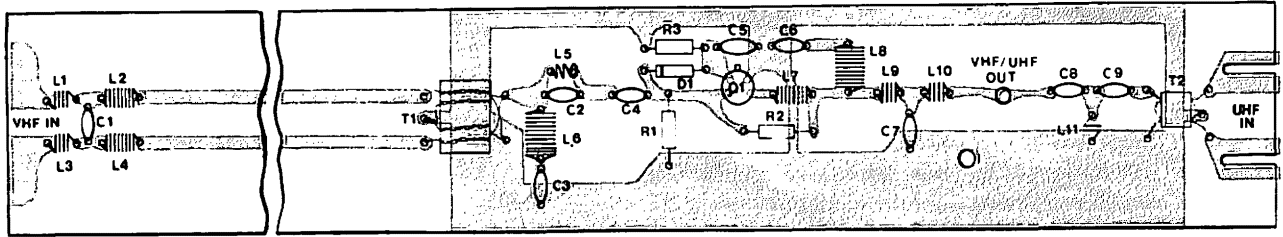

Figure 8. Amplifier Components.

Troubleshooting

Symptom

Antenna will not rotate; direction indicator lamps do not light; (120 VAC operation only)

Antenna will not rotate; direction indicator lamps do not light; (12 VDC operation only)

Antenna rotates slowly; direction indicator lamps light dimly; (120 VAC operation only)

Antenna will not rotate; direction indicator lamps light properly

Antenna at end stop; will not rotate

Antenna rotating in wrong direction; CW direction indicator arrow lights when control switch is pressed on left side and CCW direction indicator arrow lights when control switch is pressed on right side

Weak picture; no noticeable difference in picture when antenna is rotated, or when the 120 VAC and 12 VDC power cords are disconnected

Probable Cause

- AC power cord disconnected
- Power Transformer T1 defective
- Power supply diodes D1, D2, D3, D4 (Two or More) defective
- Control wire No. 4 or 5 open
- Switch SW1 defective

- DC power cord disconnected
- Fuse in DC power cord open
- Power supply diode D6 defective
- Switch SW1 defective

- Power supply diode(s) D1, D2, D3, or D4 defective

- 3-wire rotator cable open or incorrectly connected
- Defective motor
- Defective end stop switch

- End stop switch defective
- End stop diodes D1 or D2 defective

- Control cable connections 1 and 3 reversed

- Defective amplifier transistor Q1
- Open connection between antenna and amplifier
- Open or shorted coaxial lead-in cable
- Shorted or open amplifier coaxial wrap-around cable inside antenna housing.
- Defective power supply

NOTE: With amplifier and power supply

Symptom

Loss of color or snowy picture; (Channel 6 only)

Probable Cause

properly connected, voltage between L1 in power supply and ground should be approximately 11 volts DC during non-rotating operation. During rotation, this voltage may decrease slightly. During 12 VDC battery operation, if the battery is simultaneously being charged, this voltage may increase by several volts. A voltage of 16 volts or higher indicates a defective transistor or an open connection between power supply and amplifier. Very low or zero voltage may indicate a shorted C1, C2, C3, C4, or C5 capacitor, shorted coaxial cable, or short on amplifier board.

a. Amplifier coil L5 improperly adjusted
NOTE: FM trap coil L5 was carefully adjusted at the factory. Normally it should require no further adjustment. If adjustment is necessary, L5 should be spread or compressed until the first FM trap null occurs at 96 MHz. 88 MHz will then occur outside of FM trap with nominal gain of 21 dB. (This adjustment should be made only by qualified service technicians using RF sweep equipment and crystal markers.)

Information furnished by RCA is believed to be accurate and reliable. However, no responsibility is assumed by RCA for its use; nor for any infringements of patents or other rights of third parties which may result from its use. No license is granted by implication or otherwise under any patent right of RCA. RCA retains the right to make changes in this product at its discretion as may be periodically required.

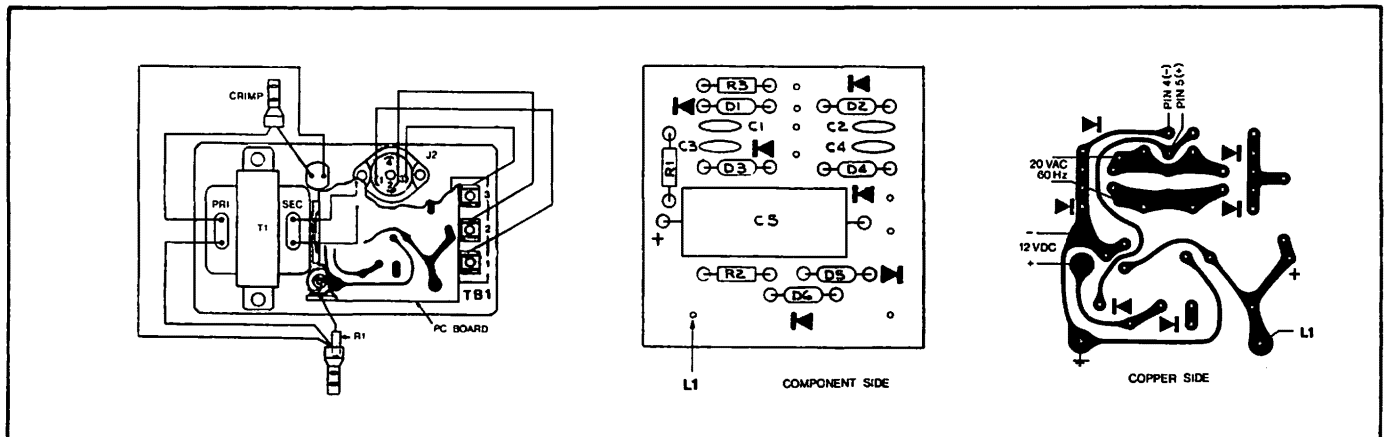

Figure 9. Power Supply Components.

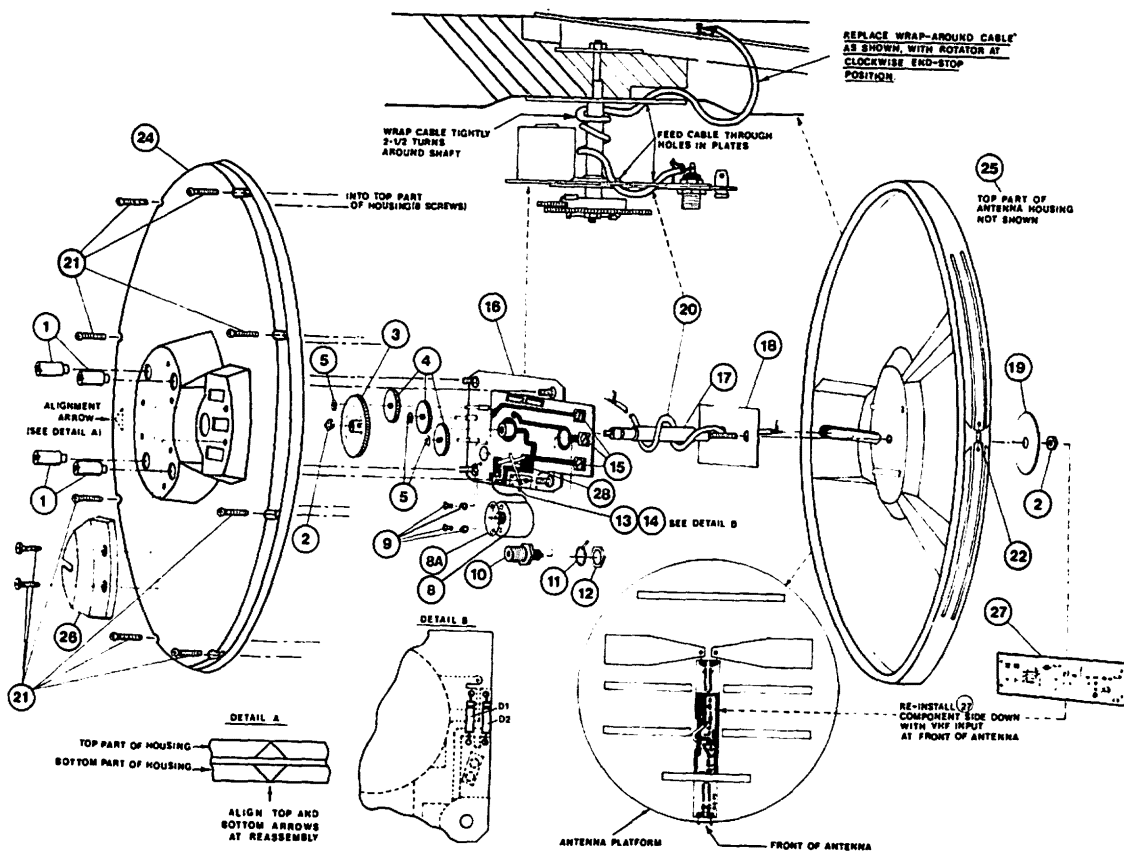

Figure 10. Antenna System Components.

Replacement Parts

Symbol	Stock No.	Description
POWER SUPPLY		
(Fig. 5)	742939	Power Supply, complete
C1,2,3,4,6	740775	2000 pF 500 V ceramic
C5	742941	330 uF, electrolytic
D1 to D6	231669	Diode 1N4003
J2	742940	Connector, 5-pin, chassis
J3	741819	Connector, 2-pin (DC)
L1	740739	Coil, RF choke
R1	502515	1.5 Meg, 5% 1/2 W
R2	502027	27 Ohms, 5% 1/2 W
R3	502147	470 Ohms, 5% 1/2 W
R4	502047	47 Ohms, 5% 1/2 W
T1	743404	Transformer, Power
TB1	740740	Terminal Board Ass'y, with 3 screw connectors
	245347	Strain Relief, power cord
	246608	AC Power Cord
	742937	DC Power Cord
AMPLIFIER		
(Fig. 8)	741244	Amplifier, complete
C1,8,9	423553	3 pF, 50 V ceramic
C2,4	423283	100 pF, 10% 50 V ceramic
C3,7	740984	10 pF, 50 V ceramic
C5	245268	1000 pF, 50 V ceramic
C6	423285	2000 pF, 50 V ceramic
D1	741100	Diode, 1S953
Q1	740727	Transistor, 2SC1424
R1	227741	560 Ohms, 5% 1/2 W
R2	108866	2200 Ohms, 5% 1/2 W
R3	108861	100 Ohms, 5% 1/2 W
CONTROL UNIT		
(Fig. 5)	742936	Control Unit, complete
DS1,2,3	740746	Lamp, Indicator
SW1	740743	Switch, Control
	742938	Lens, Indicator
	742969	Control Cable, with plug
ANTENNA UNIT		
22 (R1)	502136	Resistor, antenna termination, 360 Ohms, 1/2 W, ± 5%
24	740747	Antenna Housing, bottom section
25	740748	Antenna Housing, top section

Symbol	Stock No.	Description
26	740749	Cover, Terminal Board
21		Screw, No. 8, self tapping, 7/8" lg
ROTATOR UNIT		
	742942	Rotator Drive Unit, complete (Items 1-5, 8-20)
1	740751	Insert, mounting
2	740752	Nut, self threading (2 per pkg)
3	742943	Gear, Drive, with spring finger contact
4	740754	Gear, Idler
5	740755	Washer, retaining (3 per pkg)
8	740756	Motor, with pinion, mounting screws and washers
8A	743405	Insulator, motor
9	740757	Screw and Washer, Motor Mtg (2 ea. per pkg)
10		Coaxial Connector, chassis
11		Washer, with solder lug
12		Nut, connector
13/D1	231669	Diode, CCW End Stop, 1N4003
14/D2	231669	Diode, CW End Stop, 1N4003
15	740758	Terminal, with screw and nut (3 per pkg)
16	742944	Gear Plate Ass'y, with PC board, and items 10,11,12,13,14,15,28
17	740760	Shaft, Drive
18		Plate, Support
19		Washer, fiber
20	740761	Cable, coaxial wrap-around
28	740762	Switch, End Stop
MISCELLANEOUS		
(Fig. 3)	742945	Bracket, Antenna Mast Mounting; includes: 4 screws (10-32 x 1/2" lg), 4 split lock washers, 1 U-bolt, 2 nuts
	740764	Leg, Mounting, hairpin type, set of 3
(Fig. 5)	10G221	VHF/UHF Band Separator
	5MS401	30' Prefabricated Coaxial/3-Wire Rotator Cable



SECTION X

DIAGRAMS

This section contains the following diagrams:

Figure	Title
10-1	12V DC Supply System, Overall Wiring Diagram
10-2	120/240V AC Supply System, Overall Wiring Diagram
10-3	Potable Water System
10-4	Plumbing Drainage System
10-5	Heater Piping Diagram
10-6	LP Gas Piping Diagram

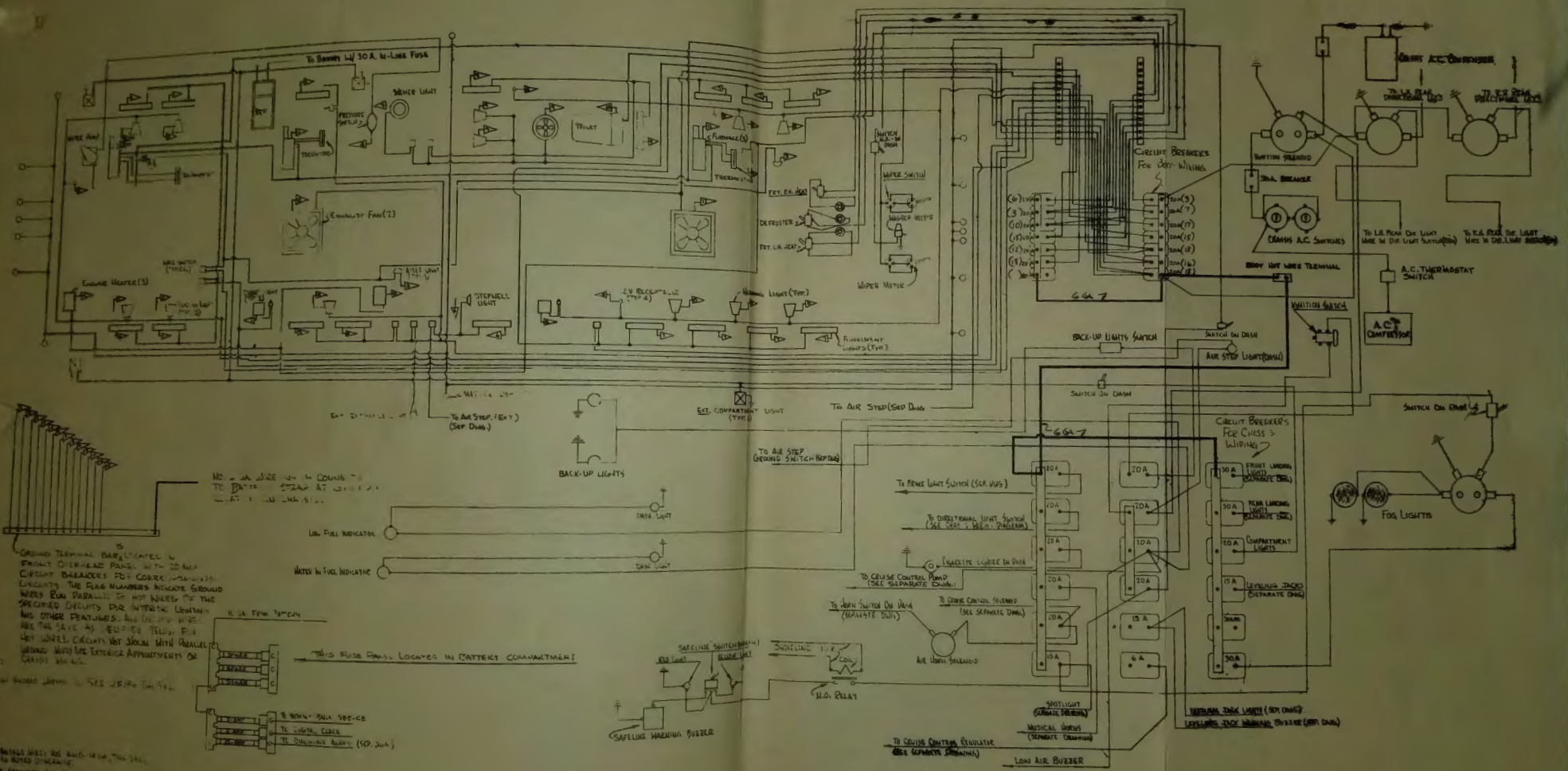
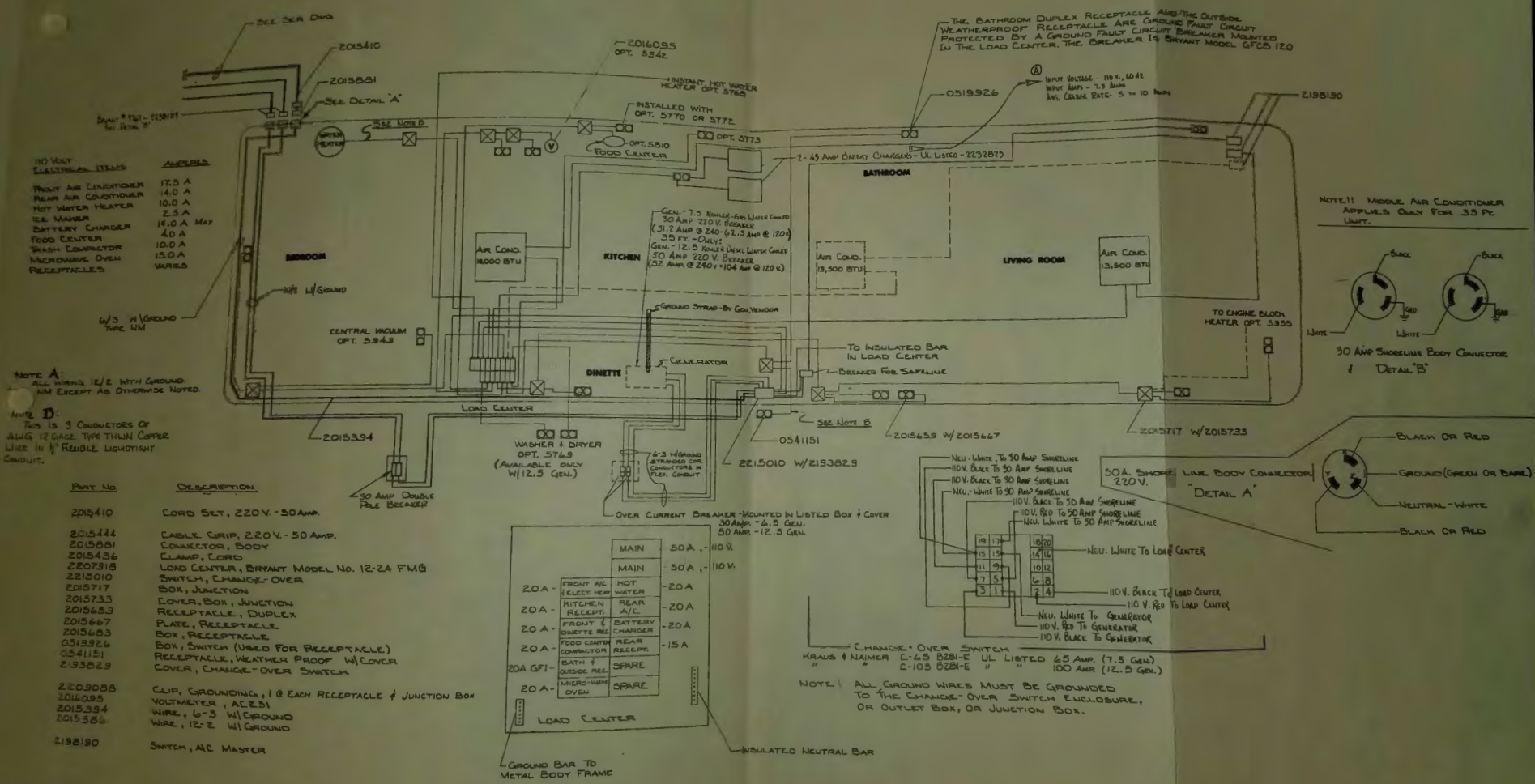

Figure 10-1. 12V Dc Supply System, Overall Wiring Diagram



- 110 VOLT ELECTRICAL ITEMS
- | ITEMS | AMPERES |
|-----------------------|------------|
| FRONT AIR CONDITIONER | 17.5 A |
| REAR AIR CONDITIONER | 14.0 A |
| HOT WATER HEATER | 10.0 A |
| ICE MAKER | 2.5 A |
| BATTERY CHARGER | 15.0 A MAX |
| FOOD CENTER | 4.0 A |
| WASH DRYER | 10.0 A |
| MICROWAVE OVEN | 15.0 A |
| RECEPTACLES | VARIES |

NOTE A: ALL WIRES 1/2" WITH GROUND WIRE EXCEPT AS OTHERWISE NOTED

NOTE B: THIS IS 3 CONDUCTORS OF AWG 12 GAUGE TYPE THHN COPPER WIRE IN 1/2" REBIL LIGHTNING CONDUIT.

PART NO.	DESCRIPTION
2015410	LOAD SET, 220V - 50AMP.
2015444	CABLE GRIP, 220V - 50 AMP.
2015661	CONNECTOR, BODY
2015436	CLAMP, LOAD
2207318	LOAD CENTER, BRYANT MODEL NO. 12-2A FMG
2215010	SWITCH, CHANGE-OVER
2015717	BOX, JUNCTION
2015733	COVER, BOX, JUNCTION
2015653	RECEPTACLE, DUPLEX
2015667	PLATE, RECEPTACLE
2015653	BOX, RECEPTACLE
0519326	BOX, SWITCH (USED FOR RECEPTACLE)
0541151	RECEPTACLE, WEATHER PROOF W/COVER
2193823	COVER, CHANGE-OVER SWITCH
2203088	CLIP, GROUNDING, 1 @ EACH RECEPTACLE & JUNCTION BOX
2016095	VOLTMETER, AC 251
2015394	WIRE, 6/3 W/GROUND
2015384	WIRE, 12-2 W/GROUND
2198190	SWITCH, AC MASTER

LOAD CENTER	RATING	VOLTAGE
MAIN	50A	110V
MAIN	30A	110V
20A	FRONT AC	-20A
20A	REAR AC	-20A
20A	FRONT & REAR WATER HEATER	-20A
20A	FRONT & REAR BATTERY CHARGER	-20A
20A	FRONT & REAR DINETTE REC.	-20A
20A	FOOD CENTER REAR CONDUCTOR	-15A
20A	BATH & OUTSIDE REC.	SPARE
20A	MICRO-WAVE OVEN	SPARE

NOTE 11: MIDDLE AIR CONDITIONER APPLIES ONLY FOR 35 FT. UNIT.

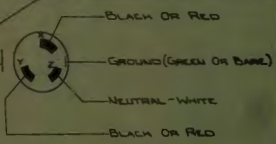
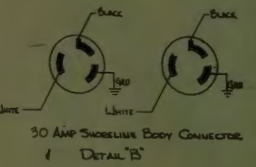
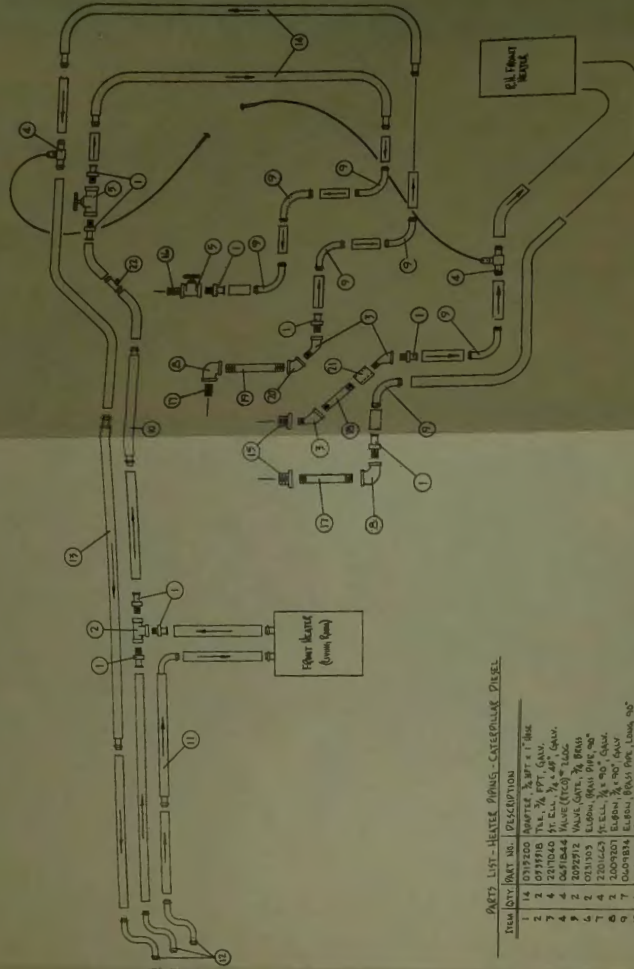

Figure 10-2. 120/240V AC Supply System, Overall Wiring Diagram



PARTS LIST - HEATER PIPING - CATERPILLAR DIESEL

ITEM	QTY	PART NO.	DESCRIPTION
1	14	0317200	WASHER, 3/8" x 1/8"
2	2	0979910	NUT, 3/8" PPT, GALV.
3	4	0979910	WASHER, 3/8" x 1/8", GALV.
4	4	0541844	NUT, 3/8" PPT, GALV.
5	2	2029212	WASHER, 3/8" x 1/8"
6	2	0313033	LOCKWASHER, 3/8" x 1/8"
7	4	2303625	WASHER, 3/8" x 1/8", GALV.
8	4	2303625	WASHER, 3/8" x 1/8", GALV.
9	7	0401834	WASHER, 3/8" x 1/8"
10	4	0314049	PIPE, STEEL, 1/2" DIA., 1/8" THICK
11	3	0317119	PIPE, IRON, HEATING SYSTEM, INTERMEDIATE
12	1	0317119	PIPE, IRON, HEATING SYSTEM, INTERMEDIATE
13	1	0317119	PIPE, IRON, HEATING SYSTEM, INTERMEDIATE
14	2	0493249	TUBING, COPPER, 1/2" DIA., 1/8" THICK
15	2	2009082	PIPE, BRASS, 1/2" DIA., 1/8" THICK
16	2	2009128	PIPE, BRASS, 1/2" DIA., 1/8" THICK
17	2	2009128	PIPE, BRASS, 1/2" DIA., 1/8" THICK
18	1	2009128	PIPE, BRASS, 1/2" DIA., 1/8" THICK
19	1	2009128	PIPE, BRASS, 1/2" DIA., 1/8" THICK
20	1	2009128	PIPE, BRASS, 1/2" DIA., 1/8" THICK
21	1	2009128	PIPE, BRASS, 1/2" DIA., 1/8" THICK
22	1	0317023	PIPE, IRON, HEATING SYSTEM, INTERMEDIATE
23	1	0317023	PIPE, IRON, HEATING SYSTEM, INTERMEDIATE

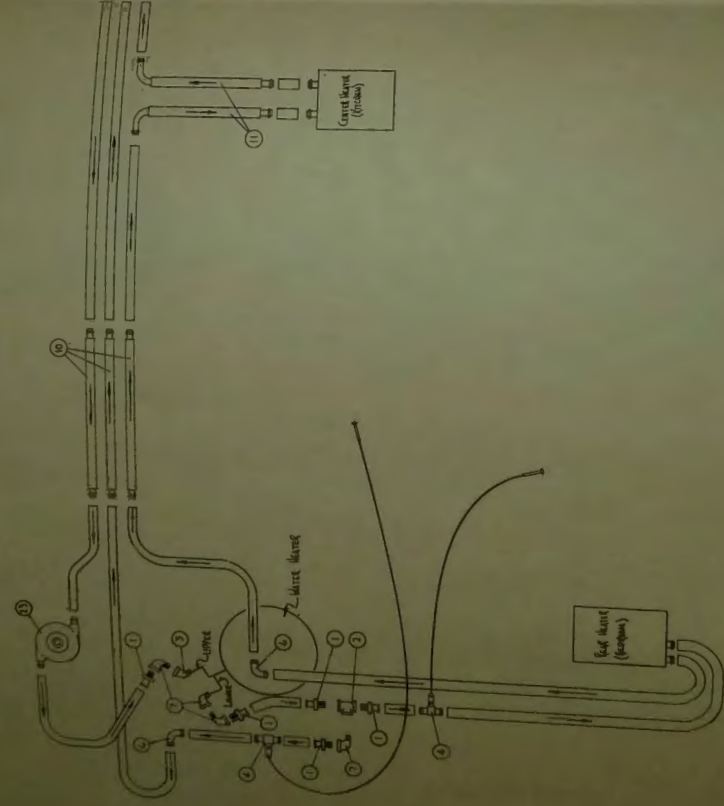
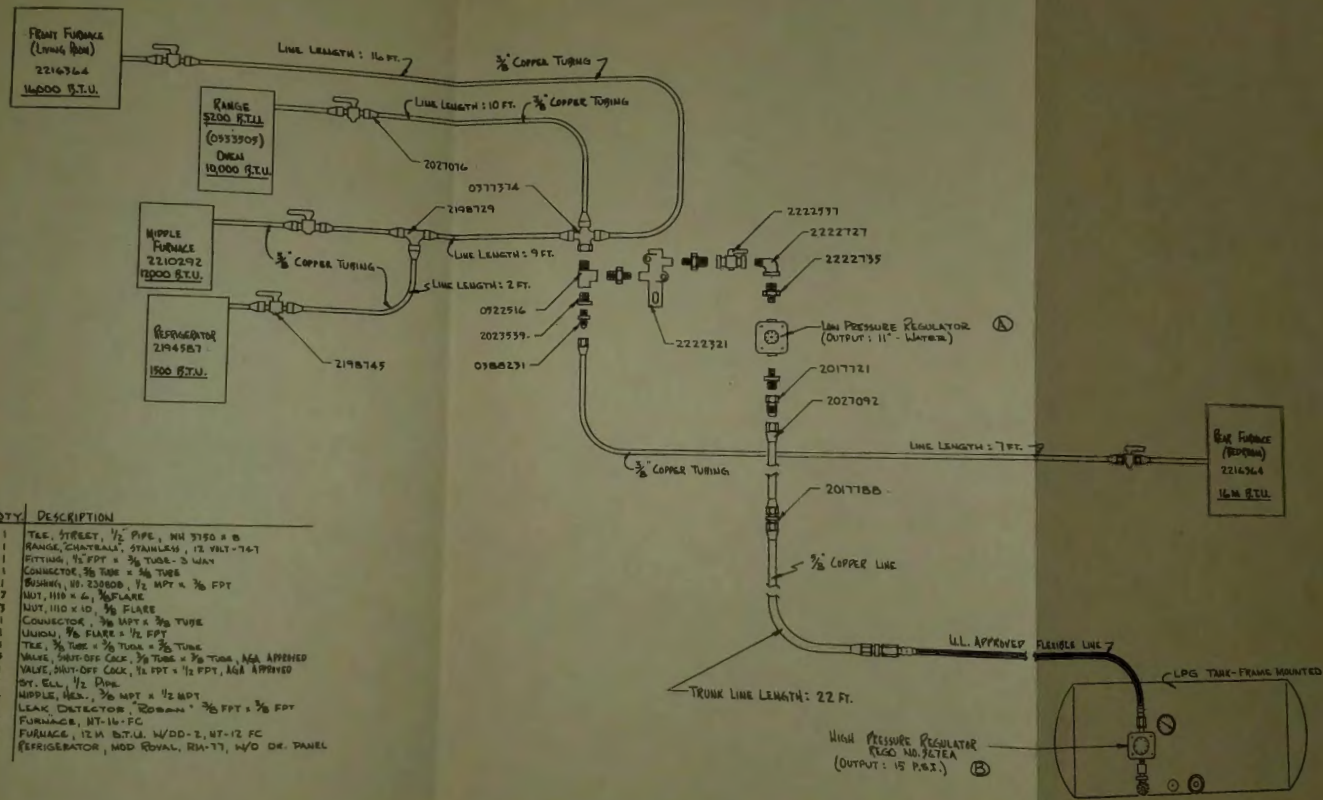

Figure 10-5. Heater Piping Diagram



PART No.	QTY.	DESCRIPTION
0922516	1	TEE, STREET, 1/2" PIPE, MH 3150 x B
0833907	1	RANGE, CHATRAUL, STAINLESS, 12 VLT-747
0317374	1	FITTING, 1/2" FPT x 3/8" TUBE-3 WAY
2017788	1	CONNECTOR, 3/8" TUBE x 3/8" TUBE
2023539	1	BUSHING, HD. END, 1/2" NPT x 3/8" FPT
2027016	17	NUT, 110 x 4, 3/8" FLARE
2027092	3	NUT, 110 x 10, 3/8" FLARE
0388231	1	CONNECTOR, 3/8" NPT x 3/8" TUBE
2017721	1	UNION, 3/8" FLARE x 1/2" FPT
2198729	1	TEE, 3/8" TUBE x 3/8" TUBE x 3/8" TUBE
2198745	5	VALVE, SHUT-OFF COCK, 1/2" TUBE x 3/8" TUBE, AQA APPROVED
2222577	1	VALVE, SHUT-OFF COCK, 1/2" FPT x 1/2" FPT, AQA APPROVED
2222727	1	BT. ELL, 1/2" PIPE
2222735	4	MIDDLE, A.S., 3/8" NPT x 1/2" NPT
2222321	1	LEAK DETECTOR, "ROBMAN" 3/8" FPT x 3/8" FPT
2216364	2	FURNACE, MT-16-FC
2210292	1	FURNACE, 12 M B.T.U. W/DD-2, MT-12 FC
2194987	1	REFRIGERATOR, MOD ROVAL, RH-77, W/O DR. PANEL

NOTE: ALL TUBING IS TYPE-"L" SOFT COPPER
ALL FITTINGS ARE FLARE-TYPE BRASS

Figure 10-6. LP Gas Piping Diagram

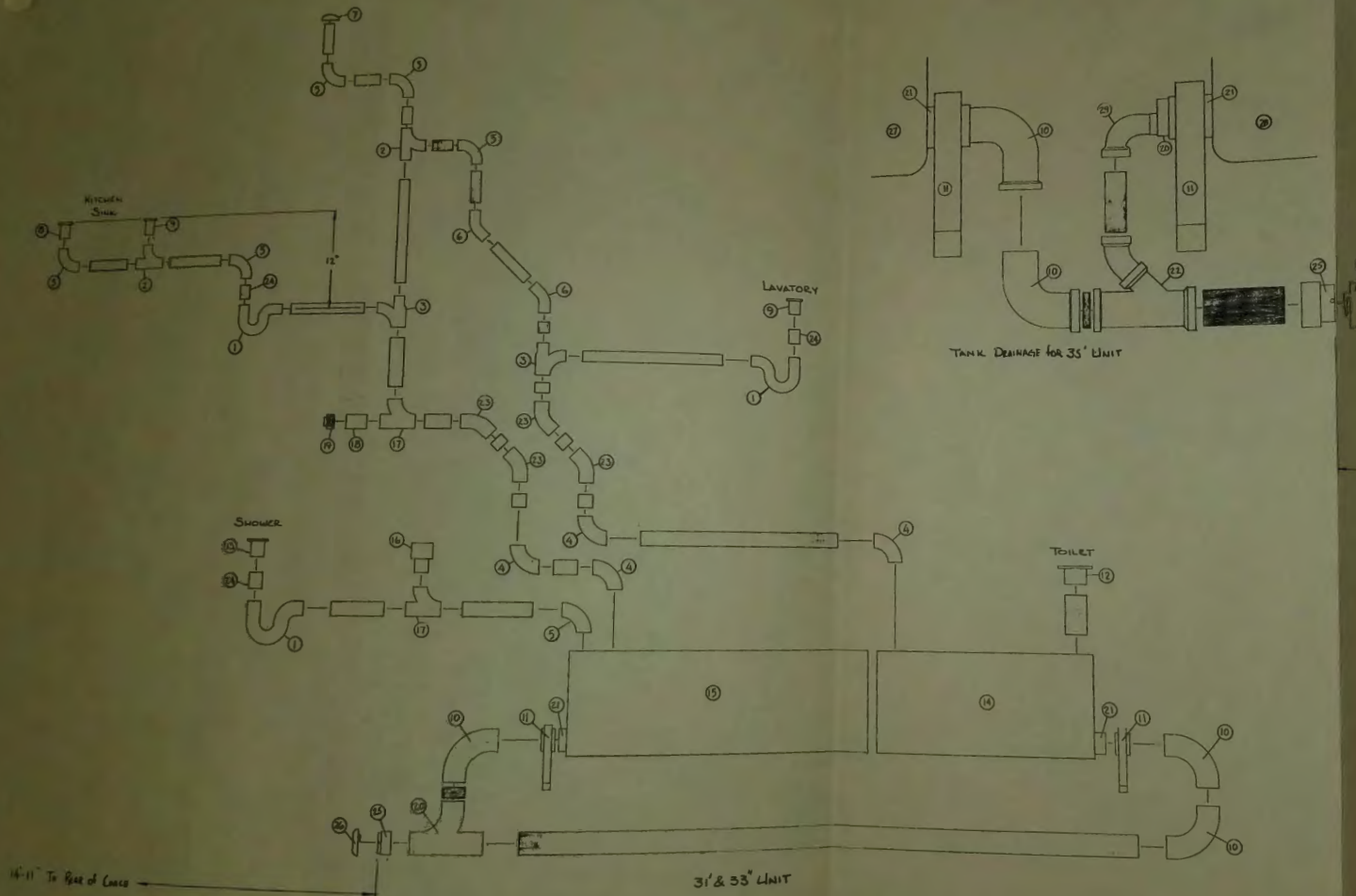

Part Number	Item	Qty.	Description
2017466	1	3	1 1/2" PTrap Hub x Hub Removable
0417818	2	2	1 1/2" Sanitary Tee H x H x H
0218421	3	3	2" x 1 1/2" Sanitary Tee H x H x H
0235277	4	4	2" x 90° Long Turn Ell
0417826	5	6	1 1/2" x 90° Long Turn Ell
0218480	6	3	1 1/2" x 45° Long Turn Ell
2017401	7	1	Vent Cap
0218109	8	1	1 1/2" Tray Plug Adapter PAPERK Spigot
0218192	9	2	2" x 90° St. Ell. L.T.L.
0218406	10	2	Dump Valve Assembly
2106027	11	1	Closest Flange 3" PPT
2017218	12	1	Adapter Tray Plug 1 1/2"
2017507	13	1	Tank Waste Holding Toilet
0218108	14	1	Tank Waste Holding Sink
0218105	15	1	Vent Check #110 NSF Approved
2211589	16	2	Tee 2" PPS-2152 L.T.T.Y.
2300024	17	1	Adapter Fitting Closetout 80296
2218025	18	1	2" Plug Ass. CS-3023
2210714	19	1	Tee 2" 5 x 5 x 5 L.T.T.Y.
2215308	20	2	Adapter 2" Male
2199041	21	1	30" Duct Only - Tee 3" x 3" x 1 1/2" L.T.T.Y.
208	22	3	Elbow 2" x 45°
2106044	23	3	Coupling O-Ring #3001
2017038	24	1	Adapter Bayonet Dump Valve
2106721	25	1	Cap & Chain 2" Bayonet Dump Valve Assy.
2207081	26	1	Tank Waste Holding Toilet 3407
2207077	27	1	Tank Waste Holding Sink 3407
2210730	28	1	1 1/2" 90° St. Ell. L.T.L.
2210730	29	1	All piping is ABS-TI-02 NSF-DVY ASTM-D843-BCH-60

All fittings are ABS 1
NSF-DVY except as noted
Holding tanks are JAPWD listed
Fiberglass construction

15'-2" To Rear of Cabin.

14'-11" To Rear of Cabin

3' & 3 1/2" UNIT

Figure 10-4. Plumbing Drainage System

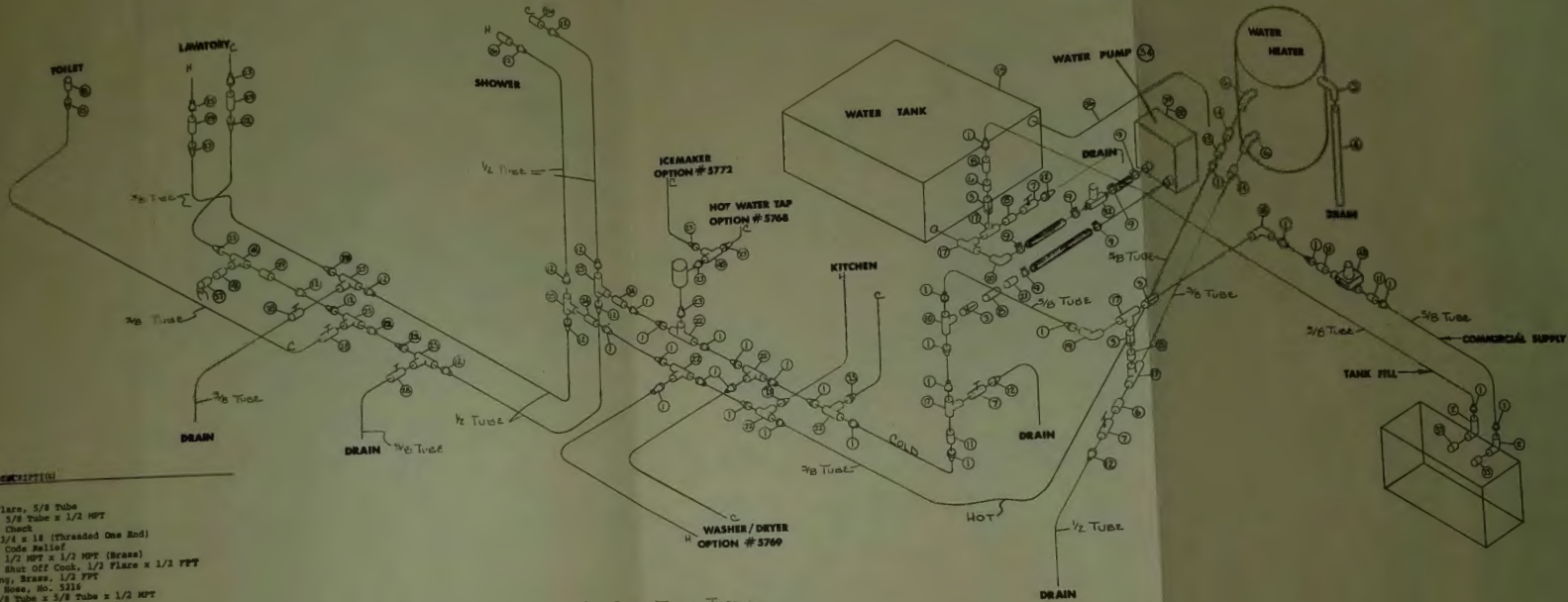

PART NO.	REQ.	QTY.	DESCRIPTION
2027003	1	20	Nut, Flare, 5/8 Tube
2027004	2	2	Elbow, 5/8 Tube x 1/2 MPT
0923009	3	4	Valve, Check
2000009	4	1	Pipe, 1/4 x 18 (Threaded One End)
2015005	5	1	Valve, Code Relief
2150035	6	1	Elbow, 1/2 MPT x 1/2 MPT (Brass)
2150035	7	2	Valve, Shut Off Cool, 1/2 Flare x 1/2 FPT
2150037	8	3	Coupling, Brass, 1/2 FPT
2017001	9	4	Clamp, Hose, No. 5216
2000032	10	1	Tee, 5/8 Tube x 5/8 Tube x 1/2 MPT
2017003	11	1	Connector, 1/2 MPT x 5/8 Tube
2027002	12	20	Nut, Flare, 1/2 Tube
2194004	13	4	Nut, Switch, Forged - 5/8 x 5/8
2190006	14	1	Connector, Male, 5/8 Tube x 1/2 Tube
2194006	15	1	Tank, Plastic, Potable Water
2190042	16	1	Tee, 5/8 Tube x 5/8 Tube x 5/8 Tube
2190038	17	1	Tee, 5/8 Tube x 1/2 MPT x 5/8 Tube
2025029	18	2	Bushing, Pipe, 1/2 MPT x 3/8 FPT
2027015	19	2	Insert, Straight, 3/8 MPT x 1/2 Barbed
2026037	20	2	Reducer, Galv., 1/2 FPT x 3/4 FPT
2190008	21	2	Tee, 5/8 Tube x 5/8 Tube x 1/2 Tube
2017013	22	2	Tee, 5/8 Tube x 5/8 Tube x 3/8 Tube
2027016	23	2	Nut, Flare, 3/8 Tube
2017023	24	2	Union, 1/2 FPT x 3/8 Tube
2017047	25	5	Tee, 1/2 Tube x 1/2 Tube x 1/2 MPT
2026444	26	2	Connector, 3/8 MPT x 1/2 Tube
0400442	27	1	Faucet, Shower
2017250	28	3	Valve, Stop, 1/2 FPT x 3/8 Tube
0510250	29	2	Union, 1/2 Tube x 3/8 Tube
0514485	30	1	Faucet, Bathroom
0148211	31	1	Connector, 3/8 MPT x 3/8 Tube
2014926	32	1	Guard, Pump
2010491	33	2	Fitting, Round, 1/2 FPT x 3/4 FCHT w/Plug
2014913	34	1	Pump, Water
0524504	35	1	Faucet, Kitchen
0322405	36	1	Hose, Flexible
07A	37	1	Switch, Pressure, Pump Control
2200450	38	1	Flare, 3/8 - 16 x 1/2 Long
2200000	39	1	O-Ring Seal
2211372	40	1	Tee, 3/8 Tube x 3/8 Tube x 1/4 MPT
2200410	41	1	Adaptor, 1/4 FPT x 3/8 - 16 Straight TMD
2021451	42	1	Regulator 00250

Figure 10-3. Potable Water System



AWNINGS

The awning attached to your coach is designed for simplicity of operation and long-term use. To open the awning, refer to the installation sequence, shown in figure 1, and proceed as follows:

OPEN AWNING

1. Loosen clamp wheels and tilt inward, as shown in A.
2. Completely unroll awning by pulling the tab toward you with the hook. Fold and tuck the tab into the loop nearest the roller on the underside of the awning as shown in B. Now move be-

neath the awning and proceed with step 3.

3. Release snap stud on main arm and extend the awning until the second hole is engaged, as shown in C.

4. Referring to D, raise awning to desired height by extending main arm. Release snap stud and push outward on underside of roller-release snap stud so it will engage at desired height. Lean, so that body weight — rather than arm strength — carries out this step.

5. For a "short" awning, refer to E and unroll awning two-thirds of its length. Place spring arm claw on roller shaft; do not release snap stud. Do not release the tab until spring arm is secured. Fold tab and tuck into middle loop.

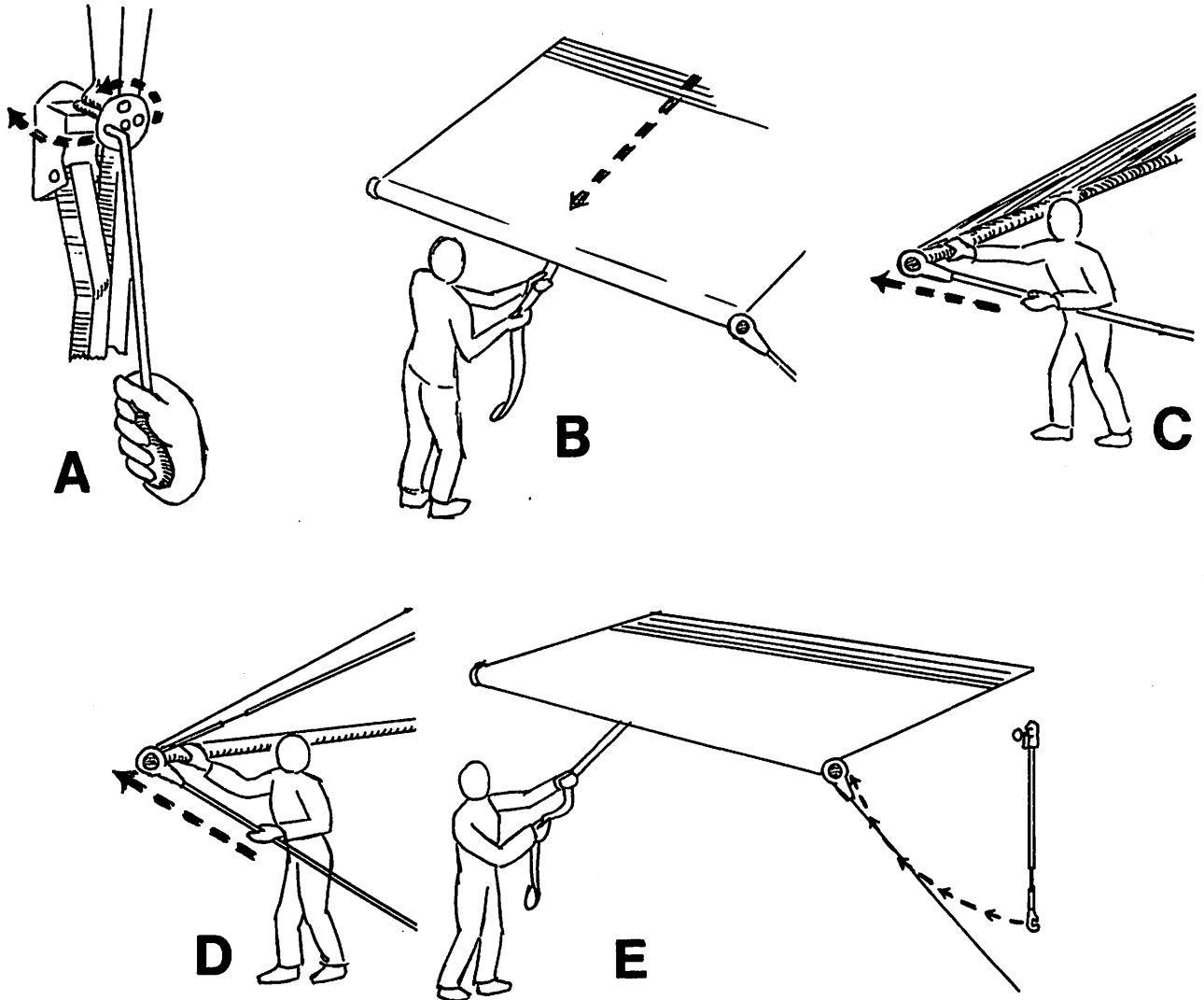

Figure 1. Awning Installation Sequence



CLOSE AWNING

1. Release snap stud on spring arm. Remove spring arm claws from roller shaft and place them on claw pins (on inside of main arms). This "scissors-action" guides the main arms evenly and upward.
2. Release snap stud on main arms and lower awning.
3. While facing the awning, and holding the tab loosely in one hand, give the roller an upward push until the spring takes over. Control the roll-up speed by holding the tab until all but 6" of fabric has rolled up. Release tab and allow awning to roll free for these last few inches and snap closed.

NOTE

The tab must be spiraled around the roller to prevent a loose roll and the bunching-up of fabric.

4. Tighten clamp wheels before moving vehicle.
5. Observe if the roll-up is even and in-line with clamps. If not, then unroll and give roller a slight push toward the direction required to line up the roller. If you wish to have the awning roll up more in either direction spiral the pull tab in that direction.

FABRIC CARE

The awning fabric is Acrilan, which cannot rot or mildew. Since it is woven, you will be cooler in its shade because of air circulation through the weave. A regular cleaning with a dry, medium-bristle brush, or a hose rinse, is usually sufficient to remove most dust and dirt. For more stubborn stains, use a mild solution of pure soap (Ivory or Lux, for example) and Borateem, applied with a sponge or a soft brush. Rinse well after and repeat if necessary. NEVER use a strong detergent (such as 409 or Fantastic) as these can remove the chemical impregnation that keeps the fabric water-resistant.

Acrilan can be rolled up wet, if necessary, but unroll to dry as soon as possible. Acrilan is a completely synthetic material. As such, it cannot support mildew or other plant growth. However, mildew can form on the organic material that lands

on the awning over a period of time, such as pollen and plant spores, grain dust and other airborne plant material. Although this mildew will not damage fabric structurally, the resulting stain is unattractive and extremely difficult to remove. To reduce the chances of this type of stain formation, keep your awning as clean and dry as possible, hosing it down frequently between seasonal washing.

WATER LEAKS

The awning seams are stitched and the Acrilan weave will normally re-form around the needle holes to seal them. Depending on how much you use the awning, this process may take a bit longer in some cases. If so, apply a commercial seam sealer (available from canvas or trailer suppliers) or plain paraffin wax to the top of the seams.

If the body of the fabric seems to lose its water repellency after a time (this can be caused by harsh industrial atmosphere or strong cleaning agents) you can restore it with a commercial water-repellent such as Gard, Scotch Guard or Rain Check, which are locally available. However, soap or chemical residues can "wet" the fabric so that it only appears unable to repel water in some spots. So, before you renew the fabric, rinse it thoroughly and test the water-repellency again after it is dry.

Although your Zip-Dee awning requires less maintenance than an ordinary awning, a little care will keep it in top shape. At the end of each season, check and tighten any loose bolts or screws. Replace missing parts with factory-replacements only.

Ensure continued ease of operation and prevent corrosion by cleaning all accessible hardware with alcohol and protect with a coating of auto wax. Use a spray silicone lubricant for inaccessible places. Extend the main and spring arms as far as possible to wipe off sand and dirt that can clog and score the aluminum.

Avoid leaving the awning open during storms or sudden gusts of wind to prevent damaging the arms.



CLOSED-CIRCUIT TV SYSTEM (CCTV)

The CCTV system includes the following items:

- CCTV Camera, figure 1, located in the rear bulkhead;
- CCTV Monitor/TV, figure 2, located on the upper bulkhead panel above the driver;
- VHF/UHF tuning and volume controls, located on a panel above and to the left of the driver.

CCTV CAMERA

The CCTV camera, figure 1, is designed to focus from about two feet to infinity with the standard $f/1.6$ lens supplied with the unit. The controls on the rear of the unit are not intended for user-alteration and are factory-preset for optimum performance. The POWER ON/OFF switch is left in ON position and camera power is controlled via the ON-OFF switch on the CCTV monitor.

TV MONITOR

The TV monitor, figure 2, includes the ON-OFF switch which applies power to the remote CCTV

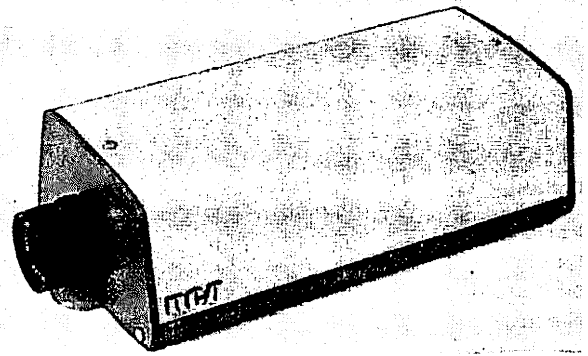

Figure 1. CCTV Camera

camera and to the monitor itself, which may be used as a conventional TV set, via the tuner and volume controls above the driver; or as a TV monitor, as desired.

MAINTENANCE

The equipment used in the CCTV System is highly sophisticated and is not designed for user maintenance. Repairs on this type of equipment should be performed by a qualified TV technician or manufacturer's service center.

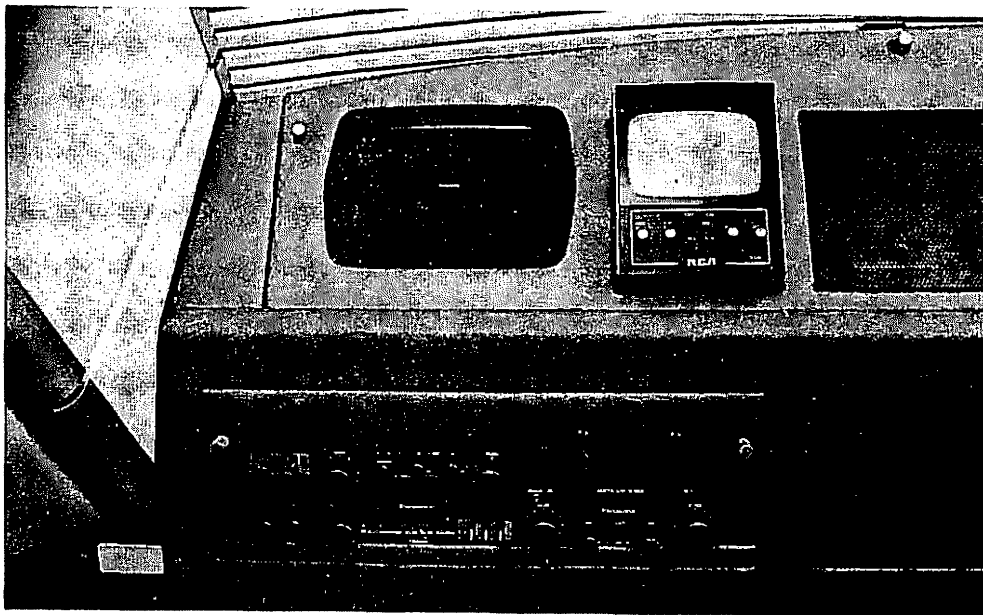

Figure 2. CCTV Monitor



DIGITAL CLOCK AND CHIME ALARM

The digital clock and the chime alarm interconnect with an integrated ac-operated receiver unit in the bedroom; two plug-in stereo headphone jacks and associated speaker volume controls on the bedroom and living area walls; two radio/chime alarm selector switches; speaker and power input wiring from the 12-volt dc in-dash radio system; and miscellaneous coach wiring and control relays.

The system is wired so that the integrated receiver (bedroom) audio output is automatically connected to the coach speaker system (and headphone jacks), simultaneously disconnecting the power and speaker output from the 12-volt dc radio. Turning off the ac supply, or the alarm, automatically restores 12-volt dc radio operation.

OPERATION

Operation of the various alarm features depends on the setting of the digital clock alarm timing feature; and the position of the two alarm selector switches: RADIO TIMED-OFF-RADIO CONT. and

RADIO TIMED-CHIME TIMED-OFF.

Operate the alarm features as follows:

1. Set digital clock to desired time.
2. To select chime alarm, set the RADIO TIMED-CHIME TIMED-OFF switch to CHIME TIMED position.
3. To select the radio alarm, set both switches to RADIO TIMED position.
4. To activate both the chime and the radio features, set the first switch to CHIME TIMED; set the second switch to RADIO TIMED.
5. To shut off either the chime or the radio, set the corresponding switch to OFF position.
6. To operate the bedroom radio normally, set the RADIO TIMED-OFF-RADIO CONT. switch to RADIO CONT. position.

Note that operation of the integrated receiver from the ac supply automatically disconnects the 12-volt dc radio system from speakers and the dc supply. If the 12-volt dc radio system appears to be inoperative, first check to see that the alarm circuits are not activated, or that ac is present.



INSTANT HOT WATER HEATER

The instant hot water heater is installed on the left side of the galley sink, as shown in figure 1. The unit includes a 120-volt ac 2-quart electric under-cabinet water heater and push-lever operated faucet. Power to the heater is supplied via the circuit-breaker panel in the rear closet.

User-maintenance is not recommended; refer repairs to an authorized service center.

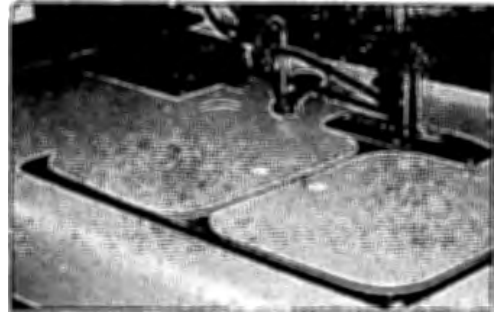

Figure 1. Instant Hot Water Heater



ICE-MAKER

The ice-maker, figure 1, is designed to provide a continuous automatic supply of ice cubes. It will operate unattended providing that the water supply line is open and the ac power is applied to the unit.

OPERATION

The power on-off switch is located on the front grillework. When the ice cube supply is full, the ice-making mechanism shuts off automatically. However, the refrigeration system continues to operate to prevent the prepared ice cubes from melting. When removing cubes, do not use a sharp instrument to separate the cubes that are frozen together or the interior may be damaged.

Note that the ice-maker may supply small cubes the first time that it is used. This is due to accumulated air in the water line and subsequent batches will be normal-sized;

If the machine is used only intermittently, empty the ice periodically (every week to 10 days) to ensure a fresh supply of cubes.

Do not clean the cabinet interior with solvent-type cleaners, abrasives, or other cleaners that might cause ice cubes to acquire a bad taste. The exterior should be cleaned with a furniture-type cleaner/polish. Clean condenser (behind grille) with a blower/vacuum at least 3 to 4 times each year, depending on usage.

SHUTDOWN — To shutdown the ice-maker, set power switch to off, shut off the water supply to

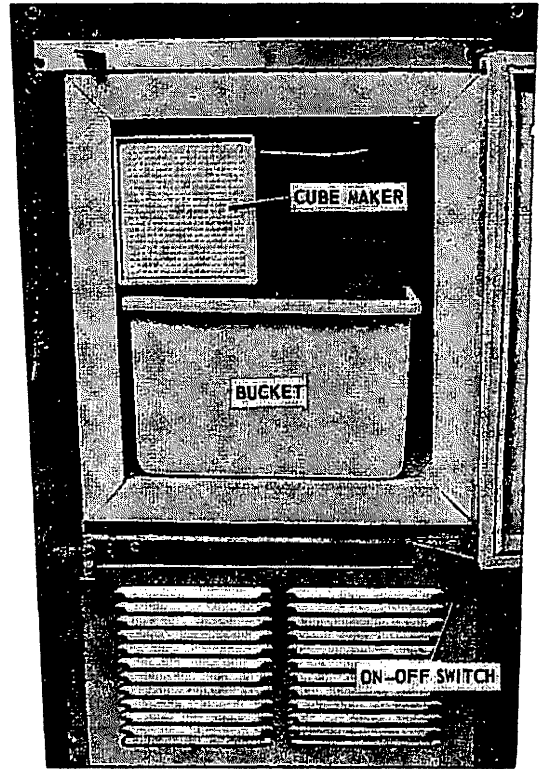

Figure 1. Ice-Maker

the unit, and remove all cubes. Leave the door slightly ajar for ventilation and to avoid accumulation of mold or bad odors.

MAINTENANCE

Other than periodic cleaning of grillework, condenser and interior, no other maintenance procedures are required. Refer to table 1 for a troubleshooting guide.

Table 1. Ice-Maker Troubleshooting Guide

Symptom	Possible Cause	Corrective Action
Water in bucket.	Machine is not level, water runs out of freezing mold into storage compartment or bucket.	Level ice-maker.
	Poor gasket seal, or door is slightly ajar because bucket is not pushed in far enough.	Correct gasket seal; remove obstruction.



Table 1. Ice-Maker Troubleshooting Guide (continued)

Symptom	Possible Cause	Corrective Action
Water in bucket (cont.).	Defective water valve switch.	Replace switch.
Ice sticks together.	Unit is not leveled.	Level unit properly.
	Faulty door seal.	Correct/replace door seal.
Defrosting occurs too often; or, cubes frosty on surface.	Poor door seal.	Correct/replace door seal.
	Chemical content of water differs in each locality, therefore, freezing point of ice differs.	Lower freezing temperature by turning temperature control (in rear of cabinet) one-quarter to one-half turn clockwise. Reverse procedure for a warmer setting.
Ice-maker freezes up.	Poor door seal.	Correct/replace door seal.
	Water splashing out of ice-maker mold into storage compartment or bucket.	Remove excess water.
	Slow leakage through electric solenoid valve.	Replace solenoid valve.
	Ejector blades are frozen-in and cannot eject cubes.	Defrost unit thoroughly.
	Switch in unit compartment may be set "off". Also, check power supply wiring.	Check switch; check electrical connections.
Ice-maker does not produce ice cubes.	Water supply is turned off.	Restore water supply.
	Unit is not installed level, but is tilted backwards, creating a frost build-up on the suction line.	Level unit properly.
Ice is too soft and wet.	Control setting too warm.	Adjust control one-quarter to one-half turn clockwise.
	Door not closing fully.	Correct/replace door gasket.
	Bucket is out too far.	Reposition bucket.
	Air is being blocked from entering grille.	Remove obstruction.



Table 1. Ice-Maker Troubleshooting Guide (continued)

Symptom	Possible Cause	Corrective Action
Ice-maker produces cubes continuously.	Shut-off arm switch is defective.	Replace switch.
	Shut-off arm switch is frozen in ice.	Remove cubes and defrost unit until arm moves freely.
Insufficient cube supply.	Temperature control is set too cold.	Turn control one-half turn counter-clockwise.
	Ice-maker not level.	Level unit properly.
	Fan motor not running.	Repair or replace fan motor.
	Condenser coil behind grille is dirty.	Clean coil.
Ice cube supply cloudy.	This is due to air being trapped in the water due to fast-freezing. This is not harmful.	None.
Too much water entering	Water valve switch is not adjusted properly.	Remove front cover and adjust screw.
Ejector blades frozen in cubes.	Too much water entering.	Adjust water valve switch. Remove front cover and adjust screws.
	Machine received a "double shot" of water; or cubes piled too high melted back into freezing tray.	Shut off machine for one hour.
Ice-maker won't eject cubes.	Ejector blades frozen into ice maker mold.	Defrost unit and remove some water from freezing tray.
	Limit switch is defective.	Replace limit switch.
	Too much water entering.	Adjust water valve switch.
Compressor inoperative.	No supply voltage to unit.	Check for ac supply to unit; reset circuit breaker.
	Unit is switched off.	Check that switch behind front grille is ON.
	Defective overload relay.	Replace overload relay.



Table 1. Ice-Maker Troubleshooting Guide (continued)

Symptom	Possible Cause	Corrective Action
Intermittent operation.	Defective switches.	Check action of water valve switch, holding switch and shut-off arm switch by depressing the small black button and listening for the switch-click. If there is no click, replace switch.
	Improper door seal.	Adjust hinges, realign door, or shim door gasket where required.
Noisy compressor.	Machine is not level.	Level unit properly.
	Defective compressor.	Replace compressor.
	Fan motor not operating.	Check for binding, obstruction, etc. Repair or replace, as necessary.
High-pitched or ringing noises.	Fan blade pitched wrong.	Stop unit, reach in and bend each fan blade one-quarter or one-half inch to the rear. This cuts the air at a different angle and should eliminate the noises.
	Copper refrigeration tube is touching cabinet and is vibrating.	Reposition components.
Compressor runs continuously.	Control is set too cold.	Use a warmer setting.
	Obstructed front grille preventing air from entering.	Remove obstruction.
	Condenser is dirty.	Clean condenser.
Ice-maker ejector motor runs but ejector blades do not operate.	Coupling is broken; or stripped gear in ejector motor.	Replace defective part(s).
Ice-maker ejector motor and ejector blades turn continuously.	Defective cold control	Replace control.
	Defective holding switch.	Replace switch.



INTEGRATED RECEIVER SYSTEM

The integrated receiver system mounted in the bedroom includes AM/FM/FM Stereo, 8-track record/play operation, and connections for cassette tape player/recorder and phonograph inputs.

OPERATION

Refer to the operating controls and indicators shown in figure 1 with the following procedures:

RADIO OPERATION —

1. Set Selector switch (6) to desired radio band, either FM, FM AUTO or AM.
2. Set power ON-OFF switch (16) to ON, which also lights up the dial panel.
3. Set tape monitor switch (10) to SOURCE.
4. Operate tuning control (7) to select desired radio station, as indicated by dial pointer (13).

NOTE

Keep the AFC switch (9) in OFF position until optimum tuning is done, then set to ON to lock-in station.

5. Set volume control (2) to desired level.
6. Set balance control (3) for best stereo effect.
7. Set loudness control (11) as required.
8. To shut unit off, set power ON-OFF switch to OFF.

Be sure that Mic-Mixing control (32) is set to MIN position when not in use.

FM STEREO RECEPTION — The FM STEREO indicator (8) will light up whenever the program is being broadcast in FM stereo, with the selector switch (6) in FM AUTO or FM position. The FM stereo effect will be heard only when FM STEREO indicator is lit AND the selector switch (6) is in FM AUTO position.

RECORDING FROM RADIO — Choose the program to be recorded, then proceed as follows:

NOTE

Check that the NOT READY indicator (19) is extinguished. If this indicator is lit, the FF button is depressed and must be released before recording can begin.

1. Operate the unit to select the desired radio program.

2. Depress pause button (26).

3. While pressing the record button (22) insert the tape cartridge into the tape slot (20). Note that the recording ON indicator (18) is lit and the pointers on the REC level meters (14, 15) are moving.

4. To start recording, release the pause button (26). To stop recording, depress the manual eject button (23). The record button (22) will return to the original position, the recording ON lamp (18) will extinguish and the tape will eject.

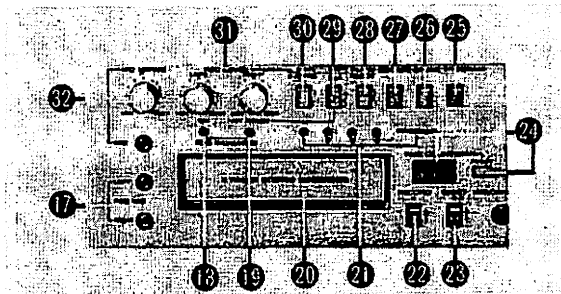
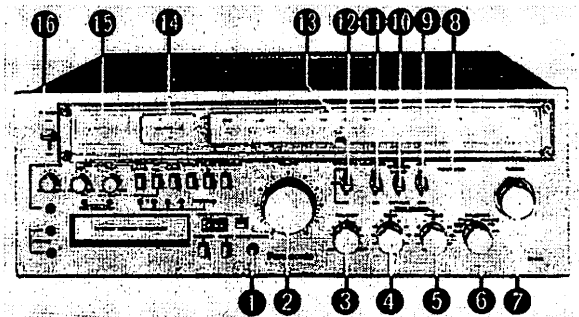

Figure 1. Integrated Receiver Unit

RECORDING FROM MICROPHONE — If a microphone is available for recording, proceed as follows:

1. Connect microphone to microphone jack(s) (17).
2. Set selector switch (6) to TAPE/MIC.
3. Repeat steps 2, 3 and 4 from the previous procedure.



NOTE

Do not leave microphone(s) connected when record feature is not in use. Also, to prevent howling (feedback from speakers) when monitoring from the microphone(s), either use a set of headphones, or turn the volume control (2) to minimum.

MAINTENANCE

User maintenance is not recommended. However, the record/playback/erase head, figure 2, may be cleaned, if done with care. This head, sensing poles and capstan shaft in the tape slot may accumulate dust and tape residue, causing poor or wavering sound, or incomplete erasure of previous recordings. This residue should be cleaned periodically (about every 100 hours of

playing time). Clean the surface of the head, sensing pole and capstan gently with a cotton swab moistened with alcohol; or by loading a special head cleaning tape cartridge into the tape slot.

CAUTION

Never bring a magnet or metal objects (screwdriver, for example) close to the heads or any part of the tape mechanism. This may cause costly damage to the recorder.

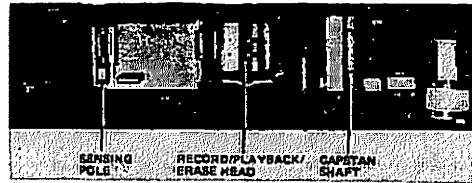

Figure 2. Cleaning Tape Head



INTERCOM SYSTEM

A three-station master-to-master intercommunication system links the driver, dinette and bedroom areas.

As shown in figure 1, each telephone-type handset includes two pushbutton station selectors, which may be depressed to contact one of the other stations with a beep-alert.



Figure 1. Typical Intercom Unit



LEVELING JACKS

Leveling jacks are located in each corner of the coach, as shown in figure 1. These are 12-volt dc electrically-operated hydraulic jacks, which are controlled directly at the driver's dashboard by a combination of FRT and REAR LEVELING switches and indicator lamps. The jacks are independently-operated, each has a corresponding audible, visual and "leveleze" signal (at the dash) to indicate that the jacks are down and the coach has been automatically leveled.

OPERATION

To operate the leveling jacks, air pressure must be up, then proceed as follows:

1. Set LEVELING MASTER switch to ON; note that LEVELING WARNING LIGHT SYSTEM indicators are lit (L.R., L.F., R.R., R.F.), indicating that all four jacks are down. (If ignition is ON, the alarm will also sound.)
2. When the coach is automatically leveled, the four LEVELING LIGHT SYSTEM indicators will be lit (L.R., L.F., R.R., R.F.),

CAUTION

If the jacks are not withdrawn before driving away, the audible alarm will sound and the WARNING LIGHTS will be lit.

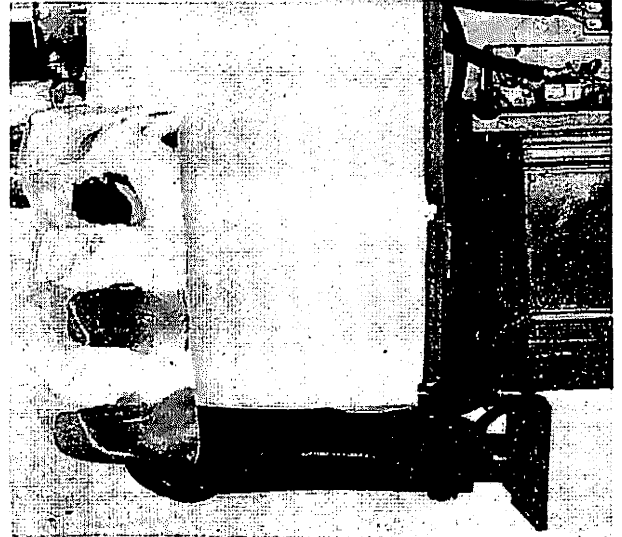

Figure 1. Typical Leveling Jack



LANDING LIGHTS

Recessed landing lights are located at the top front and rear roof sections and are controlled by operation of corresponding dashboard switches.

The FRONT LANDING LIGHTS and REAR LANDING LIGHTS switches are located on the lower right side of the dashboard.



MOTOR GENERATOR

The motor generator is designed for unattended operation and is located in the right front storage compartment. Unlike a dc-to-ac inverter, which electronically changes the dc battery voltage to an ac line voltage, the motor generator includes a dc motor which generates an ac output in much

the same manner as commercial electricity is produced. Because of this, the ac output is completely isolated from the dc source and provides an interference-free stabilized ac supply for operation of the CCTV system and/or the ice-maker unit.

User maintenance of this equipment is not recommended.



MICROWAVE OVEN

The microwave oven provides programmed microwave cooking and conventional "browning".

Cooking with microwaves is considerable different than cooking with a conventional oven. Do not use conventional metal pots or pans (frozen dinners may be cooked directly in the shallow aluminum tins, no more than 7/8-inch high). Use glass, ceramic, china, plastic or paper containers;

these are transparent to microwaves and allow food to heat quickly. Interior spatters, soiling or condensation are easily cleaned with a damp rag.

All operating controls and indicators are provided on a keyboard-type control panel, as shown in figure 1. All control cycles — microwaving, browning, temperature-monitoring, cycle timing — are selected by operating switches on this panel. Use figure 1, on the reverse side of this page, as an operational guide to microwave oven operation.

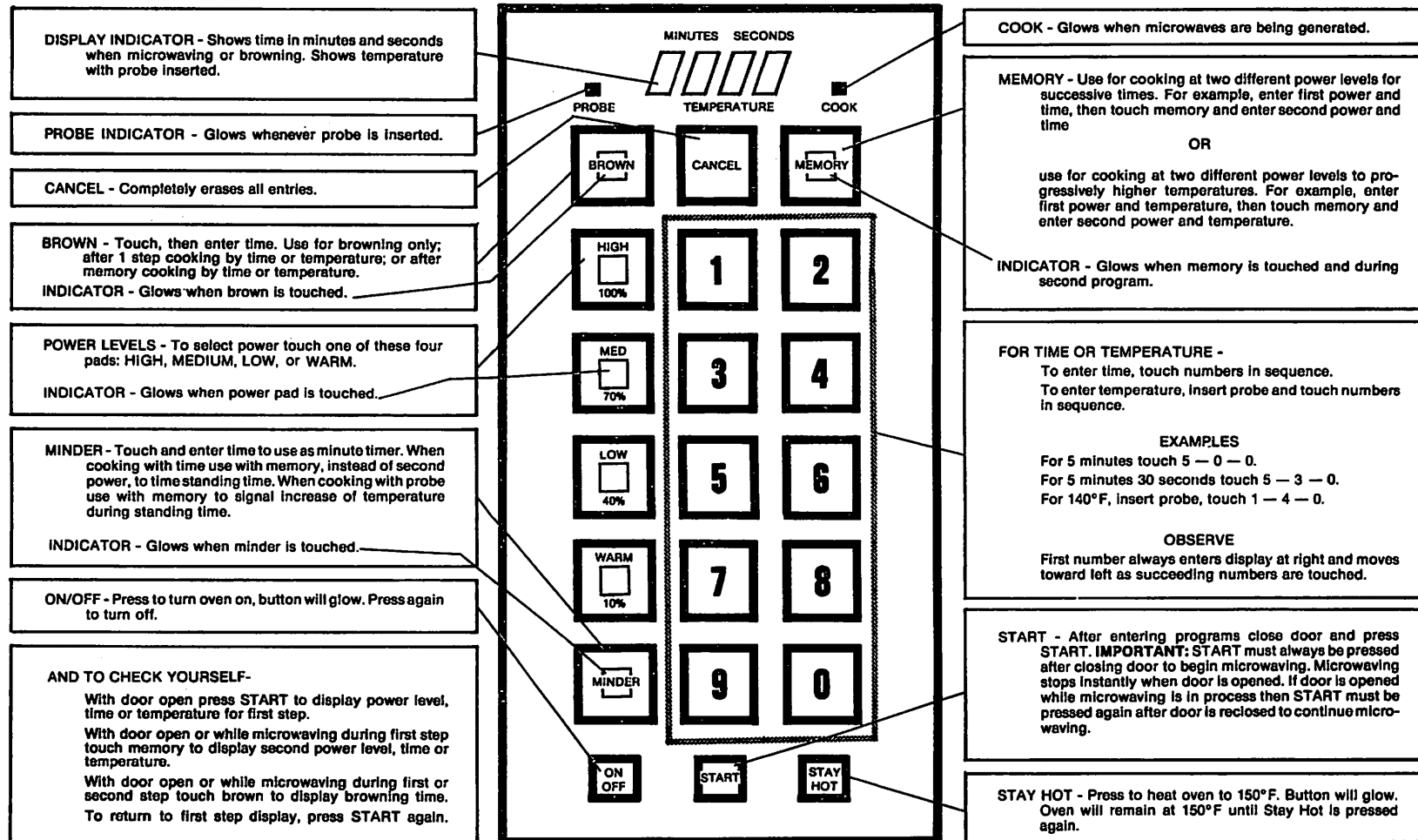

Figure 1. Microwave Oven Operation Guide



REMOTE SPOTLIGHT

Your motorhome is equipped with a remote-controlled high-intensity spotlight which can be operated by three controls located in the lower right corner of the dashboard. The 100,000 BCP (beam candle-power) spotlight, figure 1, is situated on the front left roof section and can be turned on and off, positioned horizontally or vertically at an adjustable rate of speed, and can be used for spot- or flood-lighting purposes.

OPERATION

The following controls operate the spotlight:

SPOT-OFF-FLOOD SWITCH — Selects type of beam desired and controls ON-OFF operation.

SPOTLIGHT AIM CONTROL — Varies the horizontal and vertical positioning of the beam.

SPOTLIGHT SPEED CONTROL — Adjusts the speed of rotation.

LAMP REPLACEMENT

The lamp used in the spotlight is a dual-filament Spot-Flood, type 4710. To replace lamp, loosen the single screw at the bottom of the lamp retain-



Figure 1. Remote Spotlight

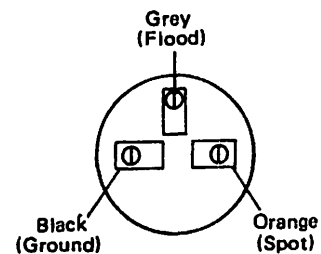

Figure 2. Lamp Replacement

ing ring, remove retaining ring, note color-coding of wire clips to lamps base, figure 2, then exchange with new lamp.



RECIRCULATING TOILET

The recirculating toilet, figure 1, is electrically-operated from the 12-volt dc system and recycles charge water for maximum conservation.

OPERATION

To prepare toilet for use, push dump handle fully into toilet base until handle locks in closed position. With water pump turned on, open refill valve. Watch the sight glass gauge until water level reaches "C" position (approximately 3 gallons), then close refill valve. Raise toilet cover and add the prescribed amount of chemical concentrate directly into the bowl. Depress flush button and release one time to mix chemical. The toilet is now ready for use.

When the content level reaches the "F" marking on the sight gauge, or when sewage odor becomes noticeable, dump toilet wastes into the wastes holding tank by pulling the dump handle fully outward. It may be necessary to slide the carpet out slightly from under the dump handle so that the handle can be depressed enough to free it from the "locked" position. When all liquid has disappeared from the sight gauge, recharge the toilet.

CAUTION

It is of the utmost importance that **NOTHING** other than waste matter and an approved grade of toilet paper be deposited in the recirculating toilet. Almost all malfunctions of the toilet and, particularly, of the waste destruction system (if installed) can be traced to this oversight.

EVACUATION PRIOR TO CONTINUING USE — Proceed as follows:

1. Completely evacuate unit.
2. Pour approximately three gallons of water into the bowl, or until water reaches the charge level indicated as "C" on the sight gauge. Read gauge carefully to avoid over-filling.
3. Add an eight-ounce bottle of Aqua-Kem (or equivalent).

EVACUATION PRIOR TO TEMPORARY STORAGE — Proceed as follows:

1. Completely evacuate unit.
 2. Refill unit to within three inches of bowl top with fresh water.
 3. Add two inches (from the bottle) of bowl cleaner.
 4. Cycle three times.
 5. Let stand for a few minutes for cleaning action.
 6. Evacuate unit again.
 7. The unit is now ready for storage.
- Repeat steps 2 and 3 above to reactivate unit after storage.

MAINTENANCE

The procedures given in table 1 may be used as a general troubleshooting guide.



Figure 1. Recirculating Toilet



Table 1. Recirculating Toilet Troubleshooting Guide

Symptom	Possible Cause	Corrective Action
Toilet wobbles.	Closet bolt nuts loose.	Tighten closet bolt nuts.
	Mounting brackets not seated to floor.	Reposition, if necessary, then tighten closet bolt nuts.
	Closet flange too high; mounting surface uneven.	Check flange height with a straight-edge across flange and measure gap between straight-edge and floor at four leg locations. A height of 1/4 to 7/16 inch is recommended.
Toilet cycles when seat cover is raised.	Actuator button protrudes too far from motor cover.	Alternately press one side of the button, then the other, to work button back further into housing. If button still protrudes too far, replace timer assembly.
Noisy or weak flushing action.	Pump is running backwards (reversed wiring polarity).	Check pump wiring: black wire is positive, white wire is negative (ground).
	Cycling unit without enough charge water.	Add charge water to bring to proper level on sight gauge ("C").
	Pump damaged by continuous dry operation.	Replace pump assembly.
Lack of capacity	Too much charge water.	Use three gallons only to charge unit, filling to "C" on sight gauge.



SCREEN PORCH

The screen porch is designed to be attached to the Zip-Dee awning. Refer to the installation sequence illustration, figure 1, and proceed as follows:

1. Attach coach skirt to coach, figure A.
2. Fill "aqua-bag" of coach skirt with a garden hose, figure B.
3. Assemble 3-piece spring pole, figure C.
4. Insert spring pole into side panel pocket, figure D.
5. Wedge spring pole inside and under front

section of open awning to set panel in place, as shown in figure E.

6. Snap side panel to coach, figure F.
7. Fill side panel "aqua-bag" with water, figure G.
8. Check that side panels are properly positioned, figure H.
9. Insert front panel cable and eye hook through spring pole and elastic. Tighten front and rear knobs for proper tension, figure I.
10. Lock zippers of front and side panels, figure J.
11. Fill front "aqua-bag" to complete installation, figure K.

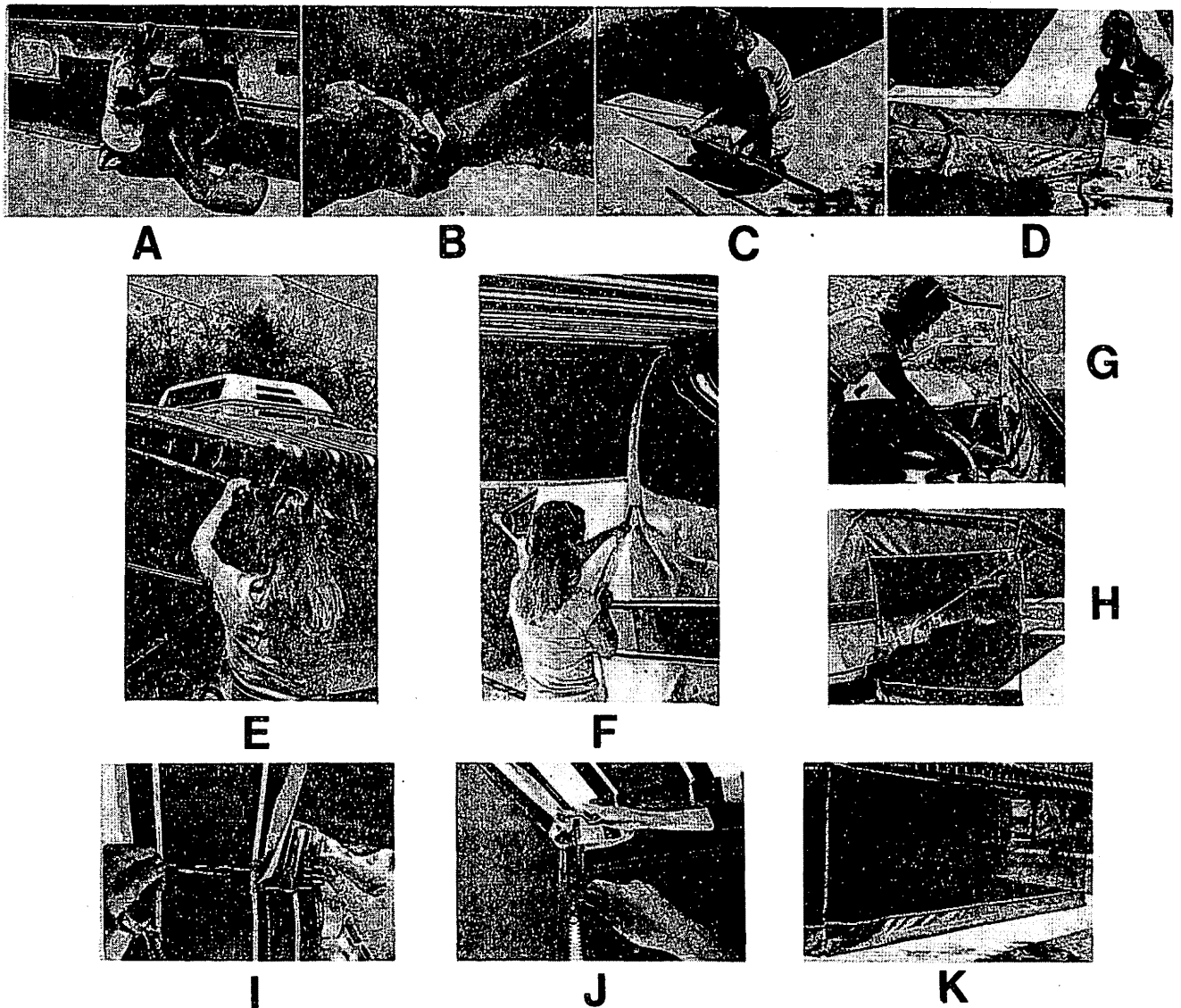

Figure 1. Screen Porch Installation Sequence



SPARE PARTS KIT

To facilitate owner-maintenance of the coach and engine systems, the spare parts kit includes common replacement items which are advisable to have on-hand, as follows:

Item Supplied in Kit	BWL Part No.	Commercial Part No.	Quantity
Fluorescent 12-volt Light Bulbs			2
Bullet Light Bulbs			2
Water Pump Drive Belts	2106771	Dayco 17490; or Gates N9490	2
Alternator Drive Belts	0814038	Dayco 17600; or Gates N9600 (8305X5)	2
Power Steering Drive Belt	0854034	Dayco 17370; or Gates 8394	1
Air Conditioner Drive Belt	0814020	Dayco 17700; or Gates N9700 (8350X5)	1
Fan Drive Belt		Dayco 17430; or Gates N9430 (8346)	1
Oil Filter		Caterpillar 9L-9200	2
Fuel Filter		1P-2299	1
Radiator Hose	2020618	Gates V-F26	2
Radiator Hose	2020626	Gates V-F18	1
Water Pump			1
Water Purifier Element			1
Engine Oil (Quarts)			2
Transmission Fluid (Quarts)			1
Air-operated Grease Gun			1



WASTE DESTRUCTION SYSTEM

The Thermasan waste destruction system uses the intense heat from the engine exhaust to disintegrate holding tank wastes into a harmless and invisible emission.

The system operates as follows: A chemical and biochemical reaction is first created in the holding tank. The prepared waste is then pumped via a metered injection into the Sanijector, which is used to screen and spray the material into the engine exhaust system. All waste and bacteria are destroyed within the super-hot exhaust and the remaining gaseous by-products combine with the exhaust gases.

The system used in the coach is specifically designed for operation with both holding tanks: gray water and waste. It will dispose of approximately one gallon of waste for every 15 miles of driving (depending on driving conditions). Two pumps are used, each pumping waste from a holding tank into a combination hose connection on the outlet side of the pumps, where the contents are mixed and pumped into the exhaust. Operation is covered in the following paragraphs.

OPERATION

The system is operated from the control panel, figure 1, as follows:

1. Set OFF-ON DIM control to ON and adjust lighting level of READY (green) and REACTION (red) indicators; EMPTY (white) indicator brightness level is fixed. Light functions are:
 - a. GREEN light on indicates that the system is ready.
 - b. RED light on indicates that the system is operating. It will light when driving at a steady speed above 35 mph, and when going uphill. The light (and the system) turns off when traveling at less than 30 to 35 mph or going downhill. Red light will blink when switch is pulled out to check pump operation.
 - c. WHITE light on indicates that liquid level is below evacuation probe; light off, indicates that level is above evacuation probe.

This light will flicker when the level nears the probe, at which time the system can be shut off. (It may also flicker when driving on rough roads.)

2. It is advisable to operate the system whenever there is waste in the tank. When waste is below probe level, the system will pump air, without any damage to the pump.

3. Avoid depositing napkins, kleenex or other wet-strength articles, or combustible materials, into the holding tank.

Occasional draining of the holding tanks is advisable to remove foreign particles and insoluble matter that could damage the system. Inspect hoses and evacuation probe and clean, if necessary, while tank is empty.

For winter storage, holding tanks should be dumped and hoses flushed out with an approved anti-freeze, leaving some solution in the hoses.

If exhaust system odors are detected, dilute contents of holding tanks with water, or add a solution of Aqua Kem (or equivalent).

User maintenance, other than that previously described, is not recommended.

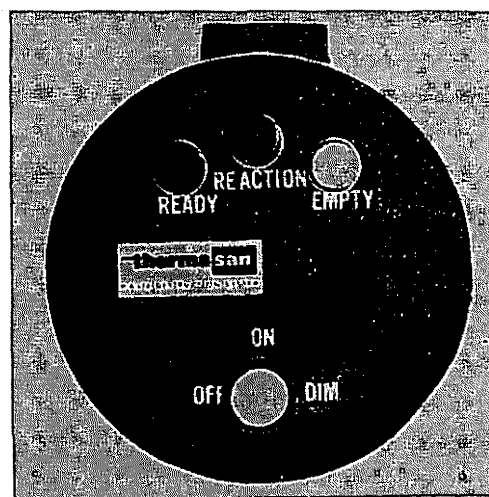

Figure 1. Waste Destruction System, Control Panel

